

SEIKO

QUARTZ

Cal. 93A

**PARTS
CATALOGUE**

Cal. 93A



113 950



☆221 951



231 950



241 950



261 950



☆271 950



281 950



282 950



☆354 950



383 950



384 950



386 950



604 950



766 950



4001 951



4002 950



4146 950



4216 950

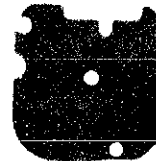

4216 983



4219 950



4239 950



4242 950

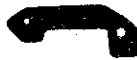

4259 950



4270 950



4446 950



☆Maxell SR916SW

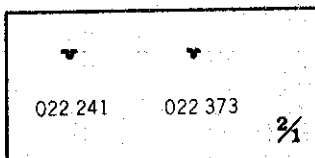

022 241

022 373

3/1

Cal. 93A

Characteristics

Casing diameter : ϕ 24.0 mm
 Maximum height : 1.5 mm without battery
 Jewels : 8 j
 Frequency of quartz crystal oscillator : 32,768 Hz (Hz=Hertz Cycles per second)
 Driving system : Step motor system (2 poles)
 Regulation system : Rotary step switch type

PART NO.	PART NAME	PART NO.	PART NAME
113 950	Train wheel bridge	027 877	Tube for setting wheel plate complete
☆221 951	Center wheel & pinion (1.6 mm)		screw
☆221 954	Center wheel & pinion (2.3 mm)	☆Maxell SR916SW	Silver oxide battery
☆221 956	Center wheel & pinion (1.8 mm)		
231 950	Third wheel & pinion		
241 950	Fourth wheel & pinion		
261 950	Minute wheel		
☆271 950	Hour wheel (0.9 mm)		
☆271 953	Hour wheel (1.6 mm)		
☆271 955	Hour wheel (1.1 mm)		
281 950	Setting wheel		
282 950	Clutch wheel		
☆354 950	Winding stem		
☆354 951			
383 950	Setting lever		
384 950	Yoke (Clutch lever)		
386 950	Setting lever spring		
604 950	Setting wheel plate complete		
766 950	Intermediate minute wheel		
4001 951	Circuit block		
4002 950	Coil block		
4146 950	Step rotor		
4216 950	Insulator for battery		
4216 783	Insulator		
4219 950	Battery connection insulator		
4239 950	Rotor stator		
4242 950	Battery connection (+)		
4259 950	Anti-magnetic shield plate		
4270 950	Battery connection (-)		
4446 950	Crystal unit cushion		
011 552	Upper hole jewel for third wheel		
011 552	Lower hole jewel for third wheel		
011 552	Upper hole jewel for fourth wheel		
011 552	Lower hole jewel for fourth wheel		
011 552	Upper hole jewel for step rotor		
011 552	Lower hole jewel for step rotor		
011 552	Upper hole jewel for minute wheel		
011 552	Lower hole jewel for minute wheel		
022 241	Anti-magnetic shield plate screw		
022 373	Train wheel bridge screw		
022 373	Setting wheel plate complete screw		
022 373	Circuit block screw		
023 343	Battery connection (+) pin		
027 059	Tube for circuit block		
027 839	Rotor stator fixing pin		
027 877	Tube for train wheel bridge		





☆⇨ Please see remarks on the reverse page.
 Part numbers in light letters are not shown in photos.

Cal. 93A

Remarks :

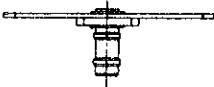
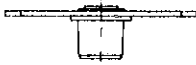
Center wheel & pinion, Hour wheel

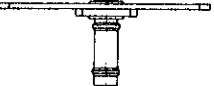
There are three kinds of Dial, Hour wheel, and Center wheel & pinion as specified below. Further, it can be distinguished between the dial designed for thick models and the dial designed for thin models whether it has a printing on the reverse side of the dial or not. (On the reverse side of the dial designed for thick models, "30" is printed near the center of it however the one for thin models there is no printing on it.)
Combination:

Type	Center wheel & pinion	Hour wheel
a. (Dials for thin type models)	 ☆221 951	 ☆271 950
b. (Dials for thick type models,	 ☆221 956	 ☆271 955
c. (Dials with index jewels)	 ☆221 954	 ☆271 953

Winding stem

☆354 950 } Refer to the photograph on the front page. If the combination of the winding stem
 ☆354 951 } and case is unknown, check the case number and refer to "SEIKO Quartz Casing
Parts List" to choose a corresponding winding stem.

Battery

☆Maxell SR916SW.....The applied battery for this calibre might be added the substitutive in the future.
 In that case, please refer to separate "**BATTERIES FOR SEIKO QUARTZ
 WATCHES**".

TECHNICAL GUIDE

SEIKO
QUARTZ

CAL. 93A

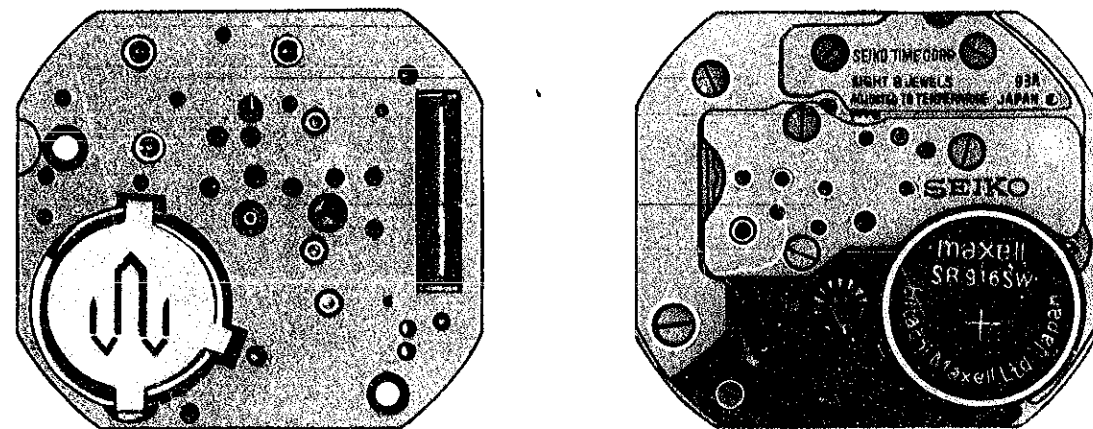

CONTENTS

I. SPECIFICATIONS	1
II. STRUCTURE OF CIRCUIT BLOCK	1
III. DISASSEMBLING, REASSEMBLING AND LUBRICATING	2
IV. CHECKING AND ADJUSTMENT	4
• CHECK OUTPUT SIGNAL	4
• CHECK HAND SETTING CONDITION	4
• CHECK BATTERY VOLTAGE	4
• CHECK CIRCUIT BLOCK CONDUCTIVITY	4
• CHECK COIL BLOCK	4
• CHECK GEAR TRAIN MECHANISM	4
• CHECK ACCURACY	4
• CHECK CURRENT CONSUMPTION	4
• CHECK APPEARANCE AND FUNCTIONING	4

I. SPECIFICATIONS

Item	Cal. No.	93A
Time indication		Two-hand time indication (The hand moves every 20 seconds.)
Loss/gain		Loss/gain at normal temperature range Monthly rate: less than 15 seconds (Annual rate: less than 3 minutes)
Movement size		φ24.6 mm (20 mm between 3 o'clock and 9 o'clock sides) (22 mm between 12 o'clock and 6 o'clock sides)
Casing diameter		φ24.0 mm (20 mm between 3 o'clock and 9 o'clock sides) (22 mm between 12 o'clock and 6 o'clock sides)
Height		1.5 mm (1.6 mm with battery)
Regulation system		Rotary step switch
Measuring gate by Quartz Tester		The gate of 10 seconds is available.
Battery		Maxell SR916SW Battery life is approximately 2 years. Voltage: 1.55V
Jewels		8 jewels

II. STRUCTURE OF CIRCUIT BLOCK

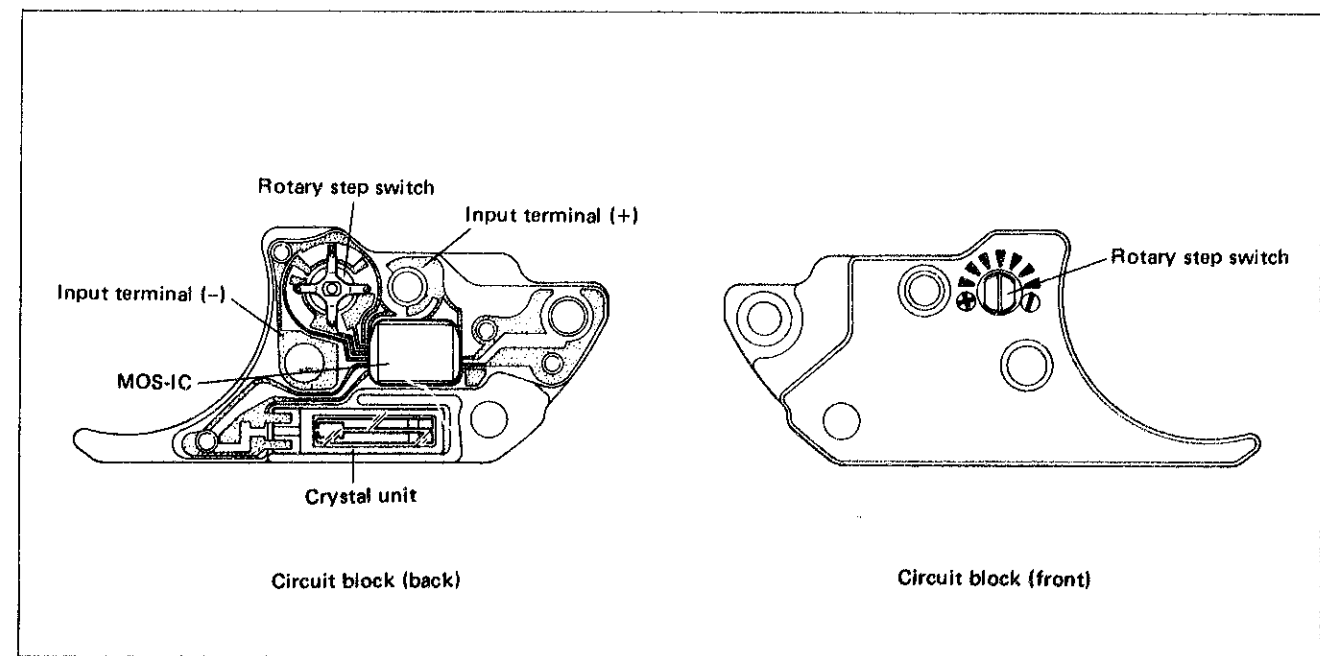



III. DISASSEMBLING, REASSEMBLING AND LUBRICATING

Disassembling procedures: ① → ⑳

Reassembling procedures: ㉓ → ①

(1) Disassembling and reassembling of ① Minute hand ~ ⑤ Case ring

The following types of screws are used.

Shape	Parts No.	Name
	022 373	Train wheel bridge screw (3 pcs.) Setting wheel plate complete screw (2 pcs.) Circuit block screw (2 pcs.)
	022 241	Anti-magnetic shield plate screw (2 pcs.)

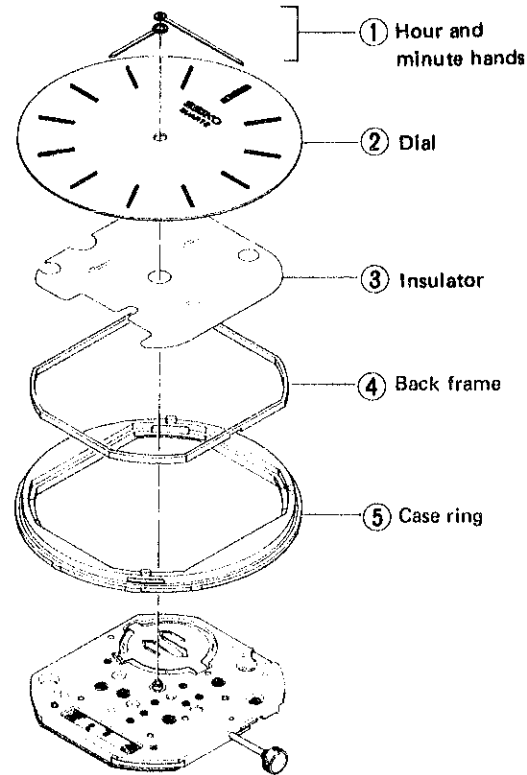

(2) Disassembling and reassembling of ⑥ Anti-magnetic shield plate screw ~ ⑪ Coil block

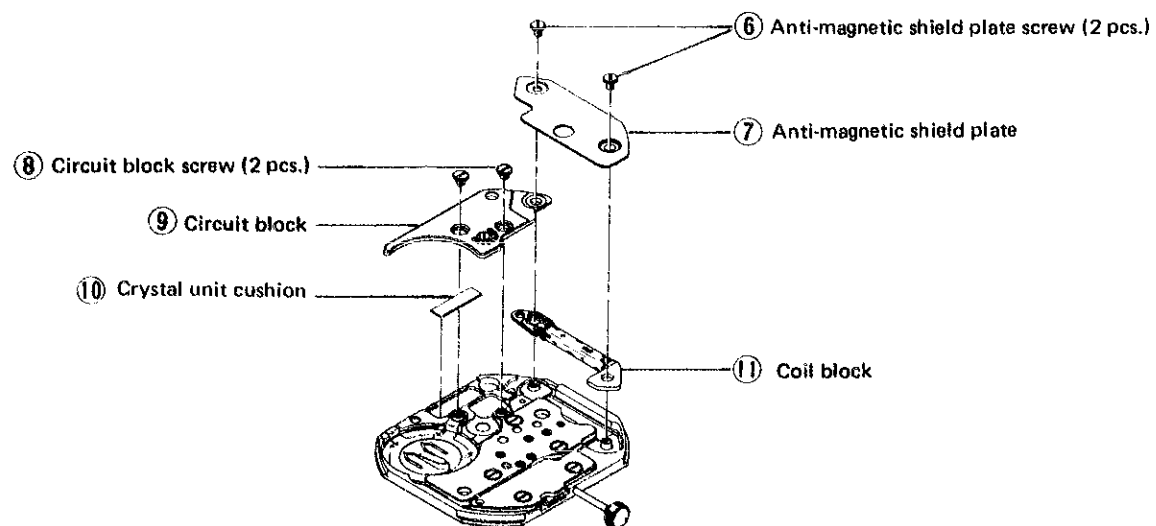

(3) Disassembling, reassembling and lubricating of ⑫ Train wheel bridge screw ~ ㉓ Clutch wheel

• Lubricating

Types of oil

 Moebius A

 SEIKO Watch Oil S-6

Oil quantity

 Normal quantity

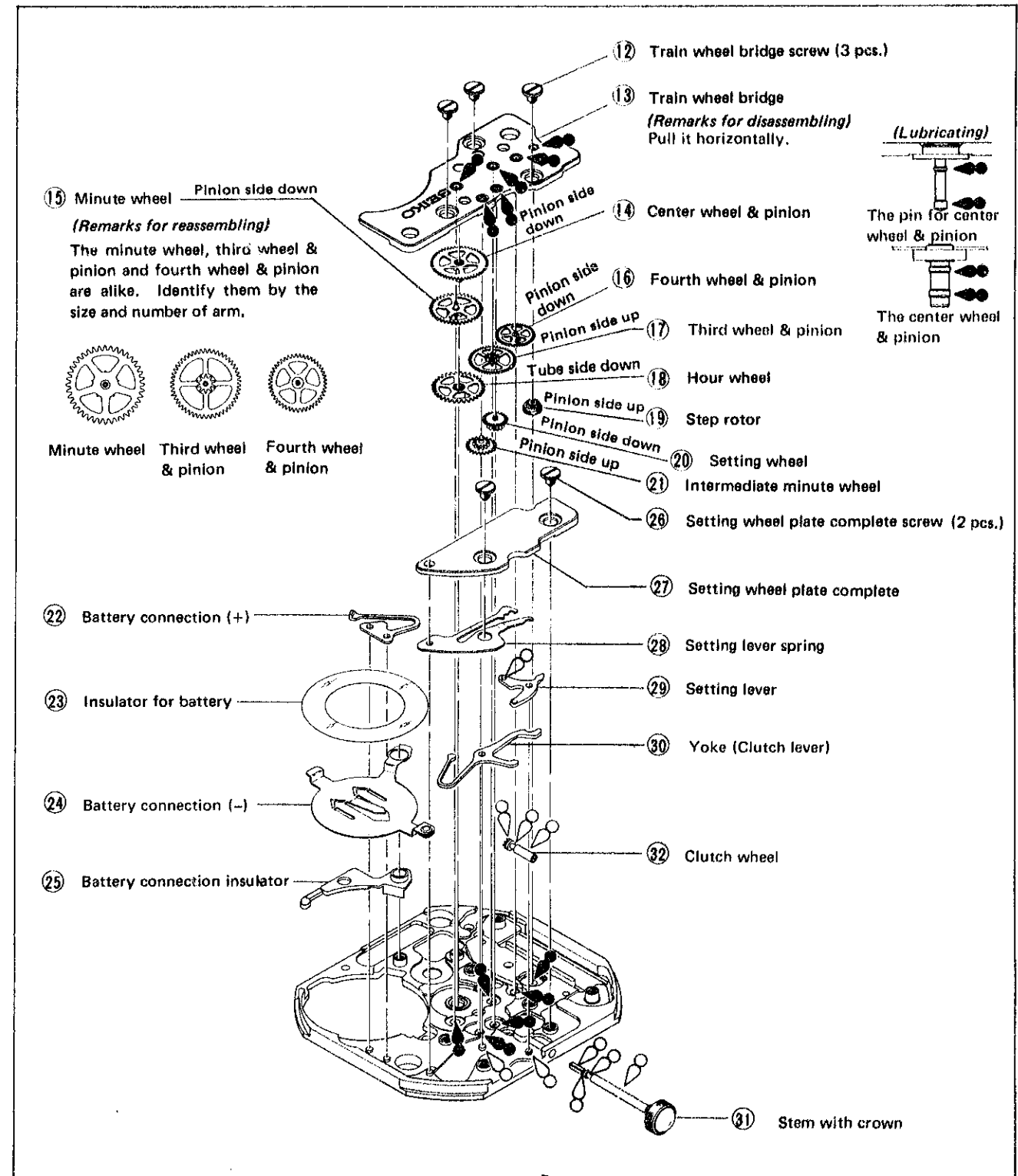

IV. CHECKING AND ADJUSTMENT

- Refer to the "SEIKO QUARTZ TECHNICAL GUIDE, GENERAL INSTRUCTION for ANALOGUE WATCHES" for details.

Procedure
<p>CHECK OUTPUT SIGNAL</p> <p>If it flashes 5 seconds, 5 seconds, 10 seconds and 5 seconds, 5 seconds, 10 secondsNormal When it does not flash at the above intervalsDefective</p>
<p>CHECK HAND SETTING CONDITION</p>
<p>CHECK BATTERY VOLTAGE</p> <p>More than 1.5VNormal Less than 1.5VDefective</p>
<p>CHECK CIRCUIT BLOCK CONDUCTIVITY</p>
<p>CHECK COIL BLOCK</p> <p>Required value: 1.5KΩ ~ 3.5KΩNormal Less than 1.5KΩ }Defective More than 3.5KΩ }</p>
<p>CHECK GEAR TRAIN MECHANISM</p>
<p>CHECK ACCURACY</p> <p>Refer to the Technical Guide of Cal. 2320A (page 2), "Time accuracy adjusting".</p>
<p>CHECK CURRENT CONSUMPTION</p> <p>The second hand moves every 20 seconds. Be sure to measure the current consumption for 3 minutes or so in order to obtain a stable value. Measure the current consumption while the hand is moving and while it is not moving, and take the average which must be compared with the value specified below.</p> <p>Required value: Less than 0.8μANormal More than 0.8μADefective</p>
<p>CHECK APPEARANCE AND FUNCTIONING</p>

All procedures of Disassembling, Reassembling, Checking and Adjustment are completed.