

SEIKO

QUARTZ

**3003
(Cal.0843A)**

PARTS LIST

Calibre No. 0843A	Jewels 9j	Style Name QUARTZ 3003
-----------------------------	---------------------	----------------------------------

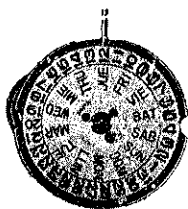

Characteristics

Casing diameter : ϕ 24.0 mm
 Maximum height : 4.8 mm
 Frequency of quartz crystal oscillator : 32,768 Hz
 (Hz=Hertz Cycles per second)
 Driving system : Step motor system
 Regulation system : Trimmer condenser
 Second-setting device
 Calendar (day & date)
 Instant setting device for day & date calendar
 Bilingual change-over system for day of week

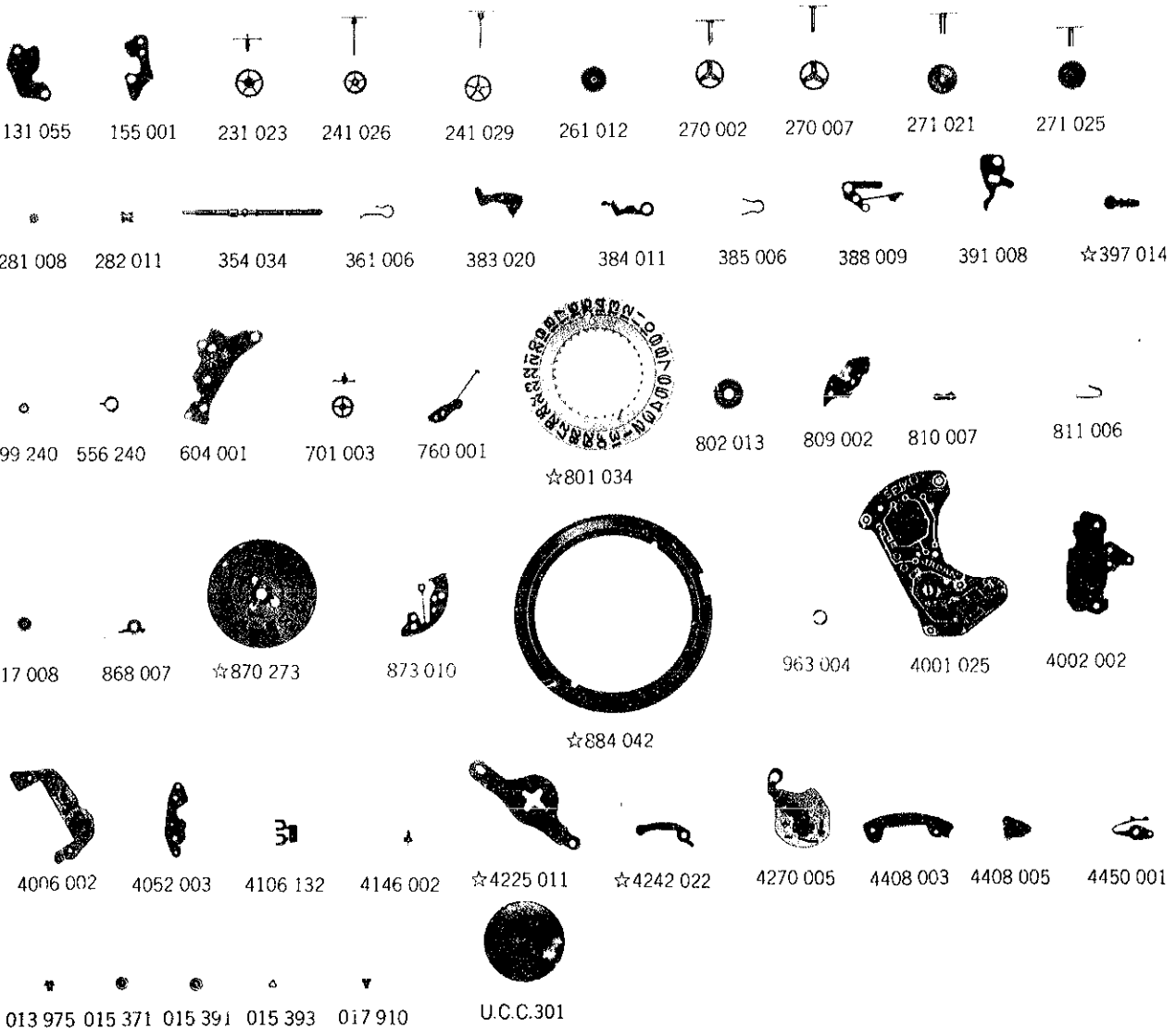

012 287	012 377	012 378	012 379	012 380	012 382	012 383	012 384	012 385	012 386	012 387	012 399
012 694	012 696	012 736	012 767								

☆⇨ Please see remarks on the next reverse page.

Calibre No.		Jewels	Style Name	
0843A		9j	QUARTZ 3003	
PART NO.	PART NAME	PART NO.	PART NAME	
131 055	Third wheel bridge	011 527	Upper hole jewel for fifth wheel	
155 001	Lower cock for fifth wheel	011 527	Lower hole jewel for fifth wheel	
231 023	Third wheel & pinion	011 527	Lower hole jewel for third wheel	
241 026	Fourth wheel & pinion (5.89mm)	011 537	Upper hole jewel for third wheel	
241 029	Fourth wheel & pinion (6.59mm)	011 537	Upper hole jewel for fourth wheel	
261 012	Minute wheel	012 287	Second jumper screw	
270 002	Center minute wheel (3.59mm)	012 377	Coil block screw	
270 007	Center minute wheel (4.29mm)	012 378	Rotor stator screw	
271 021	Hour wheel (2.72mm)	012 379	Third wheel bridge screw	
271 025	Hour wheel (3.42mm)	012 380	Lead terminal screw	
281 008	Setting wheel	012 380	Temperature compensation condenser screw	
281 008	Setting wheel for calendar correction		012 382 Second-setting lever screw	
282 011	Clutch wheel		012 383 Setting wheel plate complete screw	
354 034	Winding stem		012 384 Yoke spring holder screw	
361 006	Second-setting lever spring		012 385 Lower cock screw for fifth wheel	
383 020	Setting lever		012 386 Case screw	
384 011	Yoke (Clutch lever)		012 387 Screw for holding spring for battery (A)	
385 006	Yoke spring (Clutch lever spring)		012 387 Plus terminal screw of battery connection	
388 009	Yoke spring holder		012 399 Screw for holding spring for battery (B)	
391 008	Second-setting lever		012 694 Circuit block screw (A)	
☆397 014	Lever for unlocking stem		012 696 Circuit block screw (B)	
499 240	Day finger ring		012 736 Date jumper guard screw	
556 240	Date finger		012 736 Day jumper screw	
604 001	Setting wheel plate complete		012 767 Date driving wheel screw	
701 003	Fifth wheel & pinion		013 975 Eccentric dial pin	
760 001	Second jumper		015 371 Diafix upper hole jewel with frame for rotor	
☆801 034	Date dial		015 391 Diafix lower hole jewel with frame for rotor	
802 013	Date driving wheel		015 393 Diafix upper spring for step rotor	
809 002	Date jumper guard		015 393 Diafix lower spring for step rotor	
810 007	Date jumper		017 016 Lower bridge tube for step rotor	
811 006	Date jumper spring		017 017 Tube for yoke (Tube for clutch lever)	
817 008	Intermediate date wheel		☆017 018 Tube for circuit block (A, D)	
868 007	Day finger		017 019 Switch pin	
☆870 273	Day star with dial disk (English-Spanish)		☆017 020 Tube for circuit block (B)	
☆870 274	Day star with dial disk (English-French)		017 021 Tube for third wheel bridge screw	
☆870 275	Day star with dial disk (English-German)		☆017 022 Tube for circuit block (C)	
☆870 276	Day star with dial disk (English-Italian)		017 027 Second-setting lever pin	
☆870 277	Day star with dial disk (English-Chinese)		017 028 Lower cock tube for fifth wheel	
☆870 278	Day star with dial disk (English-Portuguese)		☆017 082 Tube for circuit block (D)	
873 010	Day jumper		017 910 Holding pin for second-setting lever	
☆884 042	Holding ring for dial		U.C.C.301 } Silver oxide battery	
963 004	Snap for day star with dial disk		Maxell SR43SW }	
4001 025	Circuit block			
4002 002	Coil block			
4006 002	Motor block			
4052 003	Upper plate for step rotor			
4106 132	Temperature compensation condenser			
4146 002	Step rotor			
☆4225 011	Holding spring for battery			
☆4242 022	Plus terminal of battery connection			
4270 005	Battery connection			
4408 003	Insulator			
4408 005	Insulating spacer for circuit block			
4450 001	Switch lever			
011 221	Diafix upper cap jewel for step rotor			
011 221	Diafix lower cap jewel for step rotor			

☆⇔ Please see remarks on the reverse page.
Part numbers in light letters are not shown in photos.

Calibre No.

0843A

Jewels

9j

Style Name

QUARTZ 3003

Remarks :

Lever for unlocking stem

☆397 014.....Used for the one-piece or square type water-resistant case. Adjust the length of the unlocking stem lever by cutting the tail on the position marked arrow, which should be exposed on the case face, as shown in the illustration.

Movement in the case dial upside

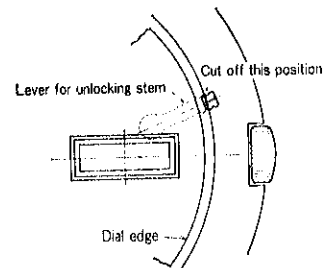

Date dial

☆801 034.....Used when both the crown and the calendar frame are located at 3 o'clock position. If any other type of date dial is required, specify ① Cal. No. ② the crown position ③ the date frame position and ④ Dial No.

Day star with dial disk

☆870 273~278.....Used when both the crown and the calendar frame are located at 3 o'clock position. If any other type of day star with dial disk is required, specify the number printed on the disk.

Holding ring for dial

☆884 042.....Used except for one-piece type case. The type of a holding ring for dial to be used is determined based on the design of cases and dials. Check the case number and refer to "SEIKO Quartz Watch Casing Parts List" to choose an appropriate holding ring for dial. Specify the part number of the holding ring for dial assigned on the above parts list when you place the order.

Holding spring for battery

☆42 25 011.....Used only for case without battery hatch.

Plus terminal of battery connection

☆4242 022.....Used only for case with battery hatch.

Tube for circuit block (A, B, C, D)

- ☆017 018(A,D)
☆017 020(B)
☆017 022(C)
☆017 082(D)

There are available four types of Tube for circuit block. They are used as illustrated on the right. Tube for circuit block (D) is also subclassified into two types; 017 018 and 017 082. For the replacement of Tube for circuit block (D), select a proper part as instructed below.
○ Where the main plate for the tube (D) has a through hole: 017 018
○ Where the main plate for the tube (D) has no through hole: 017 082

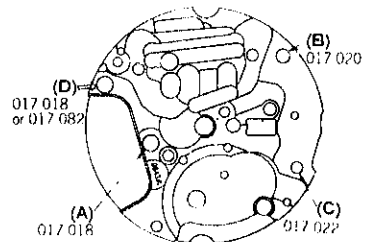

Battery

☆U.C.C. 301.....The applied battery for this calibre might be added the substitutive in the future. In that case, please refer to separate "BATTERIES FOR SEIKO QUARTZ WATCHES".

TECHNICAL GUIDE

SEIKO
QUARTZ

CAL.0843A



CONTENTS

SPECIFICATIONS AND FEATURES	1
1. Specifications	1
2. Features	1
3. Movement structure	2
4. Outline of functioning	3
5. Case	3
6. Hand setting and calendar setting	4
7. After-servicing instruments and materials	5
DISASSEMBLING, REASSEMBLING, LUBRICATING AND CLEANING	6
1. Calendar mechanism	6
2. Electronic circuit mechanism	8
3. Gear train mechanism	10
4. Setting mechanism	12
5. Motor block	14
6. Cleaning	15
CHECKING AND ADJUSTMENT	17
1. Guide for Checking and Adjustment	17
2. Procedures for Checking and Adjustment	18
A. Check output signal	18
B. Check battery voltage	18
C. Check reset switch	18
D. Check battery conductivity	20
E. Check circuit block conductivity	20
F. Check coil block	22
G. Check output signal	22
H. Check second jumper	22
I. Check for short circuit of battery connection	24
J. Check accuracy	26
* Time accuracy adjusting method	26
* Measuring current consumption	26

SEIKO Quartz Calibre 0843A

The SEIKO Quartz Cal. 0843A is a thin and compact crystal oscillator watch providing easy after-servicing, that has been made possible through SEIKO's advanced manufacturing techniques and the possible complete electronic system available today.

Calibre 0843A

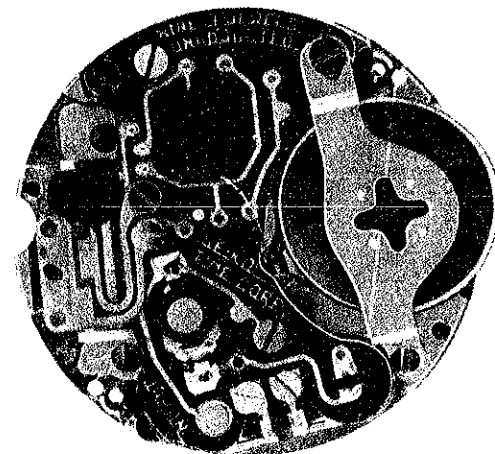

Movement

SPECIFICATIONS AND FEATURES

1. Specifications

Item	Calibre	Cal. 0843A
Additional mechanism		Calendar (day & date) Bilingual change-over system for the day of the week Instant day and date setting Second setting device Electronic circuit reset switch
Crystal oscillator		32,768 Hz (Hz = Hertz . . . cycles per second)
Loss/gain		Loss/gain at normal temperature Monthly rate: less than 10 seconds (Annual rate: less than 2 minutes)
Casing diameter		φ 24.0 mm
Height		4.84 mm
Operational temperature range		-10°C ~ +60°C (14°F ~ 140°F)
Driving system		Step motor system (bipolar)
Regulation system		Trimmer condenser
Battery power		Battery life is over one year Silver oxide battery (U.C.C. 301) Voltage 1.5 V Capacity 100mAH Size φ 11.6mm X 4.2mm
Jewel		9 jewels

2. Features

- (1) The crystal oscillator is the ultrasonic tuning fork type and generates a stabilized oscillation of 32,768 Hz.
- (2) One-second hand operation by the step motor system with high stability and durability.
- (3) Second setting device
The second hand stops precisely on every second mark.
- (4) The movement consists of the mechanical portion (gear train), electronic circuit block and motor block. These enable easy checking and adjustment.
- (5) The bilingual change-over system for the day of the week, and instant day and date setting device.
- (6) The compact movement (casing diameter—φ 24.00 mm) makes a smartly designed watch possible.
- (7) A battery life is over one year.

3. Movement structure

The circular movement consists of the circuit block, motor block, coil block, the battery and the mechanical portion of which the main component is a gear train. Since each portion is a separate unit, easy checking and adjustment is possible.

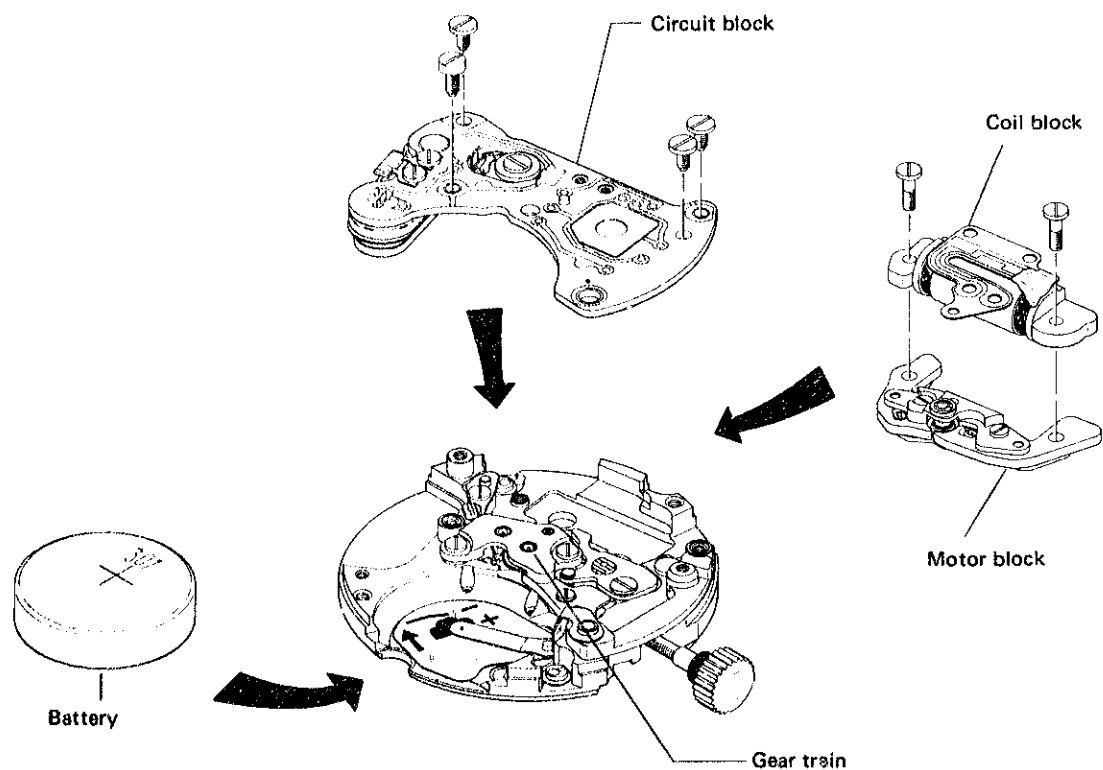
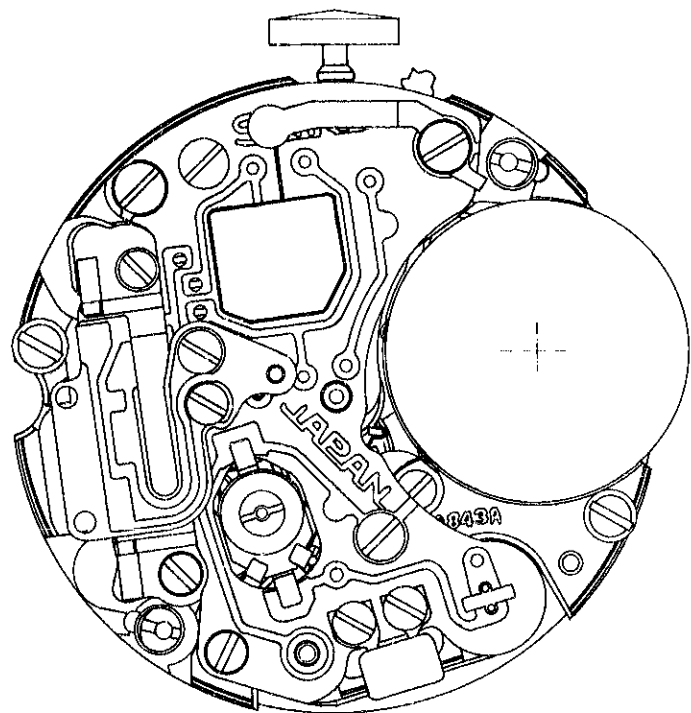

4. Outline of functioning

- (1) The crystal oscillator by supplying voltage oscillates accurately at 32,768 Hz.
- (2) The electronic circuit receives the 32,768 Hz oscillations (electric signals) and converts them into impulses at the rate of one per second, i.e. 1/2 (16,384 Hz), 1/2 (8,192 Hz) . . .
- (3) The one-per-second signals are transmitted to the coil block, causing the step motor to rotate once every second in 180° increments.

- (4) This rotation is transmitted to the gear train thus moving the hands.

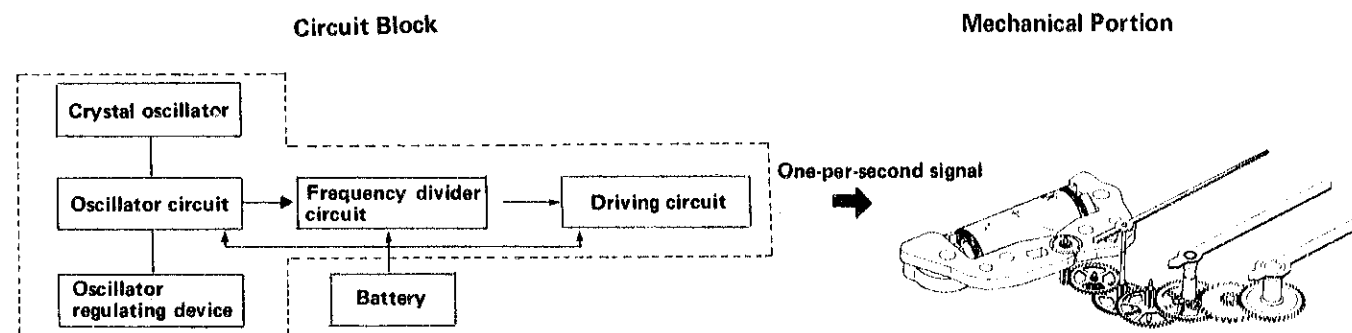
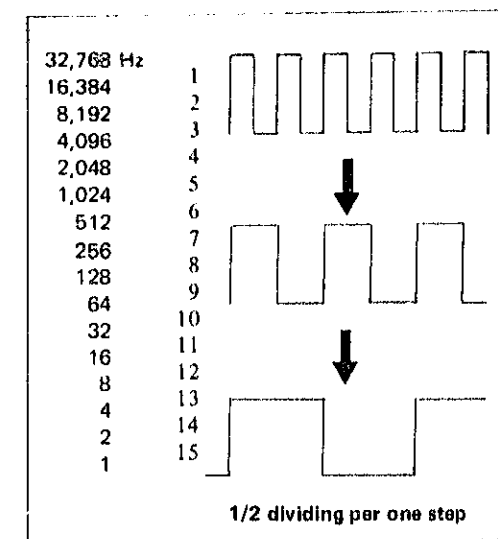

5. Case

- **Anti-magnetic construction**

The SEIKO Quartz case is made of special anti-magnetic metal which completely shields the watch from external magnetic fields.

- **Current flow**

The current flows from the battery through a case to the movement.

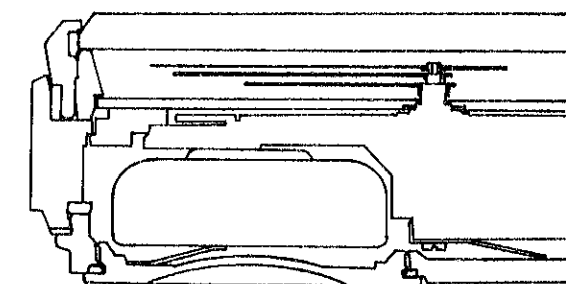

6. Hand setting and calendar setting

Date and day changes as follows:

- Date 00:00 (22:30 ~ 24:00)
- Day 2:55 (0:30 ~ 2:55)

Crown position

- Normal position . . . Free
- First click . . .
Change of day and date
Date change . . . counterclockwise
Day change . . . clockwise
- Second click . . . Hand setting, reset switch and second setting

(1) Hand setting

Pull out the crown to the second click and the second hand stops precisely on the second mark.

Procedures

- (1) Pull the crown out to the second click.
- (2) Turn the crown and set the time of the hour hand and the minute hand.
 - First turn the hands past the 12:00 o'clock position to see if the day changes, then set the time correctly.
 - As the torque of the gear train is transmitted reversly, the time is set accurately by turning the hands between 5 and 10 minutes ahead and then turning it back to the desired time.

- (3) To synchronize with a time signal, push the crown in.

Push the crown in to the innermost position to start the watch. Then the hour, minute and second hand can be set exactly.

(2) Calendar setting

Pull the crown out to the first click.

- (1) Turn the crown counterclockwise and the date will change.

- (2) Turn the crown clockwise and the day of the week will change.

Select the desired language as two languages appear alternately when setting the day of the week.

If the setting of the calendar is made when the hour hand is pointing to the time between 9:00 p.m. and 3:00 a.m., sometimes the calendar will not change the next day. Please reset the calendar before or after this time period.

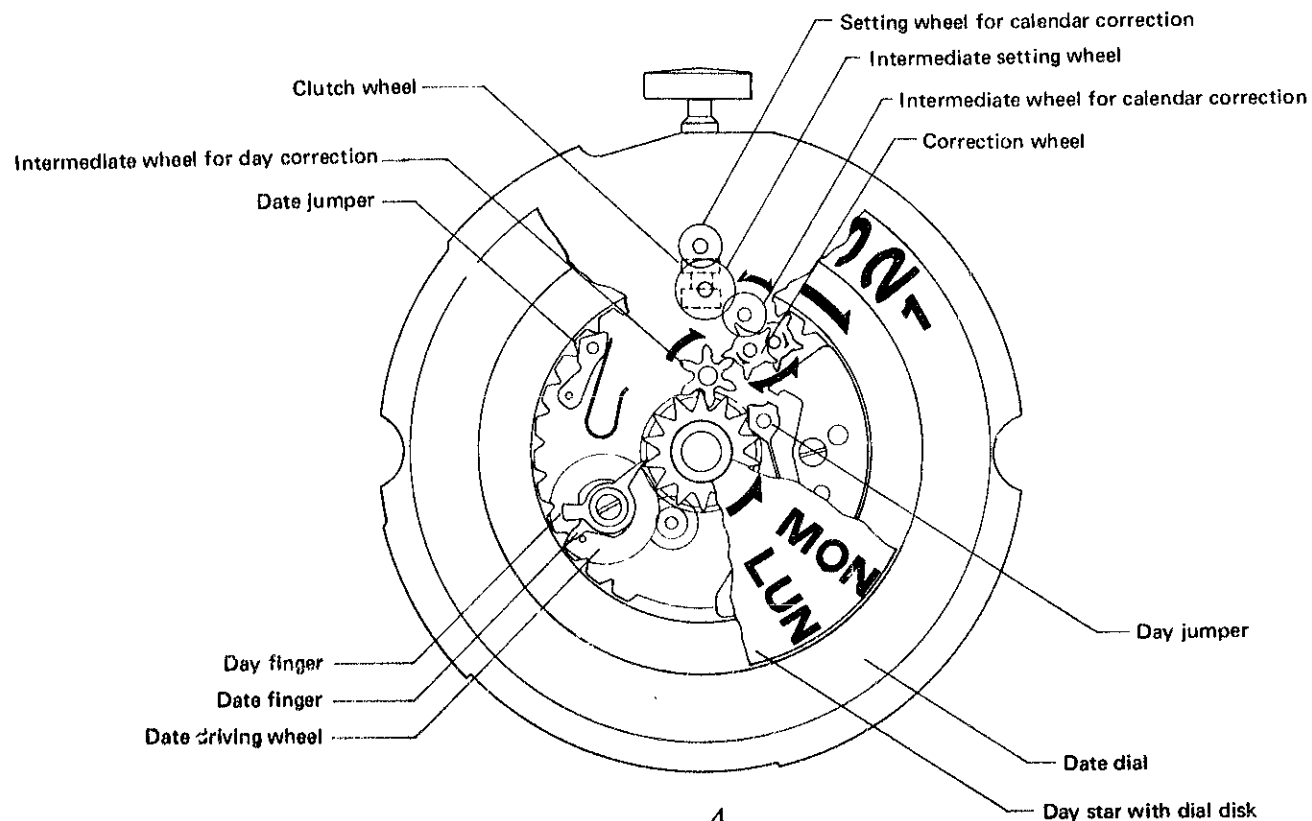
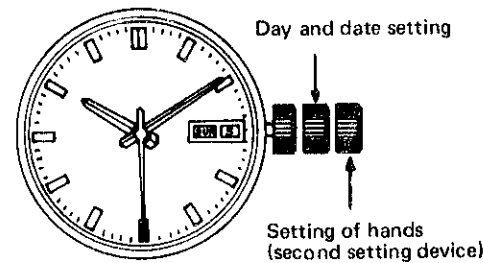

7. After-servicing instruments and materials

For after-servicing of the SEIKO Quartz watch, the following after-servicing instruments and materials are necessary.

1. Quartz Tester

Used to check time accuracy and the flow of current from the circuit block to the coil block.

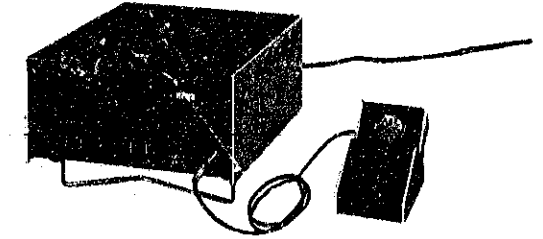

2. Tester

Used for checking battery voltage, measuring resistance and testing conductivity.



3. Movement holder

Used for disassembling and reassembling the movement.

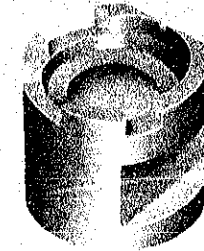

4. Holding spring for battery

Used for securing the battery when the movement is removed from the case or when the case back is removed.

5. Others

- (1) Anti-magnetic tweezers for handling the magnetized step rotor, etc.
- (2) Nonmetallic tweezers for handling the battery.

Disassembling procedures Fig.: ① ~ ⑤⑦

Reassembling procedures Fig.: ⑤⑦ ~ ①

1. Calendar mechanism

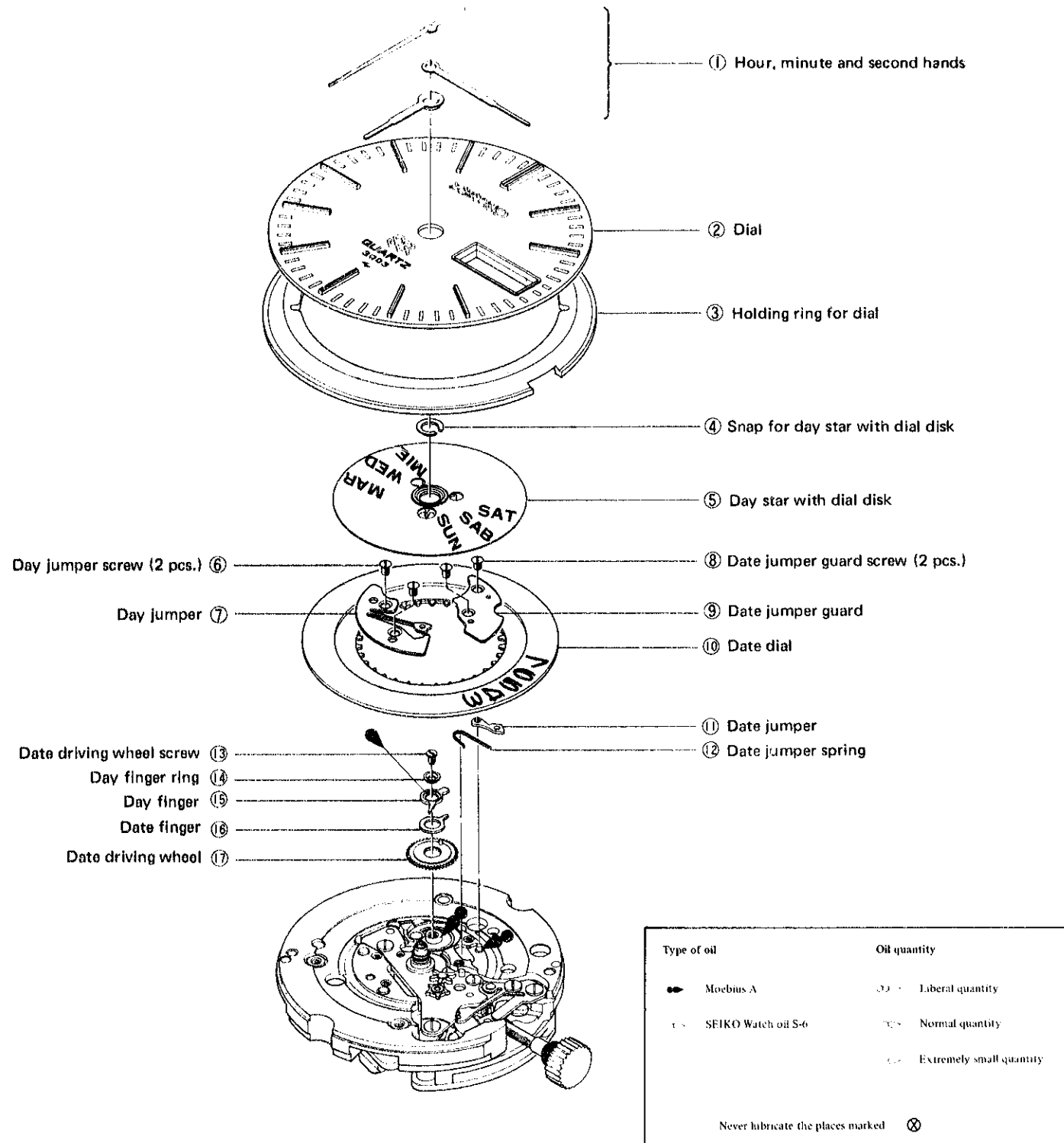

REMARKS:

As for the watch with a battery hatch, first remove the battery and the movement.

How to remove the hands and the dial

Removing and mounting the hands ①

Remove and mount the hands after pulling the crown out to the second click.

Removing and replacing the dial ②

After turning the eccentric dial pin between 90° and 150° in the arrow marked direction removing and replacing the dial is possible.

When replacing the dial, tighten the eccentric dial pin according to the figures shown in the following diagram.

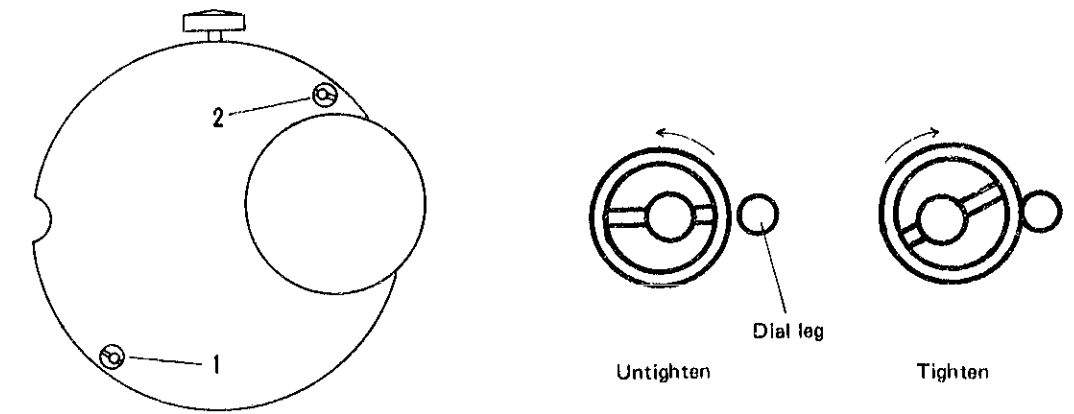

How to remove the snap for the day star with dial disk ④

Put the tip of a screw driver between the two ends of the snap for day star with dial disk and pull the screw driver up to remove the snap for day star with dial disk.

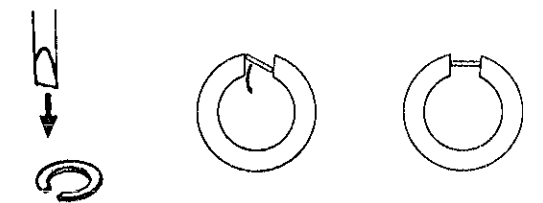

How to fix the date finger and the day finger ⑬ ⑭ ⑮ ⑯

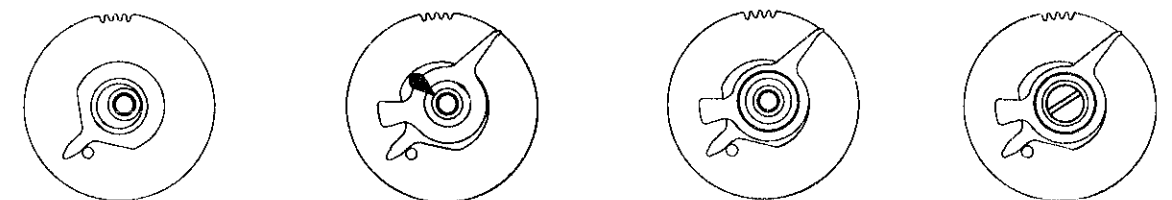

1. Place the date finger as shown in the above diagram.

2. Put on the day finger and lubricate it a little.

3. Now put on the day finger ring.

4. Tighten the date driving wheel screw.

2. Electronic circuit mechanism

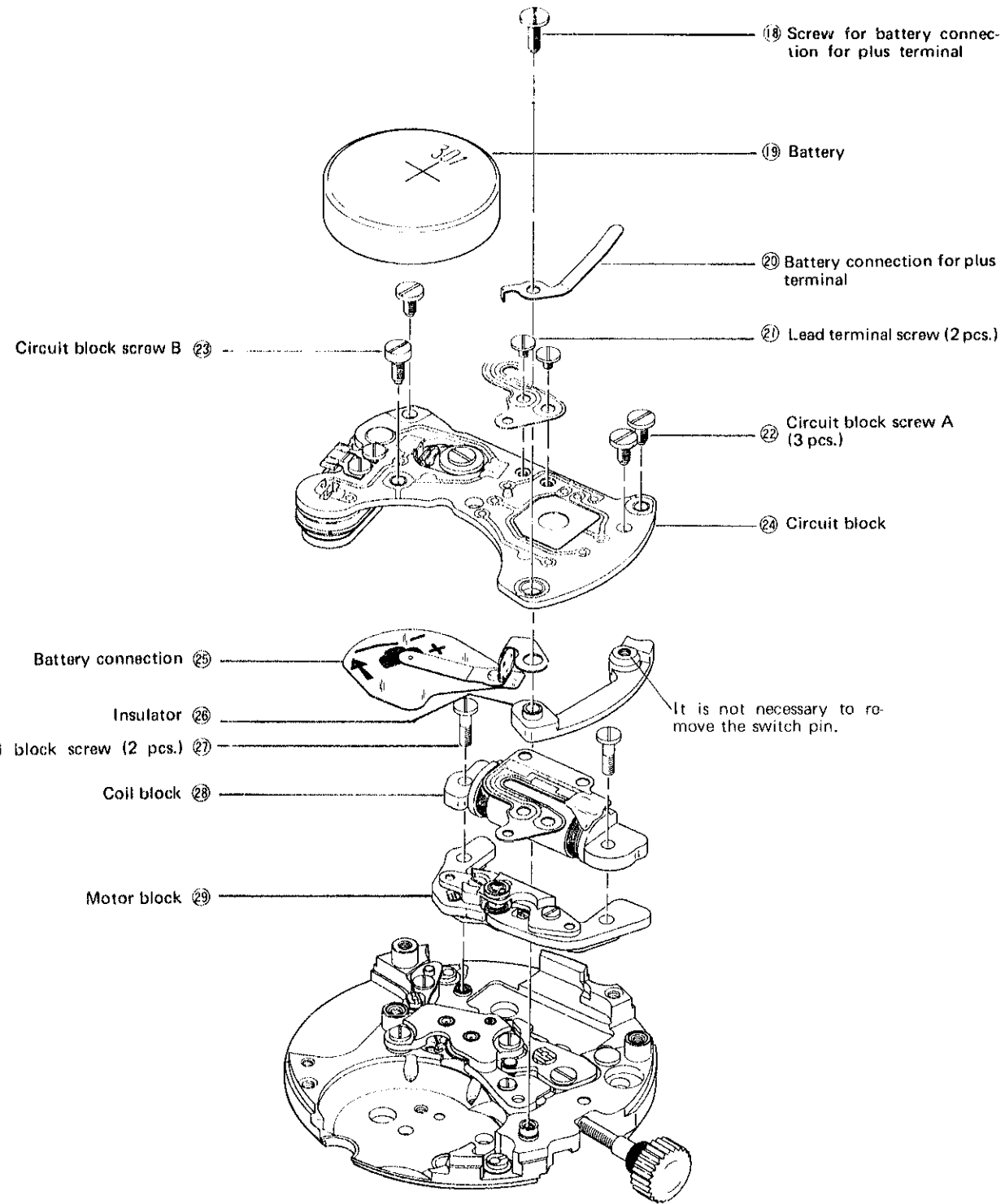

REMARKS:

Replacing the battery 19

- (1) Check for a battery voltage reading of over 1.5 V before placing it in the case.
- (2) Wipe off any foreign matter with a dry cloth.
- (3) Use battery U.C.C. 301

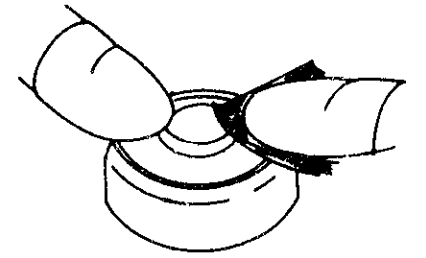

Circuit Block 24

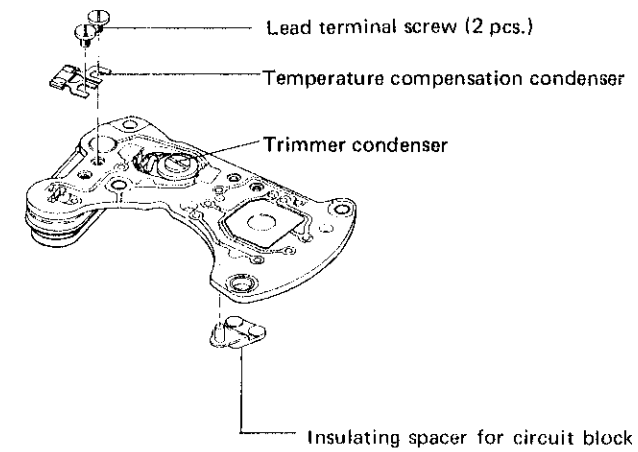

- It is not necessary to remove the insulating spacer for circuit block under normal disassembling conditions.
- Time accuracy is adjusted by turning the trimmer condenser. But, do not remove the temperature compensation condenser.

Hold the coil block 28

Hold the coil block as shown in a photo.

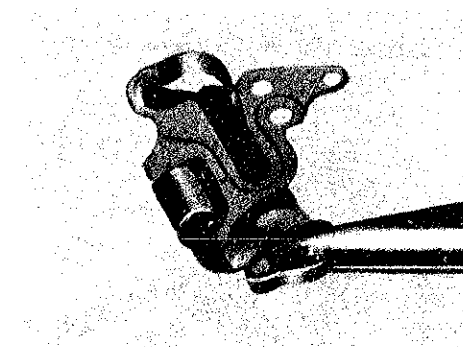

Correct

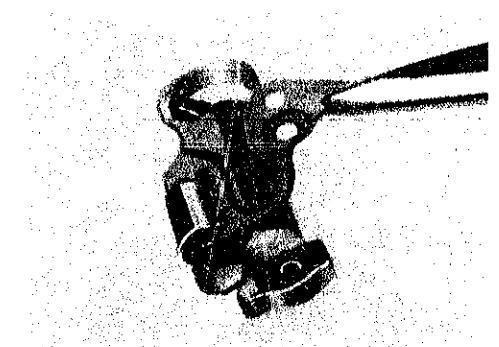

Incorrect

Motor block 29

It is not necessary to disassemble except when foreign matter is found inside.

3. Gear train mechanism

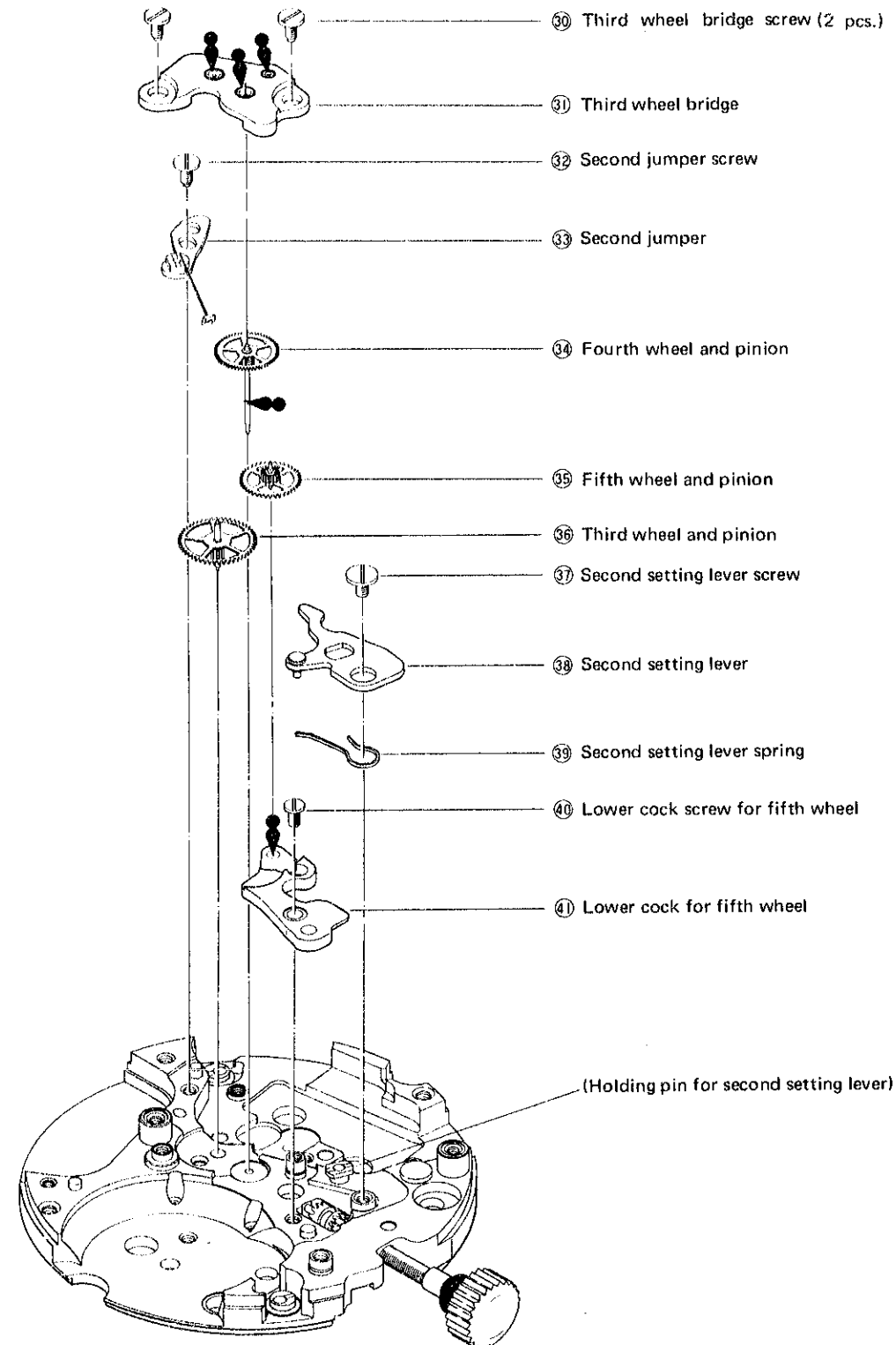

REMARKS:

Reassembling procedures for the second jumper 33

Determine the second jumper position after assembling the motor block and coil block.

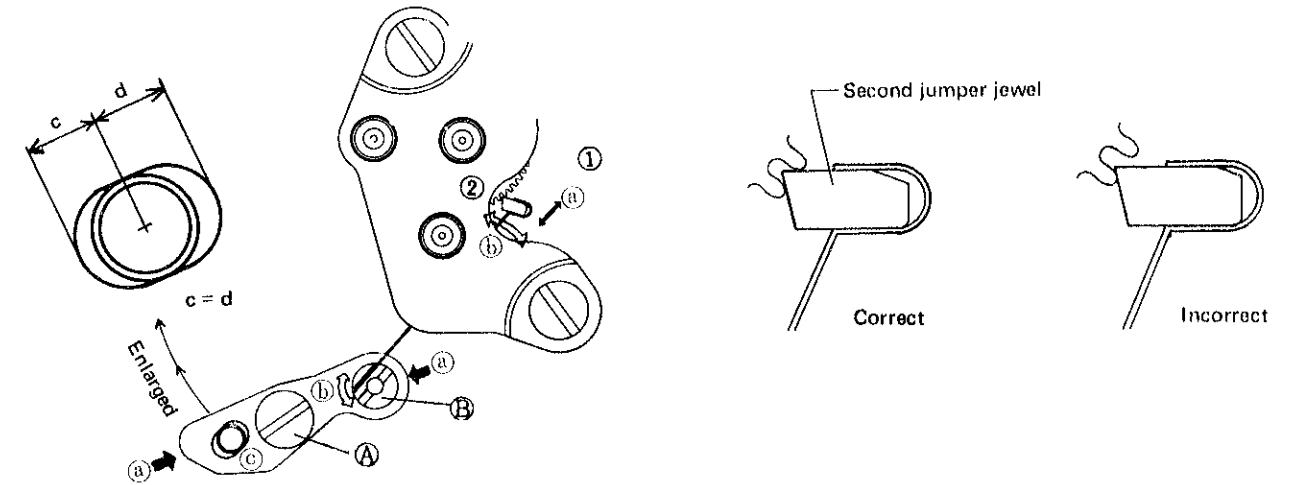

Reassembling procedures:

- (1) Fix the second jumper so that a pin of the main plate (c) can be placed in the center of the oval hole of the second jumper.
- (2) Loosen the (A) screw a little and adjust the second jumper in the arrow marked direction (a) and then tighten it.
- (3) Turn the (B) pin and adjust the second jumper spring in the arrow marked direction (b).
- (4) Be sure that no pressure is put on the fourth wheel and pinion by the second jumper jewel. Also make sure that the fourth wheel cog meet exactly with the second jumper jewel. Be careful second jumper jewel not to bend the second jumper spring.

How to assemble the second-setting lever 37 38

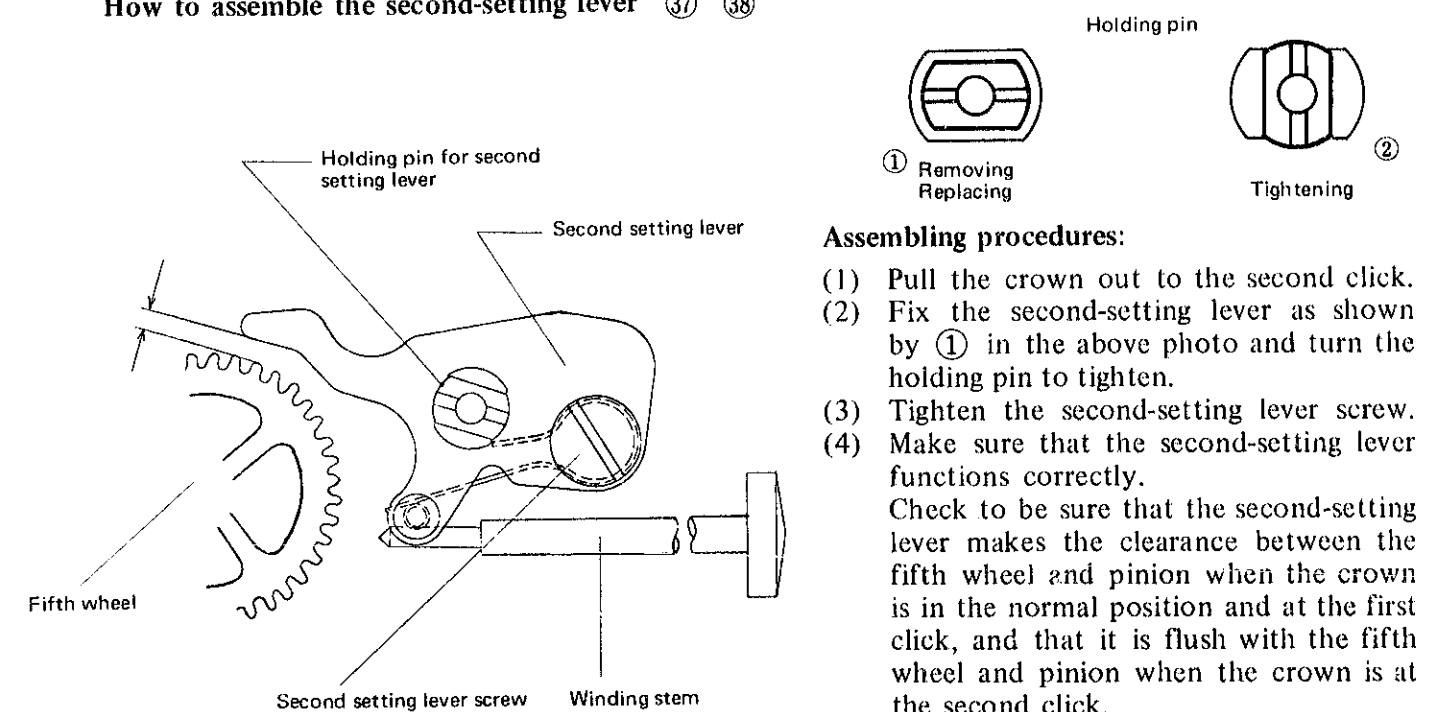

Assembling procedures:

- (1) Pull the crown out to the second click.
- (2) Fix the second-setting lever as shown by 1 in the above photo and turn the holding pin to tighten.
- (3) Tighten the second-setting lever screw.
- (4) Make sure that the second-setting lever functions correctly. Check to be sure that the second-setting lever makes the clearance between the fifth wheel and pinion when the crown is in the normal position and at the first click, and that it is flush with the fifth wheel and pinion when the crown is at the second click.

4. Setting mechanism

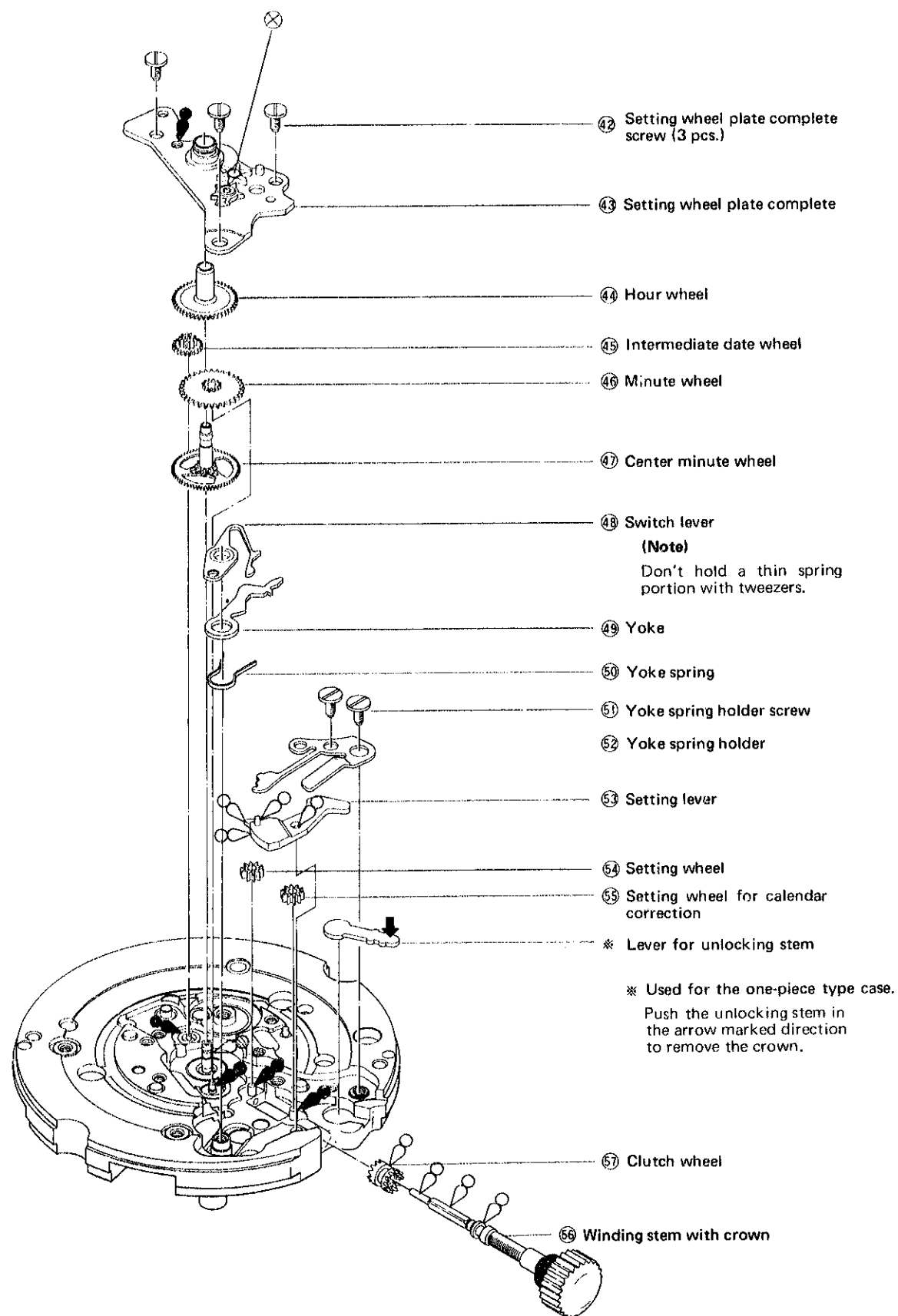

REMARKS:

Lubrication of setting wheel plate complete ④③

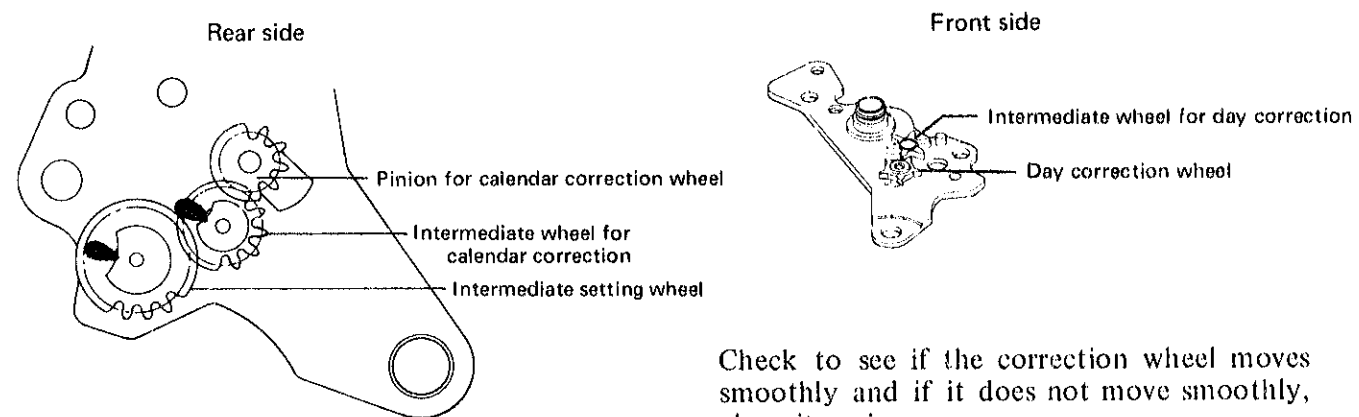

Check to see if the correction wheel moves smoothly and if it does not move smoothly, clean it again.

Lubrication of center minute wheel ④⑦

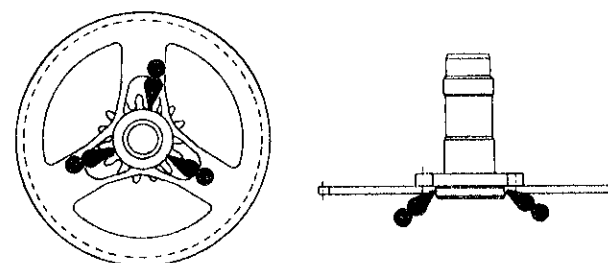

Don't disassemble the cannon pinion and center minute wheel.

How to assemble the yoke and yoke spring ④⑨ ⑤①

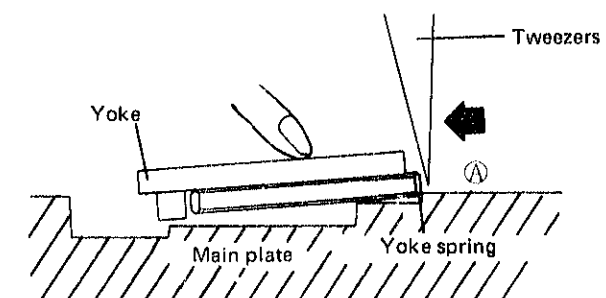
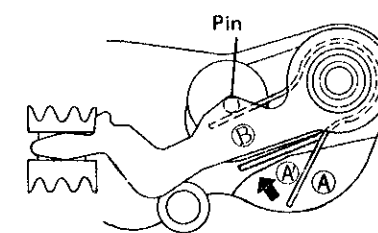

- (1) Put the fork of the yoke spring on the (A) side of the main plate as shown in the diagram.
- (2) Put the fork of the yoke spring on the (B) side as shown in the diagram.
- (3) Hold the yoke with a finger as shown in the above illustration and push the yoke spring from (A) to (A) position in the arrow marked direction.

Place the clutch wheel with the L side (long side) facing the center minute wheel and the l side (short side) facing the crown.

Clutch wheel ⑤⑦

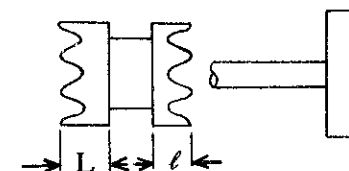

5. Motor block

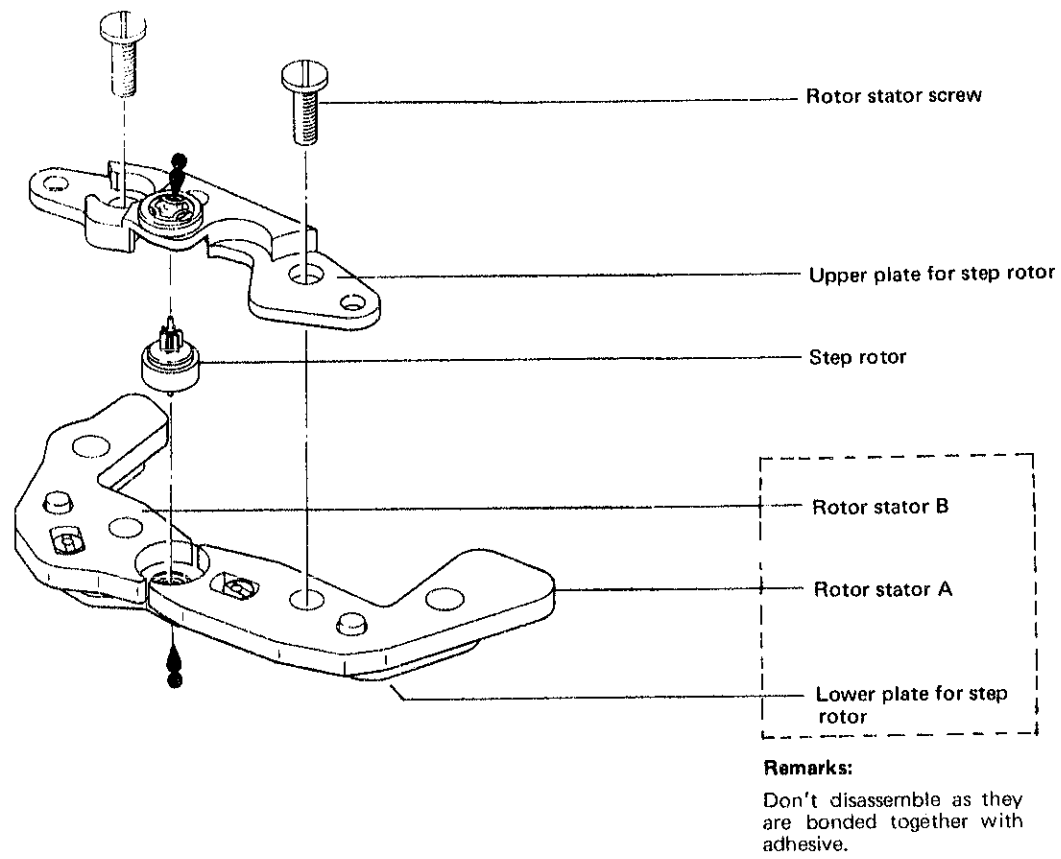



REMARKS:

- Don't disassemble the lower plate for step rotor and rotor stators (A.B.) as they are bonded together with adhesive after adjustment.
- Use adhesive tape or RODIKO to remove the filing and lint from the step rotor.

6. Cleaning

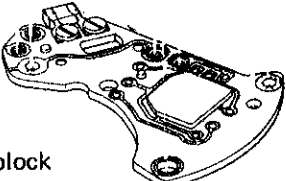
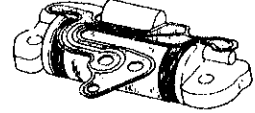
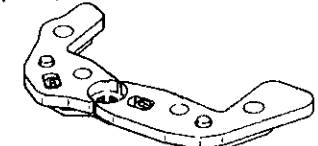
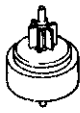
Since several special parts (electronic, plastic, etc.) are used in the SEIKO Quartz Cal. 0843A, use the following cleaning methods when cleaning.

Name of Parts	Cleaning	Drying	Solution	Remarks
Circuit block  Coil block 	DO NOT CLEAN			Conducting portion <u>ONLY</u> may be cleaned with a cloth moistened with benzine or alcohol. Dry in <u>COOL</u> air.
Rotor stator (with lower plate)  Step rotor  Second jumper 	Rinse or gently scrub with brush	Cool air drying	Benzine	<ul style="list-style-type: none"> Don't disassemble the lower plate and rotor stator as they are bonded. Don't use trichloroethylene and alcohol. Use a clean solution as the step rotor has a magnet. Be careful not to bend the spring or remove a jewel of the second jumper.
Plastic parts	Rinse or gently scrub with brush	Cool air drying	Alcohol or benzine	
Parts other than the above	Clean with cleaner, rinse or gently scrub with brush	Cool or hot air drying	Benzine or trichloroethylene	

CHECKING AND ADJUSTMENT

1. Guide for Checking and Adjustment

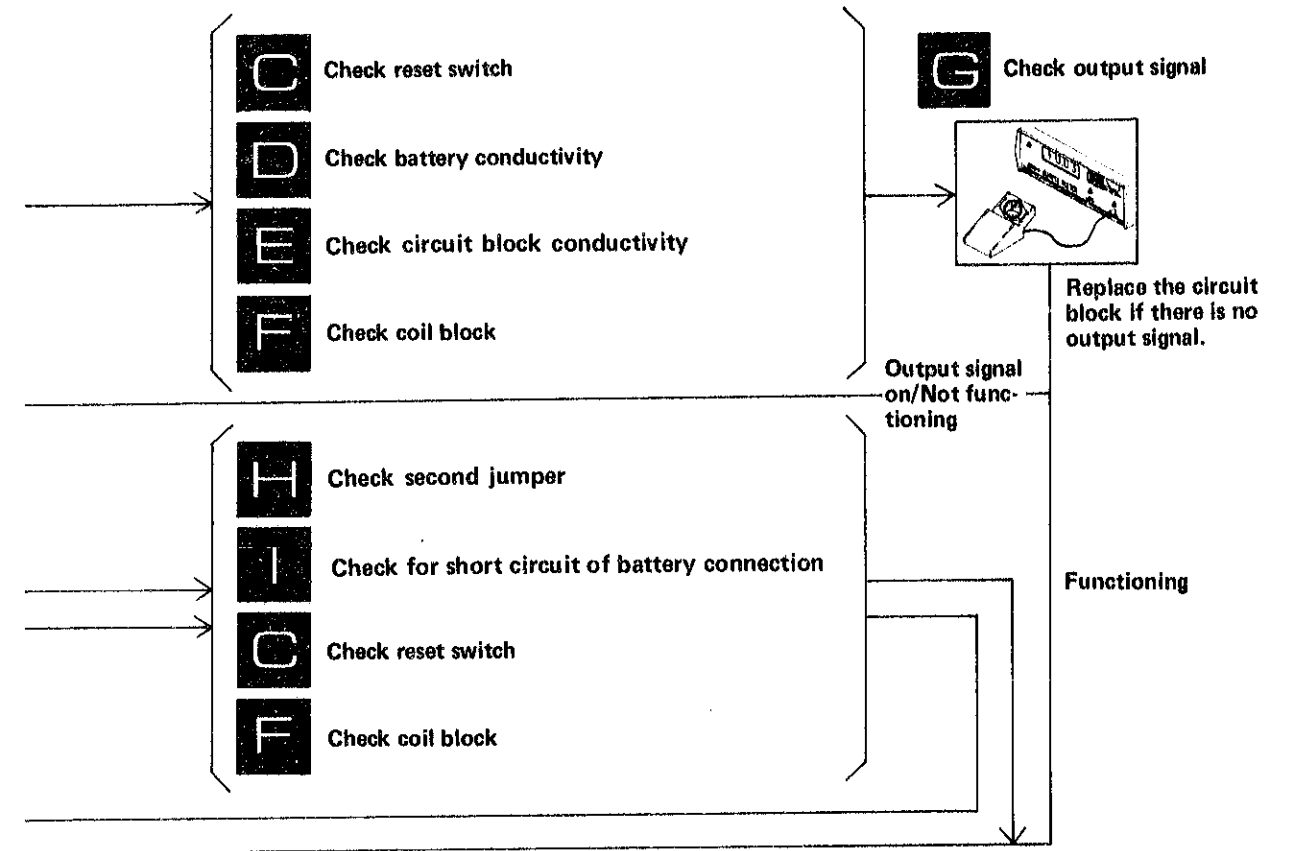
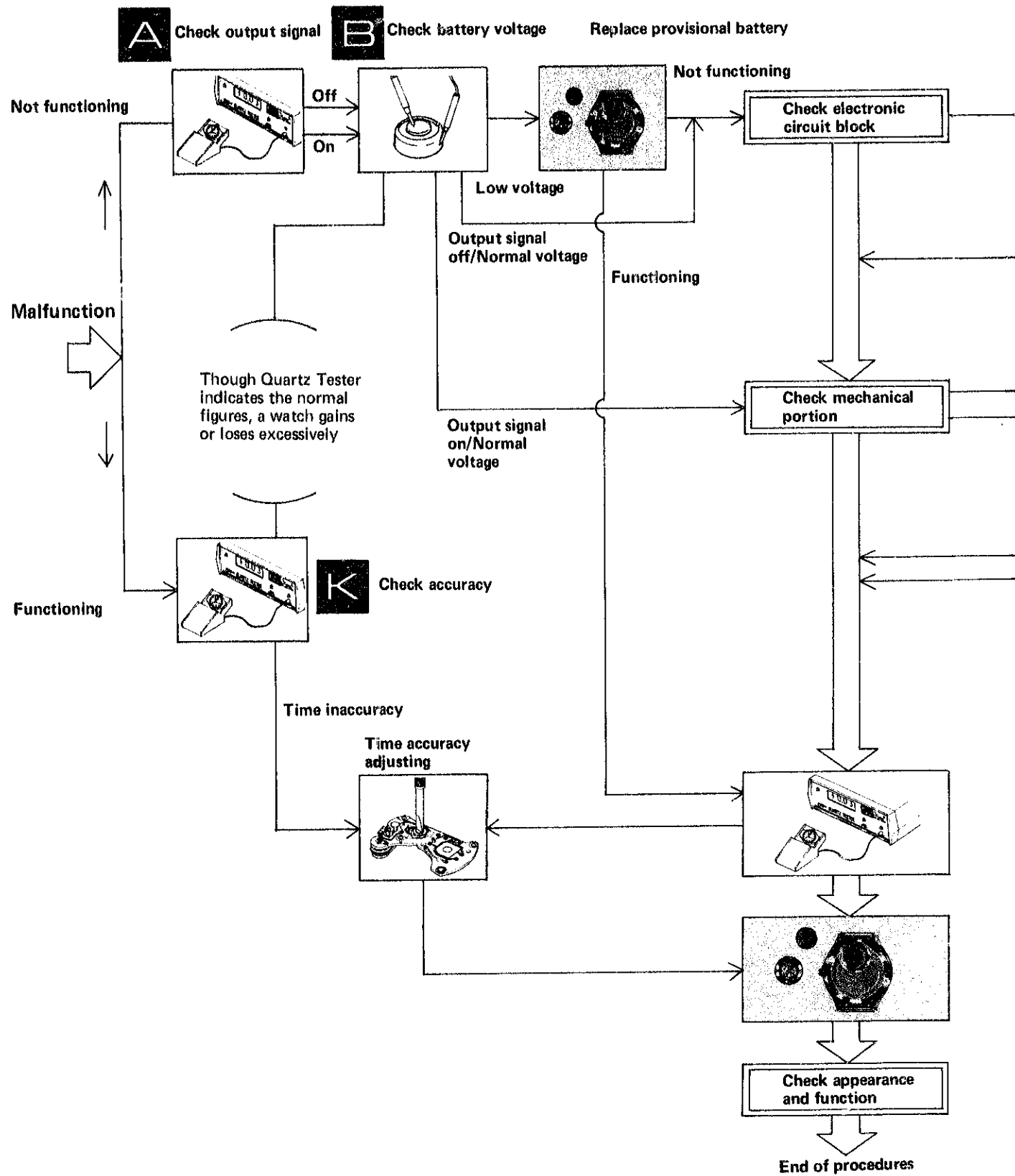

K Check accuracy





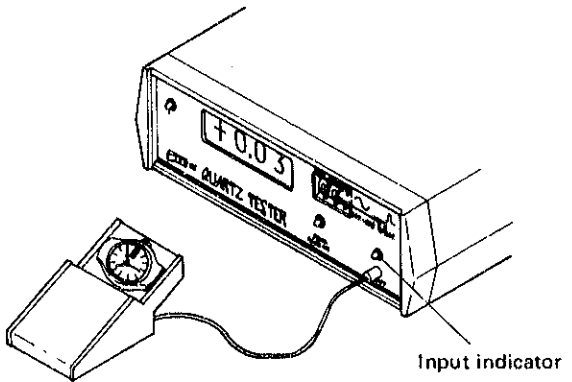
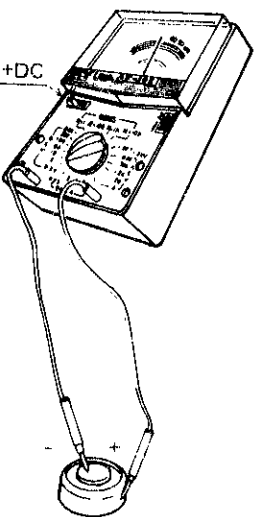
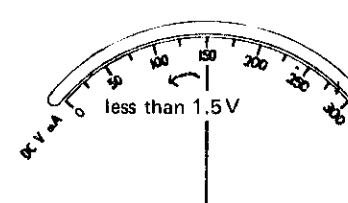
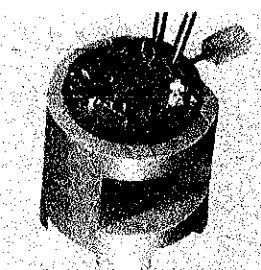
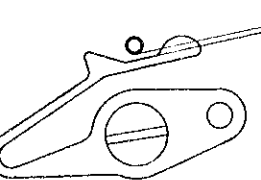

Replace the battery

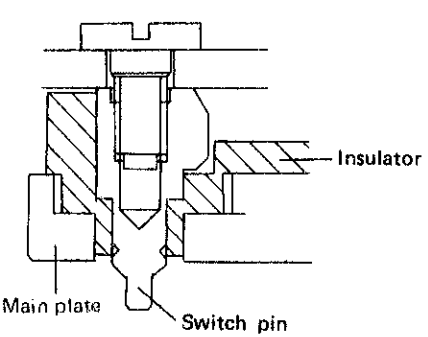
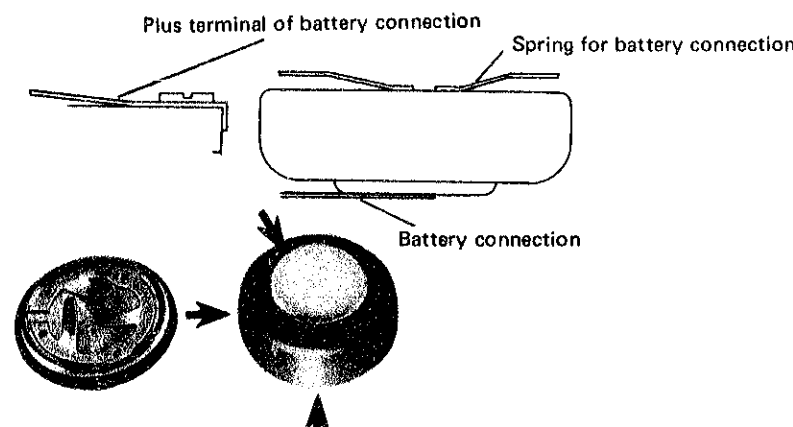
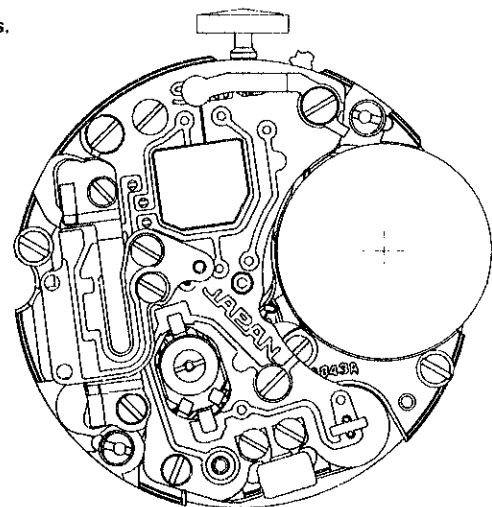
In cases where a frequent battery change is required a current consumption test is recommended (see page 26 for measurement).

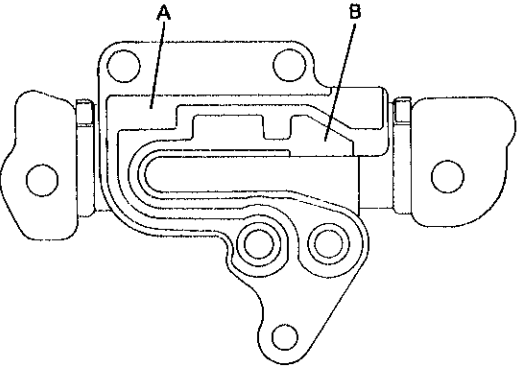
2. Procedures for Checking and Adjustment

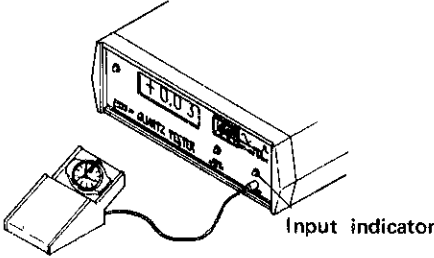
	Procedures	Results	Adjustment and Repair
CHECK OUTPUT SIGNAL	<p>A</p> <p>Check for output signal.</p> <p>1. Set up the Quartz Tester</p>  <p>2. Checking Check for an output signal.</p>	<p>One-second blinking</p> <p>No one-second blinking</p> <p>(including the cases where it is lit continuously or does not blink once per second)</p>	<p>Proceed to B</p>
CHECK BATTERY VOLTAGE	<p>B</p> <p>Use the following procedures to check battery voltage.</p> <p>1. Set up the tester Range to be used DC 3V</p>  <p>2. Measuring</p> <ul style="list-style-type: none"> Probe Red (+) Battery surface (+) Probe Black (-) Battery surface (-) <p>(Note) When handling the battery, use non-metallic tweezers or a fingercod.</p>	<p>More than a 1.5 V reading indicates</p> <p>Less than a 1.5 V reading indicates</p> 	<p>In procedure A if one-second blinking is found, check the Mechanical Portion</p> <p>In procedure A if one-second blinking is NOT found, check the Electronic Circuit Block</p> <p>Replace with a provisional battery</p> <p>• If a watch operates after battery replacement, proceed to K</p> <p>• If a watch does not operate, check the Electronic Circuit Block</p>
CHECK RESET SWITCH	<p>C</p> <p>Check for a short circuit of the switch pin and main plate when the crown is at the normal position and when it is pulled out to the first click.</p> <p>Remove the circuit block.</p> <p>Set up the tester Range to be used OHMS R x 1</p> <p>C₁ First check</p> <p>Check for a short circuit of the switch pin and main plate. Touch the red and black probes to the main plate and switch pin when the crown is at the normal position and pulled out to the first click (there is no difference between the red and black probes).</p>  <p>C₂ Second check</p> <p>Check to see if there is clearance between the switch lever and switch pin when the crown is at the normal position and when it is pulled out to the first click.</p> 	<p>When the needle of the tester does not move</p> <p>When the needle of the tester moves</p> <p>Clearance</p> <p>No clearance</p>	<p>Proceed to D</p> <p>Proceed to C₂</p> <p>Proceed to C₃</p> <p>Replace the switch lever</p>

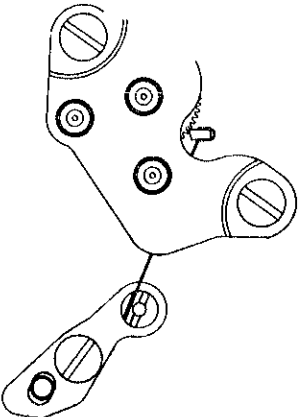
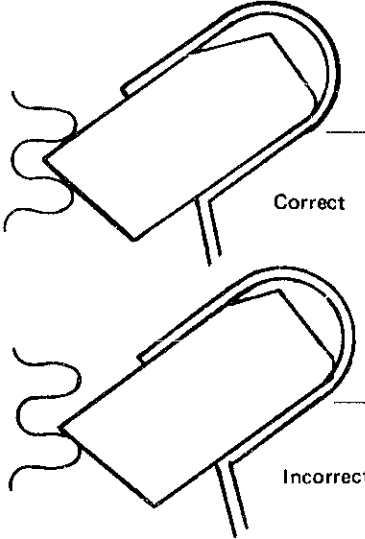
	Procedures	Results	Adjustment and Repair
<p>C</p> <p>CHECK RESET SWITCH</p>	<p>Ca Third check</p> <p>Check for foreign matter on the insulator between the switch pin and the main plate.</p> 	<p>No foreign matter, uncontaminated →</p> <p>Foreign matter, contaminated →</p>	<p>Proceed to D</p> <p>Wipe off carefully.</p>
<p>D</p> <p>CHECK BATTERY CONDUCTIVITY</p>	<p>Use the following procedures to check to see if the battery current flow to the circuit is normal.</p> <p>1. First check</p> <p>Check for any foreign matter on the connecting point of the battery, spring for battery connection, the battery connection and the plus terminal of the battery connection.</p>  <p>2. Second check</p> <p>Make sure that the plus terminal screw of the battery connection is tightened firmly.</p>	<p>Uncontaminated →</p> <p>Contaminated →</p> <p>No loosened screw →</p> <p>Loosened screw →</p>	<p>Proceed to D</p> <p>Wipe off carefully.</p> <p>Proceed to E</p> <p>Retighten screws</p>
<p>F</p> <p>CHECK CIRCUIT BLOCK CONDUCTIVITY</p>	<p>Check for short circuit and defective contact of the circuit block conducting portions.</p> <p>Check the eight (8) screws in the diagram below for looseness.</p> 	<p>No loosened screw →</p> <p>Loosened screw →</p>	<p>Proceed to F</p> <p>Retighten screw. Be careful not to tighten them excessively.</p>

	Procedures	Results	Adjustment and Repair
CHECK COIL BLOCK	<p>Remove the circuit block and check for broken coil wire and short circuit of the coil block.</p> <p>1. Set up the tester Range to be used OHMS R x 100</p> <p>2. Checking method Touch the probes of the tester to the two terminals (A and B) of coil respectively.</p> 	<p>3.0 KΩ ~ 5.0 KΩ</p> <p>More than 5.0 KΩ (Broken wire)</p> <p>Less than 3.0 KΩ (Short circuit)</p>	<p>Proceed to </p> <ul style="list-style-type: none"> Replace the coil block
CHECK OUTPUT SIGNAL	<p>Check the output signal.</p> <p>1. Set up the Quartz Tester</p> <p>2. Checking method Check for output signal (Blinking input indication light)</p> 	<p>One blink per second — Watch functioning</p> <p> Not functioning</p> <p>No blinking</p>	<p>Proceed to </p> <ul style="list-style-type: none"> Check the Mechanical block. Replace the circuit block.
CHECK SECOND JUMPER	<p>H₁ Check to see if the second jumper jewel gears with the fourth wheel and pinion exactly.</p> 	 <p>Correct</p> <p>Incorrect</p>	<p>Proceed to  2</p> <p>Adjust the second jumper</p>

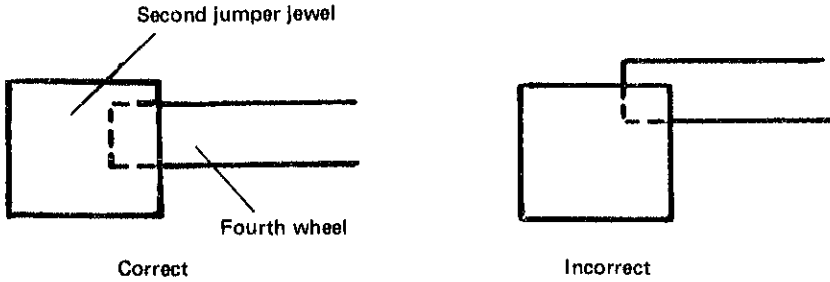
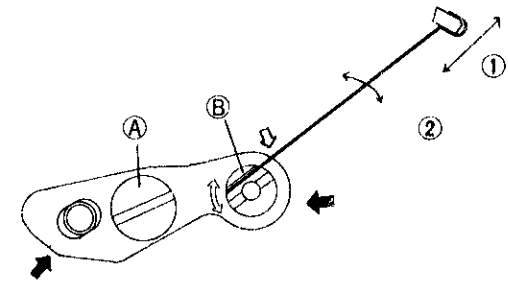
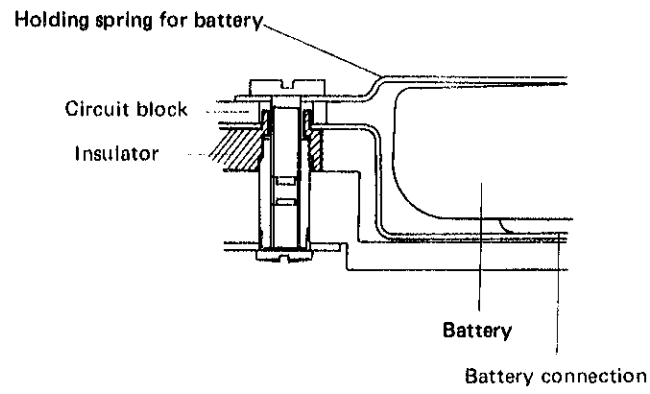
	Procedures	Results	Adjustment and Repair
I CHECK SECOND JUMPER	<p>He. Check to see if the second jumper jewel is at the proper height.</p>  <p>Second jumper jewel</p> <p>Fourth wheel</p> <p>Correct</p> <p>Incorrect</p>	<p>More than the thickness of the fourth wheel</p> <p>Less than the thickness of the fourth wheel</p>	 <ol style="list-style-type: none"> After loosening the screw (A), adjust second jumper ① by pushing in the arrow-marked direction (⇒). Retighten the screw (A) after adjustment. Adjust in the direction of ② by turning the pin (B) (⇔). <p>Proceed to I</p> <p>Adjust the foot of the pin (⇒) with a pair of tweezers. (see the above diagram)</p>
I CHECK FOR SHORT CIRCUIT OF BATTERY CONNECTION	<p>Check for short circuit of the main plate and the battery connection.</p>  <p>Holding spring for battery</p> <p>Circuit block</p> <p>Insulator</p> <p>Battery</p> <p>Battery connection</p> <p>Check for short circuit of the battery connection, holding spring for battery, battery and the main plate by filings, etc.</p>	<p>Normal condition</p> <p>Short circuit</p>	<p>Proceed to J</p> <p>If not functioning, check F</p> <p>• Wipe off the foreign matter.</p>

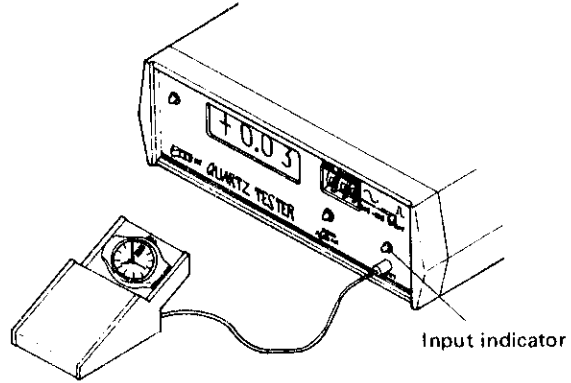
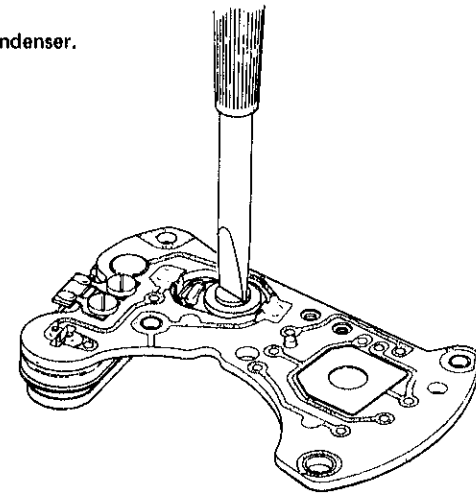
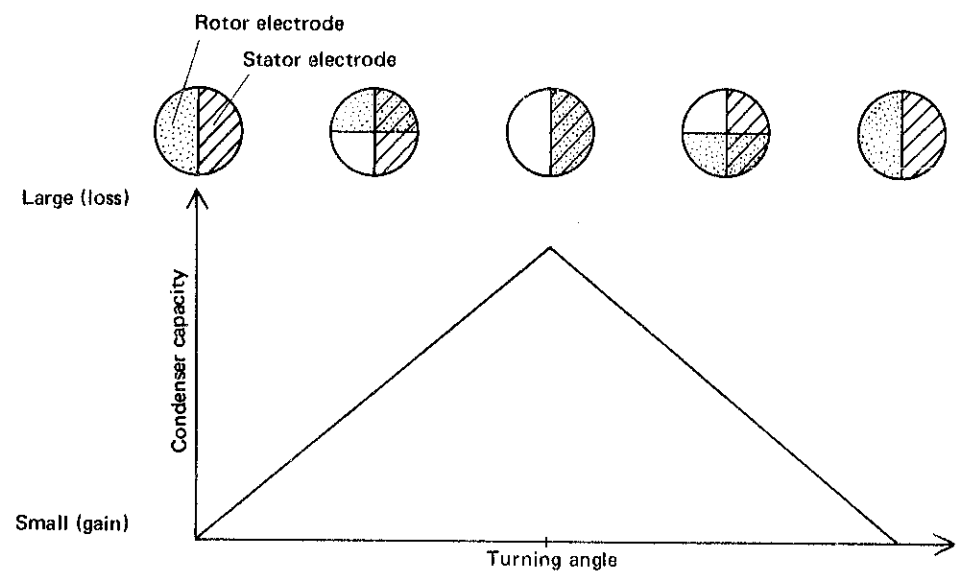
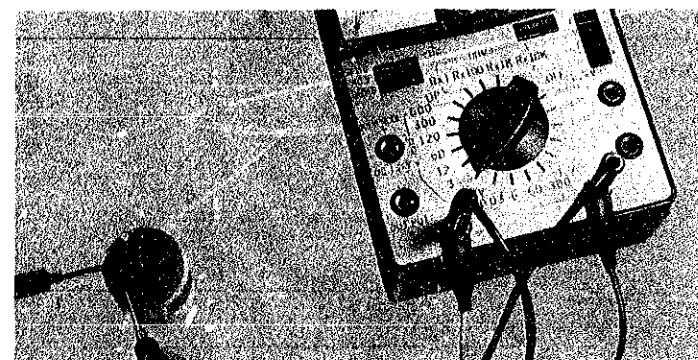
	Procedures	Results	Adjustment and Repair
CHECK ACCURACY	<p>Check gain and loss of time.</p> <ul style="list-style-type: none"> Set up the Quartz Tester 	<p>Normal</p> <p>Defective</p>	<div data-bbox="2410 340 2813 415" style="border: 1px solid black; padding: 2px; margin-bottom: 10px;">Check the appearance and Function</div> <div data-bbox="2410 520 2665 596" style="border: 1px solid black; padding: 2px;">Adjust time accuracy</div>
TIME ACCURACY ADJUSTING METHOD	<p>Time accuracy is adjusted by turning the trimmer condenser.</p>  <ul style="list-style-type: none"> Adjustment should be made after ascertaining by the Quartz Tester whether the watch tends to gain or lose. The watch gains or loses according to the direction in which the trimmer condenser is turned. Note for handling of Trimmer Condenser <ul style="list-style-type: none"> (1) Avoid excessive depressing. (2) Avoid turning the Trimmer Condenser unnecessarily. 	<ul style="list-style-type: none"> Capacity of Trimmer Condenser The capacity is changed by turning the Trimmer Condenser as shown in the diagram below. 	
MEASURING CURRENT CONSUMPTION	<p>In cases where a frequent battery change is required, a current consumption test is recommended. Use the following procedures:</p>  <p>Procedures:</p> <ol style="list-style-type: none"> Set up the Tester <ul style="list-style-type: none"> Range to be used DC 0.03mA Set up the condenser of 200 ~ 500 μF as shown in a photo. 	<ol style="list-style-type: none"> Measurement <ul style="list-style-type: none"> Probe Red (+) Battery surface (+) Probe Black (-) Circuit block <p>Check the current consumption when the crown is at the normal position and when it is pulled out to the first click. When the current consumption is more than 10 μA, follow procedures F and I</p>	