

**LASSALE
SEIKO**

QUARTZ

Cal. 2F50A

**PARTS
CATALOGUE**

Cal. 2F50A



125 356



231 356



241 335



261 356



☆270 335



☆271 335



281 356



282 356



☆351 356



383 356



384 356



388 356



391 356



491 271



701 356



4000 356



4002 356



4146 356



4239 356



4270 356



4271 356



4408 356



4408 357



4457 334



☆SEIKO SR512SW



012 056



012 830



012 831



032 026



032 027



032 028

Cal. 2F50A

Characteristics

Casing diameter : 15.1 mm
 Maximum height : 1.3 mm
 Jewels : 12 j
 Frequency of quartz crystal oscillator : 32,768 Hz (Hz=Hertz..... Cycles per second)
 Driving system : Step Motor (2 poles)
 Regulation system : Chip condenser
 Train wheel setting

PART NO.	PART NAME	PART NO.	PART NAME
125 356	Train wheel bridge	012 830	Circuit block screw
231 356	Third wheel & pinion	012 830	Setting lever spring screw
241 335	Fourth wheel & pinion	012 831	Dial screw
261 356	Minute wheel	032 026	Tube for train wheel bridge
☆270 334	Center minute wheel	032 027	Tube for coil block
☆ 270 335		032 028	Tube for circuit block
☆270 336		☆ SEIKO SR512SW	Silver (II) oxide battery
☆270 337		☆ Maxell SR512SW	
☆271 334		Hour wheel	
☆ 271 335			
☆271 336			
☆271 337			
281 356	Setting wheel		
282 356	Clutch wheel		
☆ 351 356	Winding stem (7.7 mm)		
☆351 357	Winding stem (10.0 mm)		
☆351 358	Winding stem (12.4 mm)		
☆351 359	Winding stem with gasket (7.0 mm)		
☆351 360	Winding stem (15.4 mm)		
383 356	Setting lever		
384 356	Yoke		
388 356	Setting lever spring		
391 356	Train wheel setting lever		
491 271	Dial washer		
701 356	Fifth wheel & pinion		
4000 356	Circuit block		
4002 356	Coil block		
4146 356	Step rotor		
4239 356	Rotor stator		
4270 356	Battery connection (-)		
4271 356	Battery connection (+)		
4408 356	Setting lever spring spacer		
4408 357	Circuit block spacer		
4457 334	Circuit block cover		
011 561	Upper hole jewel for center wheel		
011 562	Upper hole jewel for step rotor		
011 562	Lower hole jewel for step rotor		
011 562	Upper hole jewel for third wheel		
011 562	Lower hole jewel for third wheel		
011 562	Upper hole jewel for fourth wheel		
011 562	Lower hole jewel for fourth wheel		
011 562	Upper hole jewel for fifth wheel		
011 562	Lower hole jewel for fifth wheel		
011 563	Upper hole jewel for minute wheel		
011 567	Lower hole jewel for minute wheel		
011 737	Lower hole jewel for center wheel		
012 056	Train wheel bridge screw		







☆ □ Please see remarks on the reverse page.
 Part numbers in light letters are not shown in photos.

Cal. 2F50A

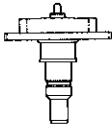
Remarks :

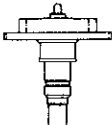
Center minute wheel, Hour wheel

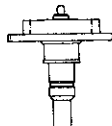
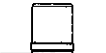
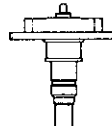
There are four different types as specified below.
Combination :

Type	Center minute wheel	Hour wheel
a	 ☆270 334	 ☆271 334
b	 ☆270 335	 ☆271 335
c	 ☆270 336	 ☆271 336
d	 ☆270 337	 ☆271 337

Winding stem

- ☆351 356
- ☆351 357
- ☆351 358
- ☆351 359
- ☆351 360

Refer to the photograph on the front page.
If the combination of the winding stem and case is unknown, check the case number and refer to "SEIKO Quartz Casing Parts Catalogue" to choose a corresponding winding stem.

TECHNICAL GUIDE

LASSALE SEIKO

QUARTZ

CAL. 2F50A

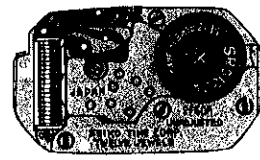
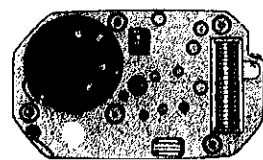

CONTENTS

I. SPECIFICATIONS	1
II. STRUCTURE OF THE CIRCUIT BLOCK	1
III. DISASSEMBLING, REASSEMBLING, AND LUBRICATING	2
1. Hour and minute hands ~ Dial	2
2. Battery ~ Battery connection (+)	4
3. Train wheel bridge screw ~ Hour wheel	5
4. Setting lever spring screw ~ Stem with crown	6
IV. CHECKING AND ADJUSTMENT	7
• Check output signal	7
• Check hands setting condition	7
• Check battery voltage	7
• Check battery conductivity	7
• Check conductivity of circuit block	7
• Check coil block	7
• Check gear train mechanism	8
• Check reset and train wheel setting condition	8
• Check current consumption	9
• Check accuracy	9
• Check appearance and functioning	9

I. SPECIFICATIONS

Cal. No.		2F50A
Item		
Time indication		2 hands (Moves at every 20 seconds)
Driving system		Step motor (Fixed-width pulse system)
Additional mechanism		<ul style="list-style-type: none"> • Electronic circuit reset switch • Train wheel setting device
Loss/gain		Monthly rate at normal temperature range: less than 15 seconds
Movement size	Outside diameter	15.5 mm between 6 o'clock and 12 o'clock sides 9.5 mm between 3 o'clock and 9 o'clock sides
	Casing diameter	φ15.1 mm
	Height	1.3 mm
Regulation system		—
Measuring gate by quartz tester		Use the 10-second gate
Battery		Miniature battery, SEIKO (SEIZAIKEN) SR512SW, Maxell SR512SW Battery life is approximately 2 years. Voltage: 1.55V
Jewels		12 jewels

II. STRUCTURE OF THE CIRCUIT BLOCK

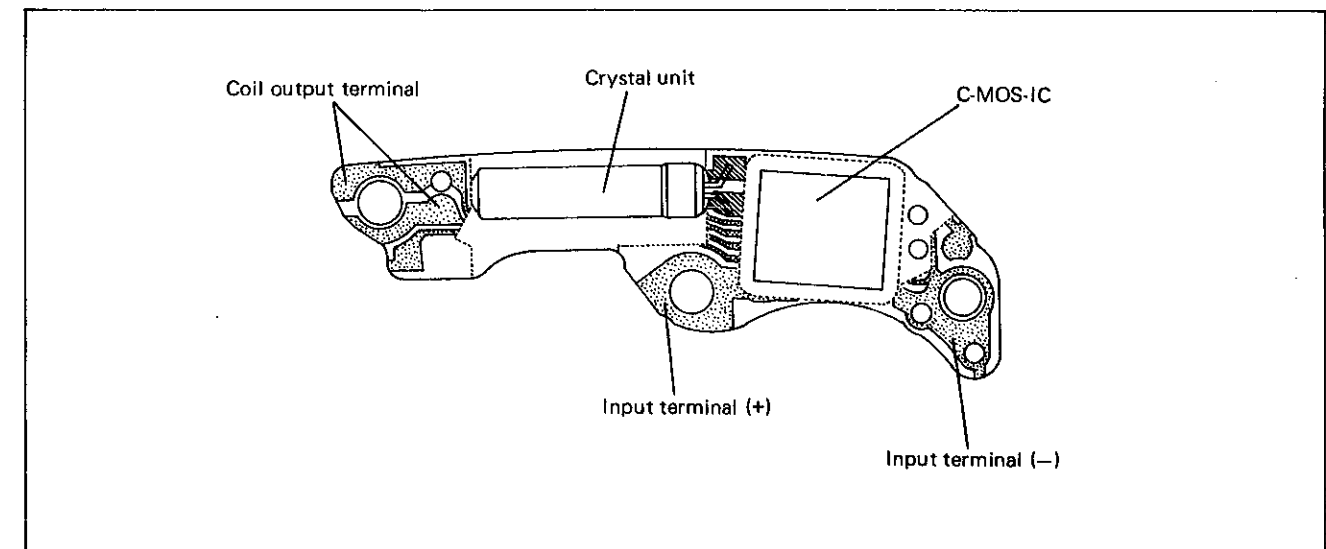

III. DISASSEMBLING, REASSEMBLING, AND LUBRICATING

List of the screws used

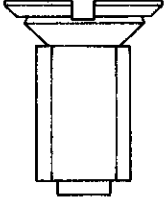
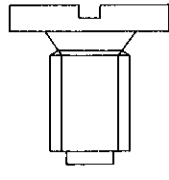
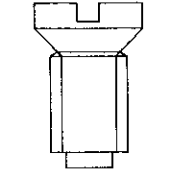
Shape	Part No.	Name	Shape	Part No.	Name
	012 830	Circuit block screw (3 pcs.) Setting lever spring screw (1 pc.)		012 056	Train wheel bridge screw (2 pcs.)
				012 831	Dial screw (1 pc.)

Disassembling procedures Figs. : ① → ③①

Reassembling procedures Figs. : ③① → ①

Lubricating

Types of oil:

- Moebius A
- SEIKO Watch Oil S-6

Oil quantity:

- Normal quantity
- Extremely small

- Use the movement holder S-681 for disassembling and reassembling.

1. Hour and minute hands ~ Dial

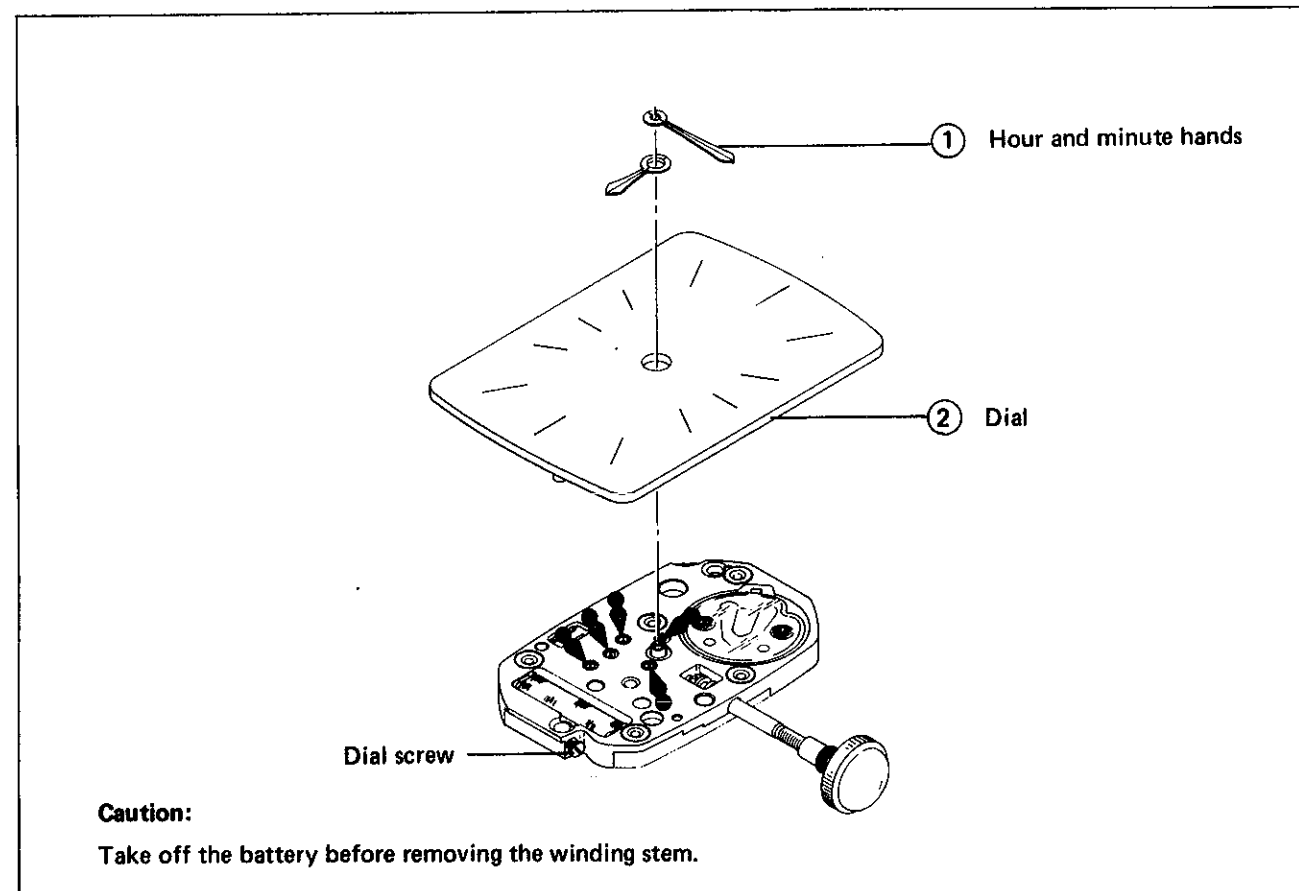

Remarks on disassembling and reassembling

① Hour and minute hands

● How to disassemble the hour and minute hands

As this watch has only a little clearance between the dial and the hands, the bow-type hand remover cannot be used. Disassemble the hands by following the instructions below.

1. Prepare a vinyl sheet and make a small hole in the center of it. (Ex.: Use a vinyl bag for spare parts container.)
2. Set the vinyl sheet so that the minute hand comes out through the hole of the vinyl sheet.
3. Hold the one end of the vinyl sheet with finger and pull the other side up to disassemble the minute hand. When holding the vinyl sheet with finger, be careful not to scratch the dial surface with nail.

Disassemble the hour hand, following the same procedures.

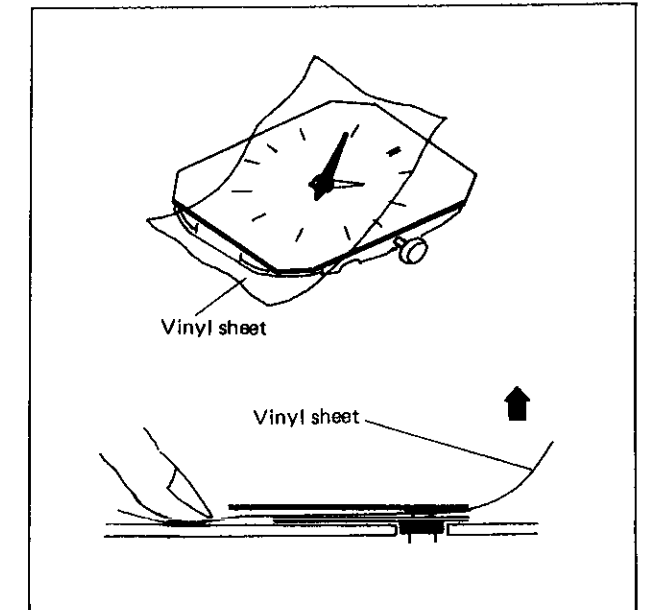

● How to reassemble the hour and minute hands

Use the movement holder S-681.

Place a vinyl sheet on the dial so as not to scratch it.

When pushing in the hands, be careful not to apply undue force on the dial and the movement to prevent them from being deformed.

After having pushed in the hands, their setting condition cannot be adjusted. Be sure to push them in one by one so that they are set horizontally.

② Dial

The dial is fixed with the dial screw on the 6 o'clock side, but the dial screw is not used on the 12 o'clock side because it is held with the circuit block spacer.

After setting the dial, check to see if it is correctly set level.

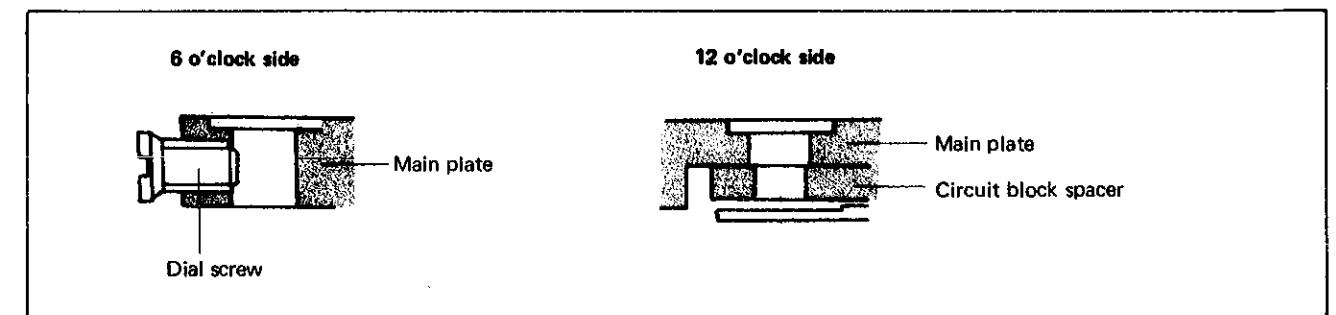

2. Battery ~ Battery connection (+)

③ Battery

Remarks on reassembling
Install the battery first at the battery connection (+) side, and then press the other side of the battery down lightly.

Note:
Do not apply undue force to press the battery, since this may deform the dial.

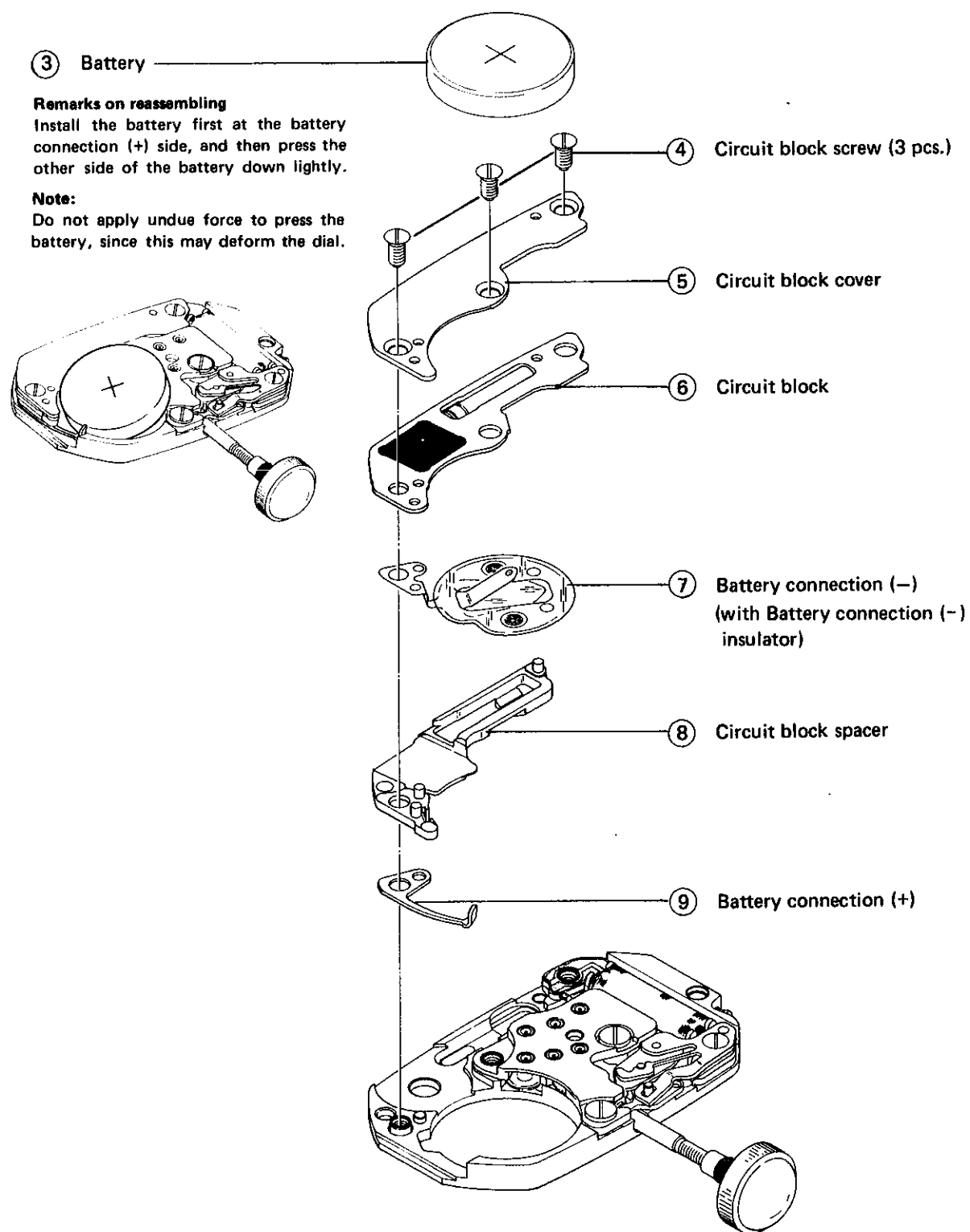

3. Train wheel bridge screw ~ Hour wheel

Setting position of ⑫ ~ ⑱

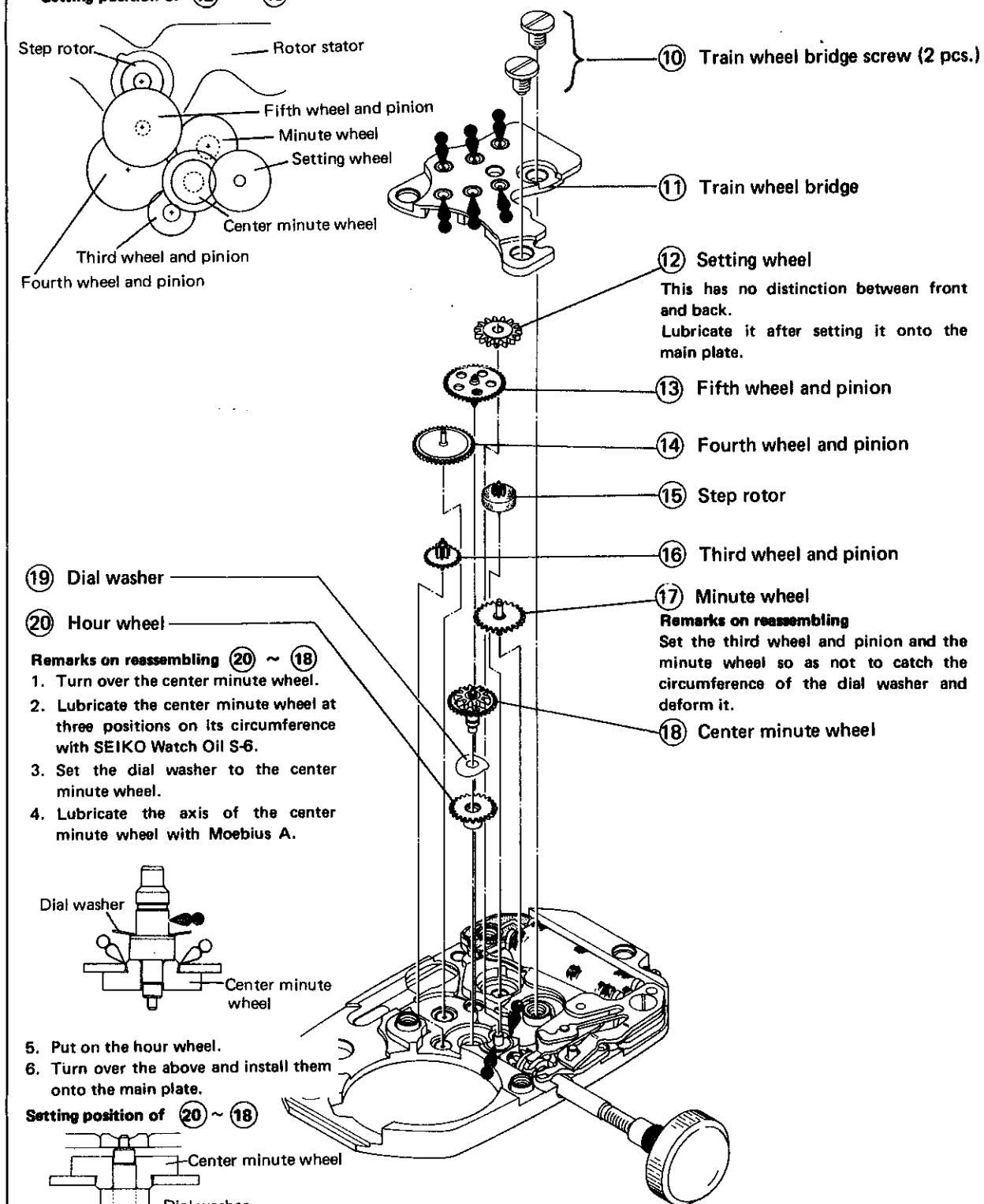

Remarks on reassembling ⑳ ~ ⑱

1. Turn over the center minute wheel.
2. Lubricate the center minute wheel at three positions on its circumference with SEIKO Watch Oil S-6.
3. Set the dial washer to the center minute wheel.
4. Lubricate the axis of the center minute wheel with Moebius A.

Setting position of ⑳ ~ ⑱

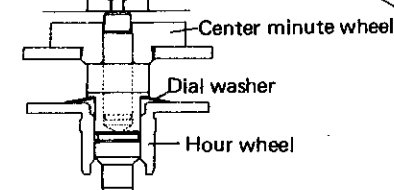

Remarks on reassembling
This has no distinction between front and back. Lubricate it after setting it onto the main plate.

Remarks on reassembling
Set the third wheel and pinion and the minute wheel so as not to catch the circumference of the dial washer and deform it.

4. Setting lever spring screw ~ Stem with crown

Setting position of ⑳ ~ ㉓

Caution:
Do not pull out or push in the stem with crown before tightening the train wheel bridge screws (2 pcs.). Otherwise, the train wheel setting lever does not operate normally.

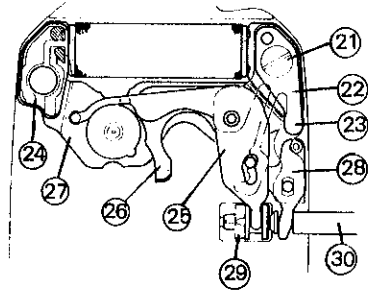

Setting position of ㉔ setting lever and ㉕ train wheel setting lever

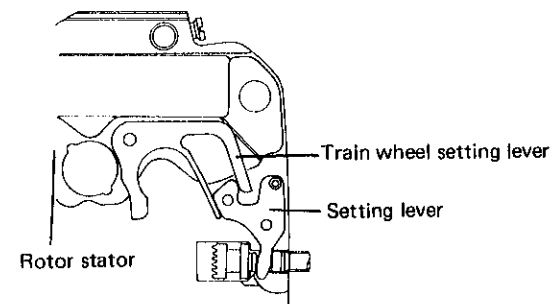

Note:
If the train wheel setting lever gets deformed and causes a clearance between the train wheel setting lever and the setting lever, replace the train wheel setting lever with a new one.

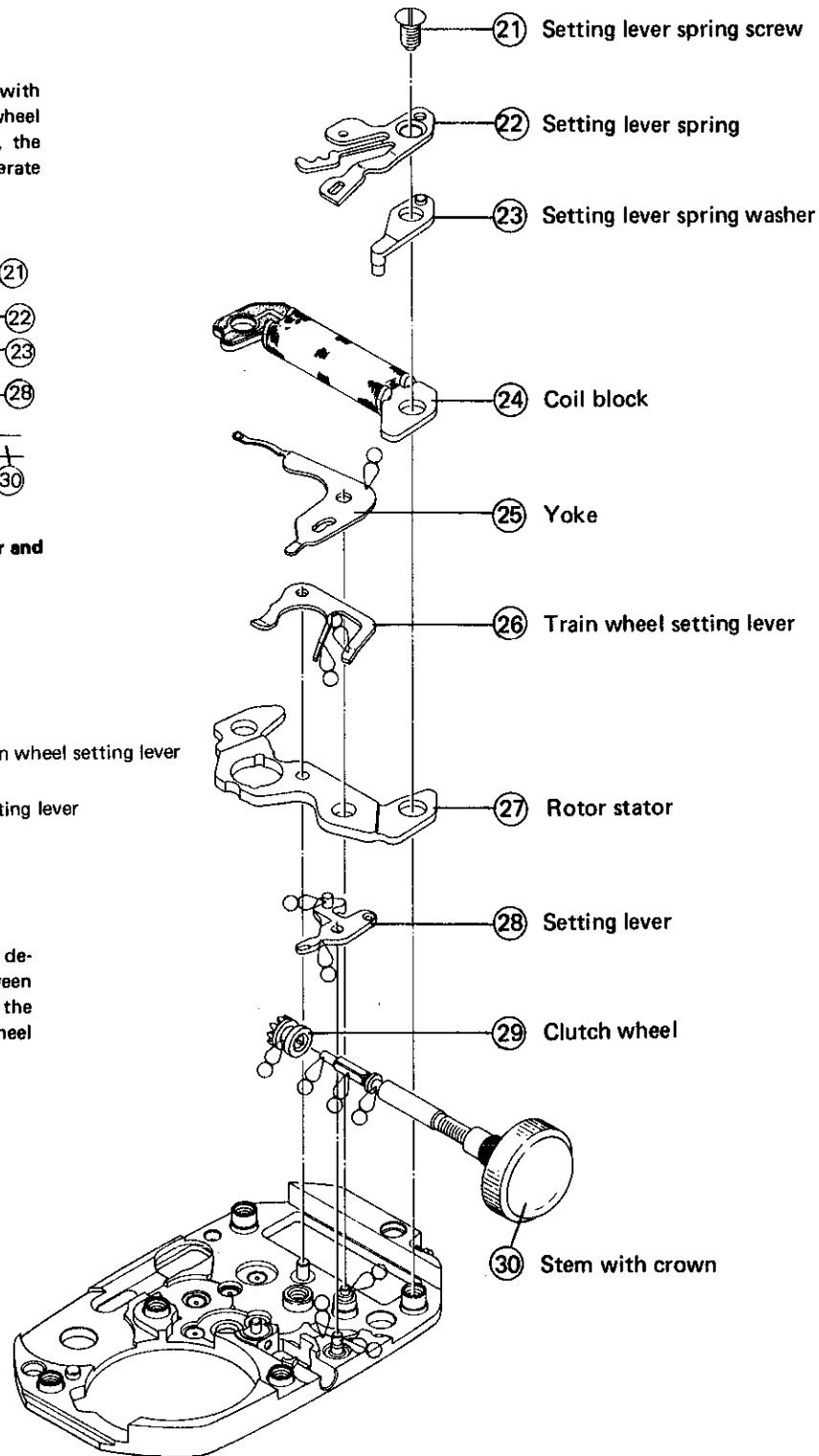

IV. CHECKING AND ADJUSTMENT

- The explanation here is only for the particular points of Cal. 2F50A.
Refer to the "TECHNICAL GUIDE, GENERAL INSTRUCTION" for SEIKO Analogue Quartz for details.

Procedure	
CHECK OUTPUT SIGNAL	<p>Use the quartz tester. Range to be used: 10-second gate (The minute hand moves at 20-second intervals, but the pulse is generated every 10 seconds for measuring the daily rate.)</p> <p>Result: Normal : Input indicator blinks every 10 seconds. Defective : Input indicator does not blink every 10 seconds.</p>
CHECK HANDS SETTING CONDITION	
CHECK BATTERY VOLTAGE	<p>Use the Digital Multi-Tester S-840. Mode to be used: DC V</p> <p>Result: Normal : More than 1.57V Defective : Less than 1.57V</p> <ul style="list-style-type: none"> Before starting measurement, short-circuit the probes to see that the Digital Multi-Tester displays "AUTO 00.0mV" or "AUTO 00.1mV".
CHECK BATTERY CONDUCTIVITY	
CHECK CONDUCTIVITY OF CIRCUIT BLOCK	
CHECK COIL BLOCK	<p>Use the Digital Multi-Tester S-840. Mode to be used: Ω</p> <p>Result: Normal : $2.0K\Omega \sim 2.4K\Omega$ Defective — $\left\{ \begin{array}{l} \text{Less than } 2.0K\Omega \\ \text{(Short circuit)} \\ \text{More than } 2.4K\Omega \\ \text{(Broken wire)} \end{array} \right.$ Replace the coil block with a new one.</p> <ul style="list-style-type: none"> Before starting measurement, short-circuit the probes to see that the Digital Multi-Tester displays "AUTO 00.2 ~ 00.4Ω" with the buzzer beeping.

Procedure

CHECK GEAR TRAIN MECHANISM

CHECK RESET AND TRAIN WHEEL SETTING CONDITION

(1) Check to see if the step rotor stops promptly when the crown is pulled out completely and if it starts exactly 20 seconds after the crown is pushed in back to the normal position.

(2) Check train wheel setting condition.
Check the clearance between the train wheel setting lever and the fifth wheel and pinion by looking through the hole of the train wheel bridge.

• With the crown at the normal position

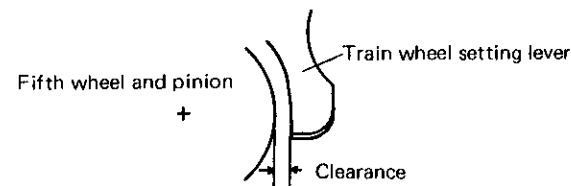

Result:
Normal : Clearance
Defective : No clearance
Replace the train wheel setting lever with a new one.

• With the crown at the first click position

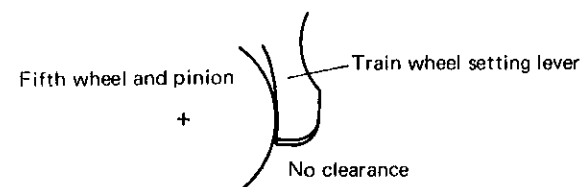

Result:
Normal : No clearance
Defective : Clearance
Replace the train wheel setting lever with a new one.

(3) Check reset condition.
Check output signal of the circuit block with the coil block and battery installed.

• With the crown at the normal position

Result:
Normal : Input indicator blinks every second.
Defective : Input indicator does not blink every second.
Replace the yoke with a new one.

• With the crown at the first click position

Result:
Normal : Input indicator does not blink every second.
Defective : Input indicator blinks every second.
Replace the yoke with a new one.

Procedure

CHECK CURRENT CONSUMPTION

Caution:

- Do not check current consumption under an incandescent lamp since strong light may cause a watch to consume excess current.
- Be sure to protect the MOS-IC unit from light with a black paper while measuring.

Use the Digital Multi-Tester S-840.
Mode to be used: μA

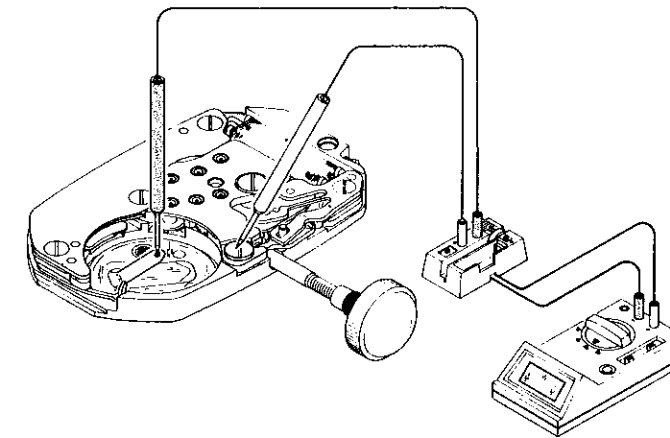

Probe red Circuit block cover
Probe black Battery connection (-)

Result:
Normal : Less than $0.3\mu A$
Defective : More than $0.3\mu A$

- (1) Set the display stabilizing switch of the tester to the "B" position.
- (2) Apply the (+) and (-) probes of the tester as shown in the illustration above, and the tester displays a value, indicating that electric current is flowing in the IC.
- (3) The value displayed is increased, since the current for driving the step rotor flows once every 20 seconds.
- (4) After approximately one minute, read a maximum value which is displayed stably.

CHECK ACCURACY

- Use the 10-second gate of the quartz tester.
The minute hand moves at 20-second intervals, but the pulse is generated every 10 seconds for measuring the daily rate.
- If there is time loss/gain, replace the circuit block with a new one.

CHECK APPEARANCE AND FUNCTIONING

All procedures of Disassembling, Reassembling, Lubricating, Checking and Adjustment are completed.