

TECHNICAL GUIDE

AND PARTS LIST

CAL. Y723A

DIGITAL QUARTZ

CONTENTS

I. SPECIFICATIONS.....	1
II. DISASSEMBLING, REASSEMBLING AND LUBRICATING.....	2
1. Disassembling and reassembling and lubricating of the case.....	2
2. Disassembling and reassembling of the module.....	5
III. CHECKING AND ADJUSTMENT.....	7
1. Guide table for checking and adjustment.....	7
2. Relationship between the segment (Liquid Crystal Panel Electrode) and the C-MOS-LSI output terminal.....	8
3. Procedures for checking and adjustment.....	9
A: Check battery voltage.....	9
• How to check battery electrolyte leakage and repair.....	9
B: Check contact of C-MOS-LSI ~ liquid crystal panel.....	10
C: Check liquid crystal panel and circuit block.....	10
D: Check current consumption.....	12
E: Check accuracy.....	13
F: Check functioning and adjustment.....	13
G: Check bulb condition.....	13
• How to replace the bulb.....	14
H: Check conductivity of switch components.....	15
IV. PARTS LIST OF MODULE.....	16

I. SPECIFICATIONS

Item	Cal. No.	Y723A
Display medium		Nematic Liquid Crystal, FEM (Field Effect Mode)
Display system		Three-function changeover system with time, time/calendar and calendar functions. <ul style="list-style-type: none"> ● Time function: Digital display system showing hour, minute, second and day of the week (PM indication) ● Time/calendar function: Digital display system showing hour, minute, date and day of the week (PM indication). Dot flashes per second. ● Calendar function: Digital display system showing month, date, year and day of the week. <ul style="list-style-type: none"> • 200-year calendar from 1900 - 2099 • Automatic month end and leap year adjuster. * In each function, pressing the button enables the time or calendar correction.
Additional mechanism		Illuminating light
Crystal oscillator		32.768 Hz (Hz = Hertz..... Cycles per second)
Loss/gain		Loss/gain at normal temperature Monthly rate: less than 20 seconds (Annual rate: less than 4 minutes)
Casing diameter		φ28.1 mm
Height		4.2 mm
Operational temperature range		-10°C ~ +60°C (14°F ~ 140°F)
Regulation system		Trimmer condenser
Battery power		Silver oxide battery: U.C.C. 392, Sony Eveready 392, Maxell SR41W Battery life: Approx. 1 year Voltage: 1.55V
IC (Integrated Circuit)		C-MOS-LSI 1 unit

II. DISASSEMBLING, REASSEMBLING AND LUBRICATING

1. Disassembling and reassembling and lubricating of the case

Disassembling procedures Figs.: ① ~ ⑤

Reassembling procedures Figs.: ⑤ ~ ①

Lubricating:
Silicone grease (500,000 c.s.)
Normal quantity ●

Glass portion.

It is not necessary to disassemble the glass except when it is replaced. (See page 4 for handling.)

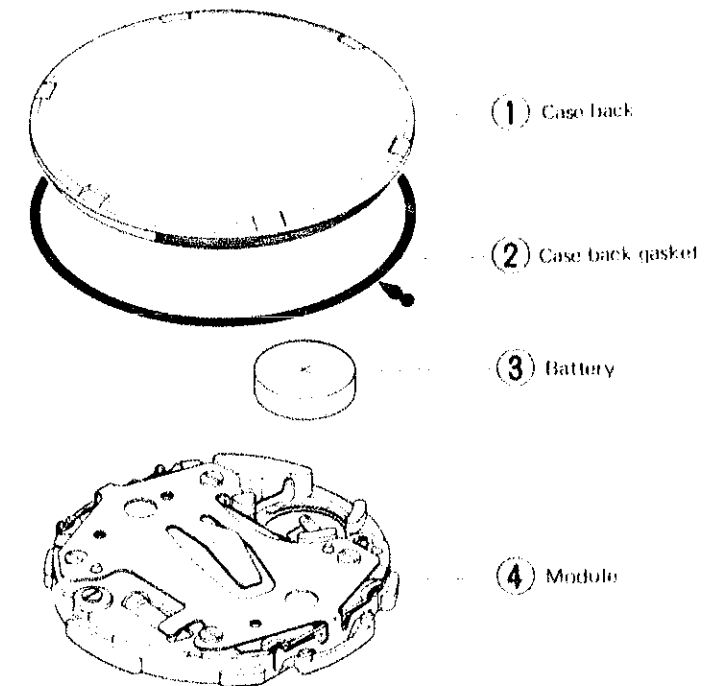
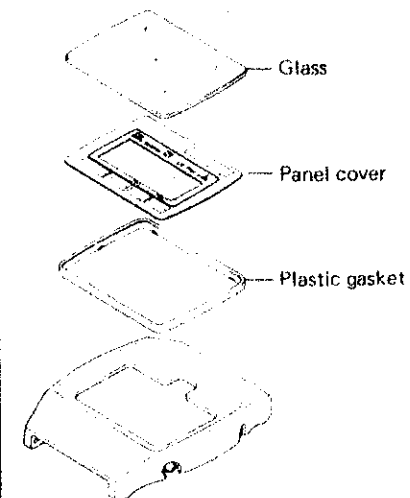

(Time adjusting buttons)

It is not necessary to disassemble the time adjusting buttons (3 assemblies) except when they are required to be replaced.

Cut for the module positioning

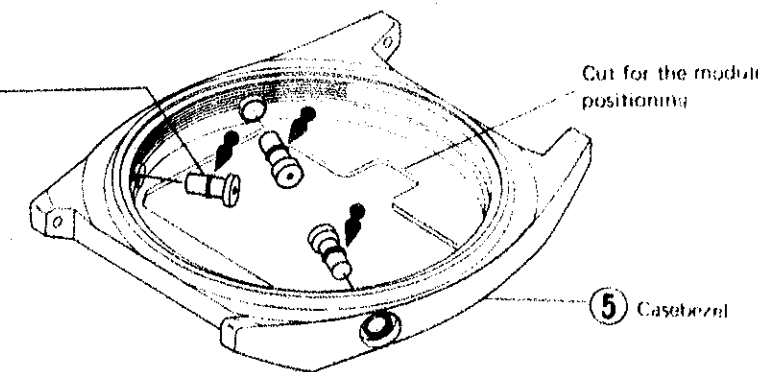

Remarks for disassembling

(4) Module

- Put the tips of the tweezers in a clearance between the liquid crystal panel and the casebezel and pry up the module to take out.

Remarks for reassembling

(5) Casebezel

- Before reassembling the module, pull out all buttons so that the switch springs do not prevent the module from being reassembled. (Push the buttons from inside with the tips of tweezers.)

(4) Module

- As the liquid crystal panel frame is fixed fast to the casebezel, push in the module with fingers.
- Push it in so that it does not catch the buttons.

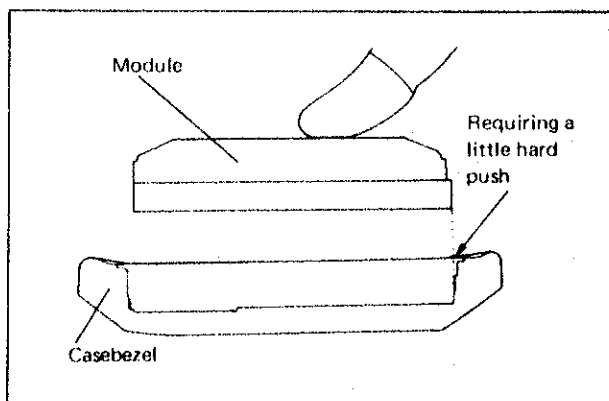
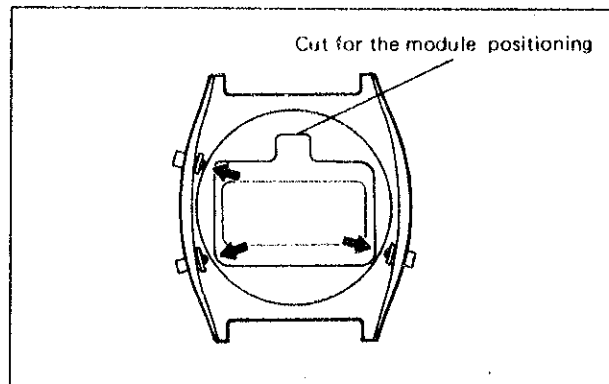
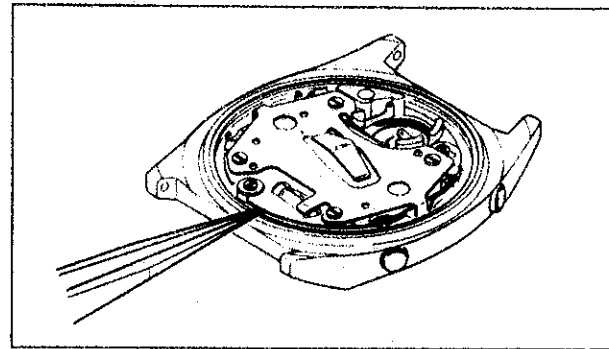

How to replace the glass

(It is not necessary to disassemble the glass except when the glass and the panel cover are replaced.)

How to disassemble the glass

- Remove the glass.
 - Inserting disk
 - Supporting disk: $\phi 34.0 \sim \phi 35.0$ mm
- Place a vinyl sheet between the glass and the supporting disk as shown in the illustration on the right.
- Push only the glass for disassembling with the inserting disk. Do not push the panel cover.

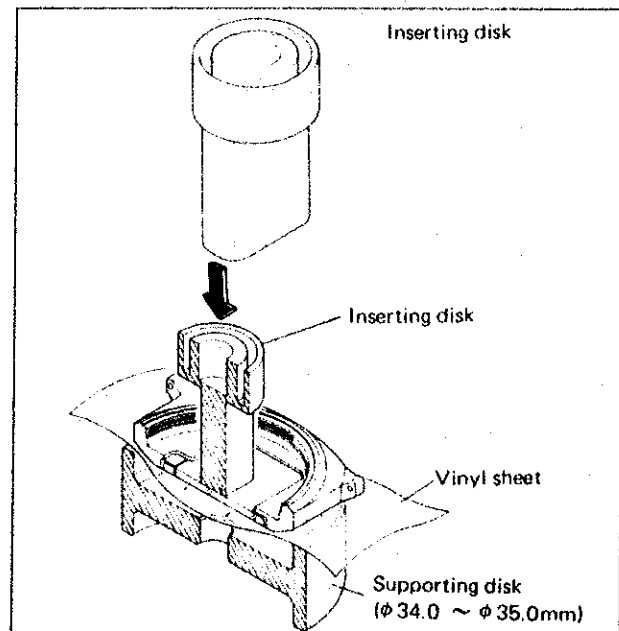

How to reassemble the glass

- Set the plastic gasket.
 - There are two different type gaskets, pay attention to their installation sequence.
 - I-shaped plastic gasket
 - Install in the casebezel.

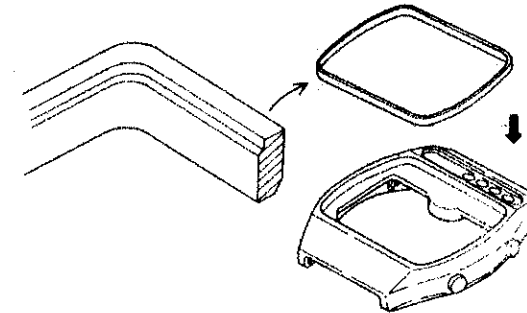

- L-shaped plastic gasket
 - Attach to the glass and insert into the casebezel.

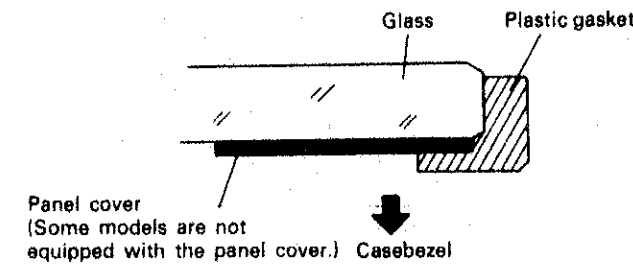

(ii) Reassemble the panel cover.

- Be sure to set the backside of the panel cover fast to the casebezel.
 - Be sure that the space between the casebezel and the edge of the panel cover is uniform in width.
- (iii) Place the glass.**
- Be careful not to mistake the upper side for the lower side. Place the round side down.

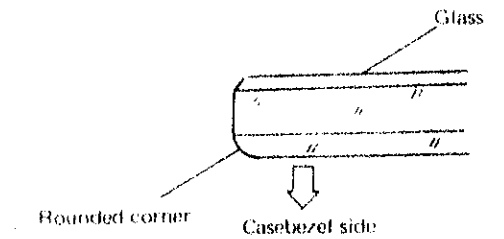

(iv) Push in the glass.

Inserting disk: Plastic inserting disk
Supporting disk: $\phi 30.5$ or $\phi 31.0$ mm

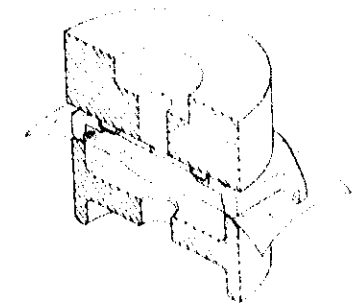

3. Cleaning

Name of parts	Cleaning	Drying	Solution	Remarks
Connector	Rinse or wash with a soft brush.	Warm air	Alcohol	● Never use benzene or trichloroethylene as these will dissolve the parts.
Plastic parts ● Panel frame	Rinse or wash with a soft brush.	Warm air	Benzene, alcohol	
Other parts (excluding parts that must not be cleaned.)	Rinse or wash with a cleaner or wash with a soft brush.	Warm or hot air	Benzene, alcohol or trichloroethylene	

Parts that must not be cleaned

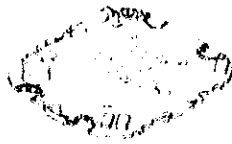

Circuit block

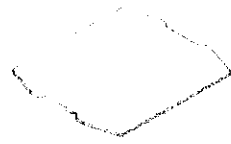

Reflecting mirror



Liquid crystal panel

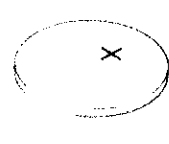

Battery

- Only the conductive portions (liquid crystal panel and circuit block etc.) should be wiped with a cloth moistened with benzene, alcohol, and dried with warm air.

Cleaning

Be sure to clean the parts in a well-ventilated room.

Do not leave the cleaning solution container uncapped for any length of time in a poorly ventilated room.

The vapor of the cleaning solution is slightly toxic.

Prolonged inhalation of the vapor may induce drowsiness and provoke nausea, headache or dizziness.

III. CHECKING AND ADJUSTMENT

Be sure to use the Static electricity protector when handling the module.

1. Guide table for checking and adjustment

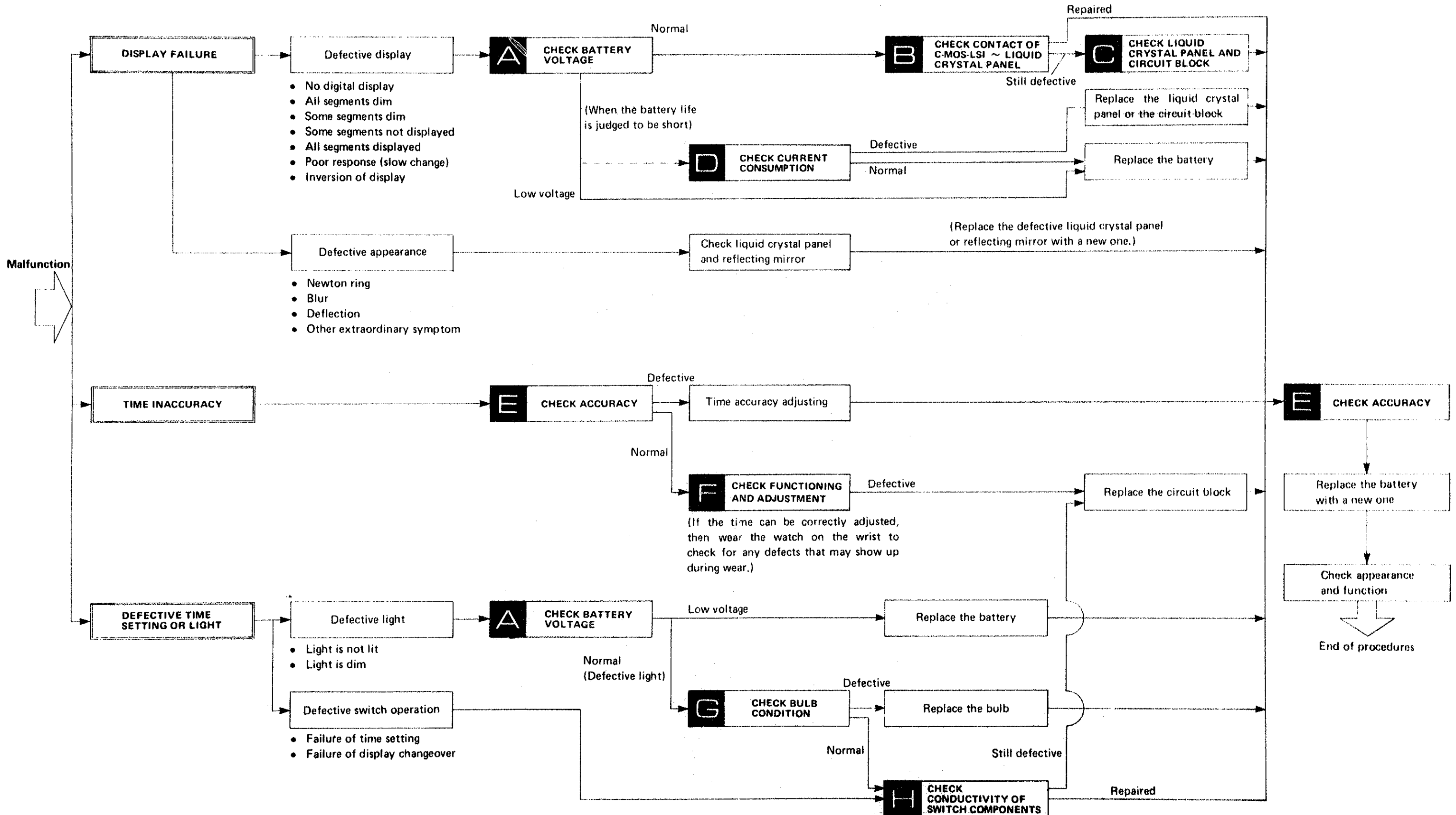

2. Relationship between the segment (Liquid Crystal Panel Electrode) and the C-MOS-LSI output terminal

A complete knowledge of how the segment (Liquid Crystal Panel Electrode) works with the C-MOS-LSI output terminal will provide the proper procedures for checking and adjustment.

• Designation of segment

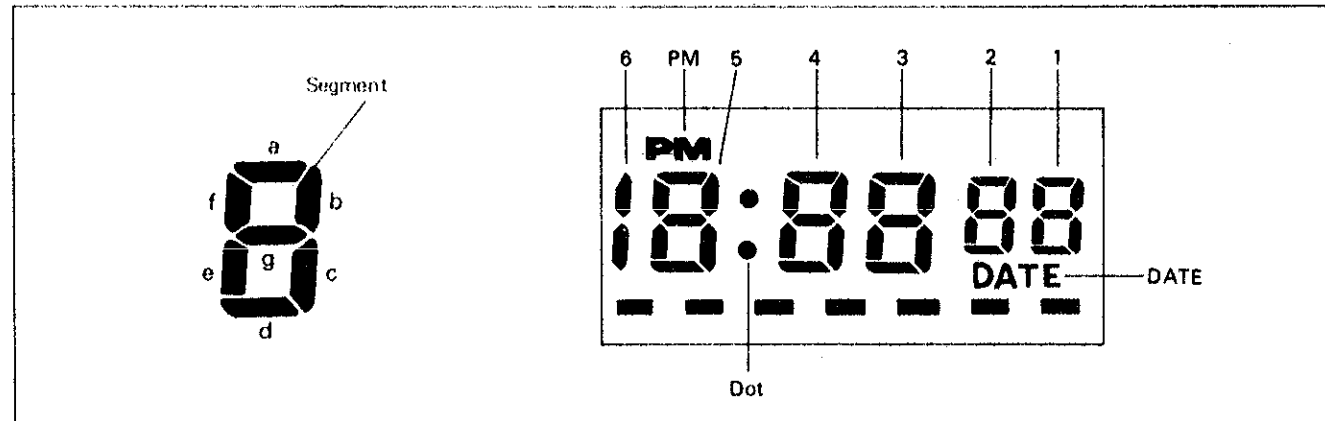

• Relationship between the segment and the C-MOS-LSI output terminal

The liquid crystal panel electrode is connected electrically with each segment which forms a digital figure as shown in the illustration of the panel pattern below.

(The panel pattern can be seen if the panel is slightly tilted and looked at in an angular position.) Also, the liquid crystal panel electrode is connected electrically with the C-MOS-LSI output terminal by the connector.

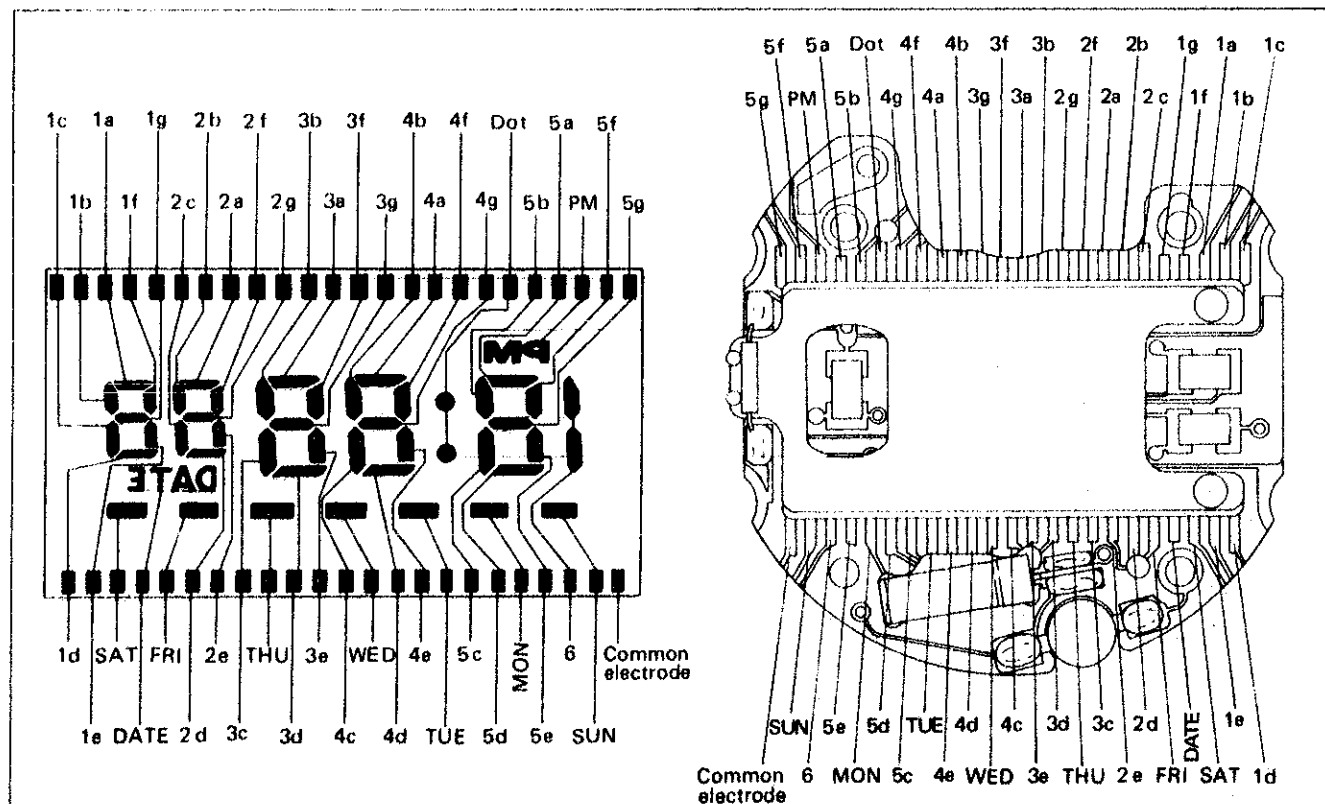

Note: Poor conductivity of the common electrode causes the lighting of all segments or inversion of the display.

3. Procedures for checking and adjustment

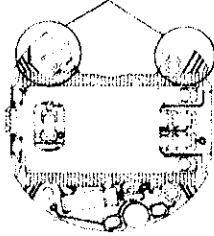
	Procedures	Result and repair
CHECK BATTERY VOLTAGE	<p>Check battery voltage.</p> <div style="border: 1px solid black; padding: 5px; margin: 10px 0;"> <p>When there is battery electrolyte leakage, refer to "HOW TO CHECK BATTERY ELECTROLYTE LEAKAGE AND REPAIR" below for repairing.</p> </div>	<p>More than 1.5V ... Normal Less than 1.5V ... Defective</p>
HOW TO CHECK BATTERY ELECTROLYTE LEAKAGE AND REPAIR	<ol style="list-style-type: none"> (1) Remove the module from the case. (2) Disassemble the module. (3) Wipe off battery electrolyte on the circuit block. <ol style="list-style-type: none"> 1. Wipe off battery electrolyte with a cloth moistened with distilled water. (If distilled water is not available, use tap water.) <div style="border: 1px solid black; padding: 5px; margin: 10px 0;"> <p>Note:</p> <ul style="list-style-type: none"> • Do not expose the trimmer condenser to water or alcohol, and if it is exposed, there may be a change in the condenser capacity and eventually in the time accuracy. • Do not use a cloth which gives off lint, such as gauze, flannel, etc. </div> <p>○ When the circuit block is cleaned, be sure to clean the connecting portions.</p> <div style="text-align: center;">  </div> <p>If the circuit block is badly contaminated with battery electrolyte, replace the battery connection, circuit block or switch spring with a new one. (Example: When the printed circuit of circuit block is rusted.)</p> <ol style="list-style-type: none"> 2. Rinse with alcohol. (If the cleaned portions remain wet with water, they will corrode with rust.) 3. Dry with warm air by using a dryer. <ol style="list-style-type: none"> (4) Clean the other parts (switch spring, liquid crystal panel frame, battery connection, etc.) <ol style="list-style-type: none"> 1. Wipe off battery electrolyte on each part with a soft brush moistened with distilled water. (If distilled water is not available, use tap water.) 2. Rinse with alcohol. 3. Dry with warm air by using a dryer. <ol style="list-style-type: none"> (5) Reassemble the module. Replace the battery with a new one. (6) Check to see if the time and calendar function, the stopwatch function, the calendar function and the current consumption are normal. 	

Procedures

After removing the liquid crystal panel, check for poor conductivity of the liquid crystal panel, connector and C-MOS-LSI output terminal. (Refer to the "Relationship between the segment and the C-MOS-LSI output terminal" on page 8.) Use a microscope for checking.

- (1) Check for dust, lint and other contamination on the connector and liquid crystal panel electrode.

Be sure to check the connecting portion of the liquid crystal panel and the circuit block (A) carefully.

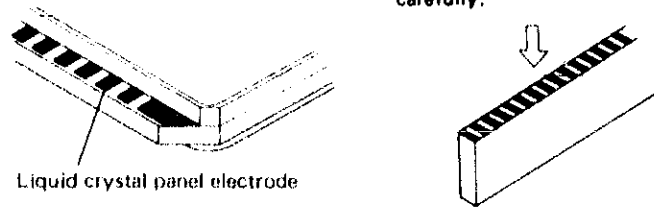

- (2) Check for any scratches, cracks and breaks of the connector and the liquid crystal panel.

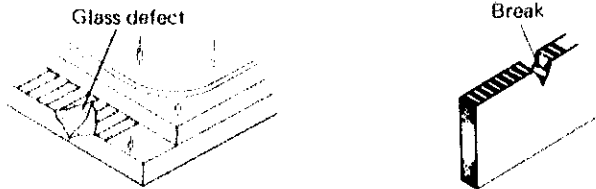

- (3) Check for dust, lint and other contamination on the output terminal of the circuit block.

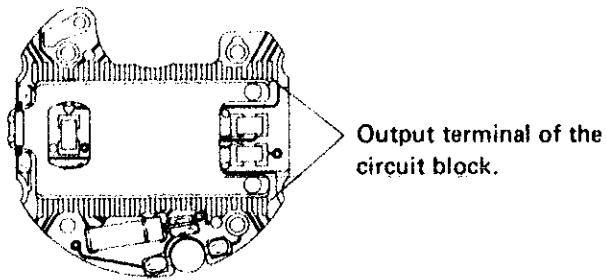

Result and repair

Uncontaminated: Normal
Proceed to (2).
Contaminated: Defective
Wipe off any foreign matter.

No contamination, scratches, cracks, or breaks: Normal
Proceed to (3).
Scratched, cracked or broken: Defective
Replace the connector or liquid crystal panel with a new one.

Uncontaminated: Normal
Proceed to (3).
Contaminated: Defective
Wipe off any foreign matter.

Check to see if the liquid crystal panel and the circuit block function correctly. (Refer to the "Relationship between the segment and the C-MOS-LSI output terminal" on page 8.)

- (1) Check liquid crystal panel.
 1. Set up the volt-ohm-meter.
Range to be used: OHMS R x 1 ~ R x 1K

Procedures

Note:
Any range will do if more than 3V is applied to the probes of the volt-ohm-meter. If less than 3V is applied to the probes, all segments may not be lit. Change the range to the one (R x 10K) which is higher in resistance than R x 1K.

2. Remove the liquid crystal panel from the module and turn it upside down.
3. Measuring (Check to see if the corresponding segment lights up.)

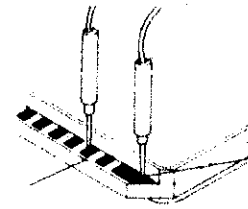

Note: Either red or black probe will do.

Common electrode (Either red or black probe must be applied to the common electrode.)

Electrode of defective segment

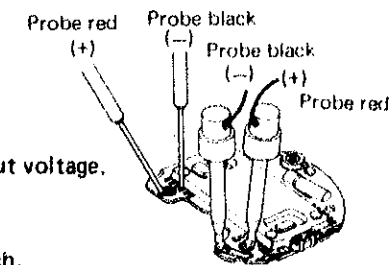
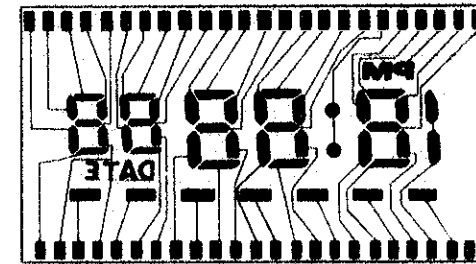

- (2) Check the circuit block output voltage.
 1. Set up the volt-ohm-meter.
Range to be used: DC 3V
 2. Place the module on the bench.
Attach the current supplier to the circuit block.
Clip (+): Connecting portion of the circuit block screw shown in the illustration
Clip (-): Connecting portion of the battery connection
 3. Measuring
Probe Red (+): Connecting portion of the circuit block screw of the circuit block shown in the illustration.
Probe Black (-): Each portion of the output terminal of the C-MOS-LSI

Result and repair

Lights up: Normal
Proceed to (2).
Does not light up or more than two segments light up: Defective
Replace the liquid crystal panel with a new one.

More than 0.8V: Normal
Return to (1).
Less than 0.8V: Defective
Replace the circuit block with a new one.

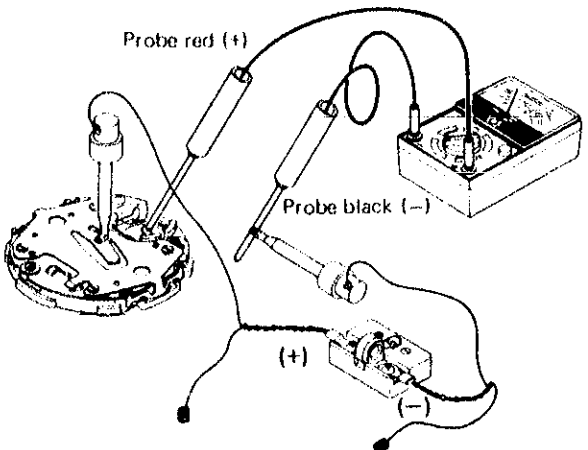
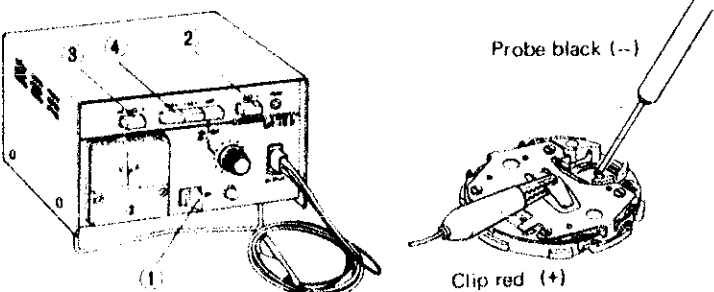
	Procedures	Result and repair
D	<p>(1) Check to see if the current consumption is normal. (Can be checked no matter which function the watch may be performing.)</p> <p>● Set up the volt-ohm-meter. Range to be used: DC12 μA (DC 0.03 mA)* Use the current supplier and connect as shown in the illustration below</p>  <p>Probe red (+) Probe black (-)</p>	<p>*Note: If the pointer of the volt-ohm-meter swings over the maximum value when DC 12 μA (DC 0.03mA) is used, change the range to a greater one where the pointer does not run over the maximum value while applying the probes to the respective portions. Then, after two or three seconds, return the range to DC 12 μA (DC 0.03mA) again for measuring.</p> <p>Less than 2.5 μA: Normal Replace the battery with a new one.</p> <p>More than 2.5 μA: Defective Proceed to (2).</p>
	<p>● Micro Test*</p> <ol style="list-style-type: none"> 1. Power switch... ON 2. Polarity changeover button: + 3. Current consumption/ Voltage indication button: μA 4. Voltage selection button: 1.55V <p>Probe Black (-): Battery connection Clip Red (+): Switch spring</p>  <p>Probe black (-) Clip red (+)</p>	<p>*Note: If the pointer of the Micro Test swings over the maximum value while the current consumption is measured, depress the Current consumption/Voltage indication button (3) so that it is released to indicate the voltage (1.5V) while the black probe and the red clip are applied. Then, after two or three seconds, depress the Current consumption/Voltage indication button again so that it holds in the pushed in position (μA-) to indicate the current consumption for measuring.</p>

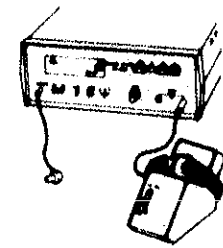
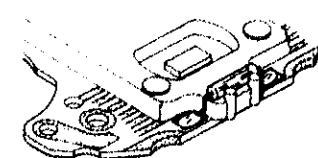
	Procedures	Result and repair
CHECK CURRENT CONSUMPTION	<p>(2) Disassemble the liquid crystal panel, and check to see if the current consumption is normal.</p> <p>Follow the procedures in (1).</p>	<p>Normal: Replace the liquid crystal panel with a new one. Defective: Replace the circuit block with a new one.</p>
CHECK ACCURACY	<p>Check gain and loss of time.</p> <ol style="list-style-type: none"> 1. Set up the Quartz Tester. 2. Measuring 	<p>Does not lose or gain: Normal Proceed to the following procedure. Loses or gains: Defective Proceed to <u>Time accuracy adjusting</u>. Time accuracy is adjusted by turning the trimmer condenser.</p>
CHECK FUNCTIONING AND ADJUSTMENT	<p>Check to see if the watch functions correctly and can be adjusted by the button operation.</p> <p>Check the time and calendar setting function.</p> <ul style="list-style-type: none"> ● Rotate the time and calendar digits more than one cycle for each unit and check to see if each digit is advancing correctly. 	<p>Functions correctly and can be adjusted: Normal Wear the watch on the wrist to check time accuracy. Does not function correctly or cannot be adjusted: Defective Proceed to <u>Replace the circuit block</u>.</p>
CHECK BULB CONDITION	<p>(1) Check to see if the bulb lead terminals touch the lead terminal of the circuit block.</p> 	<p>No exfoliation of solder: Normal Proceed to (2). Exfoliation of solder: Defective Re-solder the foot of the bulb.</p> <p>Refer to "HOW TO REPLACE THE BULB" on page 14 for re-soldering.</p>

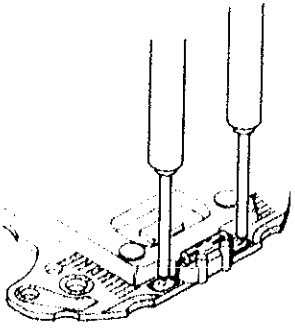
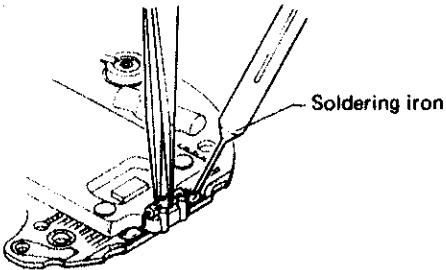
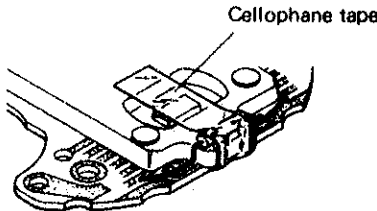
	Procedures	Result and repair
CHECK BULB CONDITION	<p>(2) Check to see if there is a broken filament in the bulb.</p> <ol style="list-style-type: none"> 1. Set up the volt-ohm-meter. Range to be used: OHMS R x 1 2. Measuring Apply the two probes of the volt-ohm-meter to the bulb lead terminal as shown in the illustration.  <p>Note: Either red or black probe will do.</p>	<p>Lights up: Normal Proceed to I.</p> <p>Does not light up: Defective Replace the bulb with a new one.</p> <p>Refer to "HOW TO REPLACE THE BULB" for replacing the bulb with a new one.</p>
HOW TO REPLACE THE BULB	<div style="border: 1px solid black; padding: 5px; margin-bottom: 10px;"> <p>Use the soldering iron with a thin and sharp tip, which has small heat capacity. Thickness of tip: Approx. $\phi 1.0$ mm Heat capacity: Power consumption 5W ~ 20W</p> </div> <ol style="list-style-type: none"> (1) Remove the defective bulb. Hold the defective bulb by tweezers and pull it up slightly. Then, put the tip of the soldering iron on the bulb terminal and remove the bulb.  <ol style="list-style-type: none"> (2) Check to see if the new bulb is normal. Follow the procedures Check bulb condition for checking. (3) Solder the feet of the bulb on the pin side of the circuit board. Be careful not to make the feet slack when soldering. Fix the bulb on the pin side of the circuit board by cellophane tape and it makes it easier to solder the bulb. 	

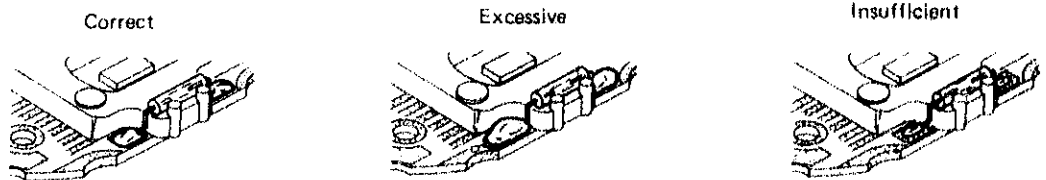
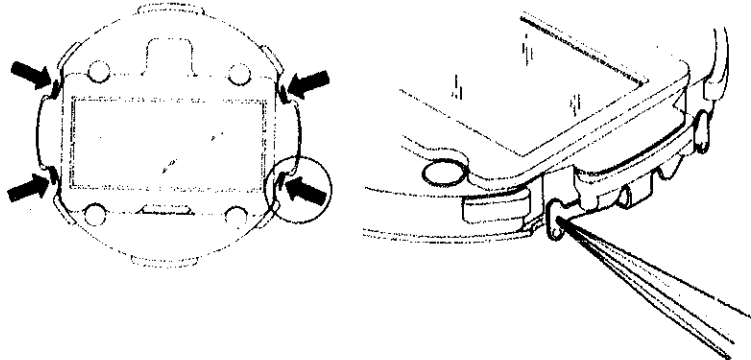
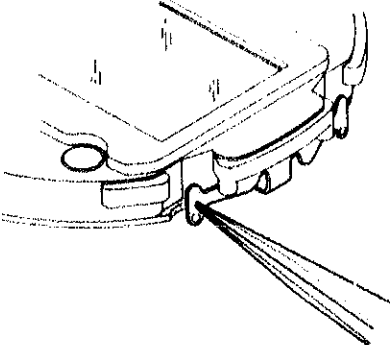
	Procedures	Result and repair
HOW TO REPLACE THE BULB	<ol style="list-style-type: none"> (4) As the foot of the bulb is long, cut it by nippers after it is soldered. <p>Remarks:</p> <ol style="list-style-type: none"> 1 Be careful not to hold the tip of the soldering iron on for a long time or the circuit block may be damaged. Take off the soldering iron from the connecting portion when solder becomes evenly spread on the circuit board. (Approx. 1 second.) 2 Be careful not to touch the reflecting mirror spacer (made of plastic) with the soldering iron.  <ol style="list-style-type: none"> (5) Check the bulb condition again. 	
CHECK CONDUCTIVITY OF SWITCH COMPONENTS	<p>Check to see if the switch spring functions correctly.</p> <ol style="list-style-type: none"> (1) Check to see if the switch springs (four arrow-marked portions shown in the illustration below) function correctly when they are pushed in.  <ol style="list-style-type: none"> 1. Check to see if the four arrow-marked springs touch the switch terminals of the circuit block when they are pushed in with the tips of tweezers and that they do not touch the switch terminals of the circuit block when released.  <ol style="list-style-type: none"> 2. Check for dust, lint and other contamination on the contacting portions. 	<p>Functions correctly: Normal Does not function correctly: Defective</p> <p>If the switch springs do not function correctly after they are adjusted, replace them with new ones.</p> <p>No dust, lint or uncleaned: Normal Proceed to I (2). Dust, lint or contaminated: Defective Wipe off any foreign matter.</p>

All procedures of Disassembling, Reassembling, Checking and Adjustment are completed.

IV. PARTS LIST OF MODULE

Cal. Y723A			
PART NO.	PART NAME	PART NO.	PART NAME
4001 80 ()	Circuit block		
4245 800	Switch spring		
4270 800	Battery connection		
4313 800	Connector		
4398 800	Liquid crystal panel frame		
☆ 4510 800	Liquid crystal panel		
4521 710	Reflecting mirror (Silver)		
4530 849	Bulb		
022 283	Circuit block screw		
☆ SONY EVEREADY 392	Silver oxide battery		
☆ Maxell SR41W			
☆ U.C.C. 392			
☆ Toshiba WG3			

Remarks:

Liquid crystal panel
 ☆ 4510 800 Be sure that the combination between the color of panel and liquid crystal panel should be matched.

Battery
 ☆ SONY EVEREADY 392 }
 ☆ Maxell SR41W } Additional batteries for this calibre might be added as substitutes in
 ☆ U.C.C. 392 } the future.
 ☆ Toshiba WG3 }

☆ ○ Please see remarks.