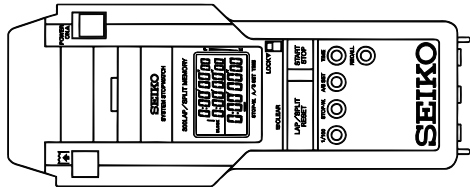

# PARTS CATALOGUE / TECHNICAL GUIDE

## Cal. S149A

### [SPECIFICATIONS]

Item		Cal. No.	S149A
Module		 <p style="text-align: right;">(x 0.30)</p>	
Module size	Outside diameter	198.1 mm between 6 o'clock and 12 o'clock sides 81.6 mm between 3 o'clock and 9 o'clock sides	
	Height	28.5 mm	
Display medium		Nematic Liquid Crystal, FEM (Field Effect Mode)	
Liquid crystal driving system		1/4 multiplex driving system	
Display system		<ul style="list-style-type: none"> <li>• Stopwatch display (Up to 10 hours)               <ul style="list-style-type: none"> <li>• Split time/lap time measurement</li> <li>• Total time measurement</li> </ul> </li> <li>• Time/calendar display</li> <li>• Auto start setting display</li> </ul>	
Additional mechanism		<ul style="list-style-type: none"> <li>• Memory function: Up to 300 measurements</li> <li>• Memory capacity indicator (With warning sound)</li> <li>• Confirmation sound for watch operation</li> <li>• Auto start function</li> <li>• Transfer of auto start time to Cal. S143 or S144</li> <li>• Contrast adjustment function</li> <li>• Battery life indicator</li> <li>• Connection with grip switch</li> <li>• Printout function</li> </ul>	
Accuracy		±0.0006% at normal temperature range (corresponds to a loss/gain (monthly rate) of less than 15 seconds)	
Regulation system		Nil	
Measuring gate by quartz tester		Any gate can be used.	
Printer	Print system	Thermal serial dot printer	
	Print method	One-way printing (from left to right)	
	Print speed	Approx. 1.5 lines/sec. (DC 5.0 V at 25° C)	
	Characters	Numerals, alphabet, +, -, x, ÷, =, ?, !, ., :, ', ', " , /	
Battery for the stopwatch		SEIKO CR2430, Sony CR2430 Battery life is approximately 3 years. (When the stopwatch is used for 3 hours a day or less) Voltage: 3.0 V	
Battery for the printer		IEC R6 / ANSI AA manganese or IEC LR6 / ANSI L40 alkaline manganese dry battery (4 pcs.) Manganese battery: Approx. 10,000 lines can be printed out. Alkaline manganese battery: Approx. 20,000 lines can be printed out. Voltage: 1.5 V x 4 (6.0 V)	

Disassembling procedures Figs. : ① → ③⑤

Reassembling procedures Figs. : ③⑤ → ①

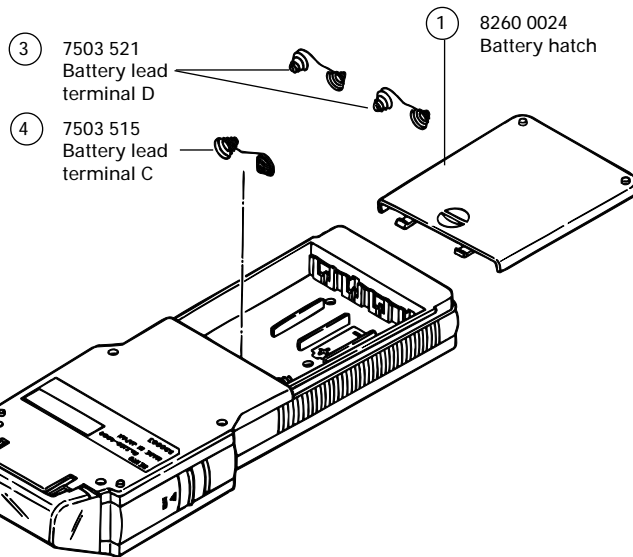
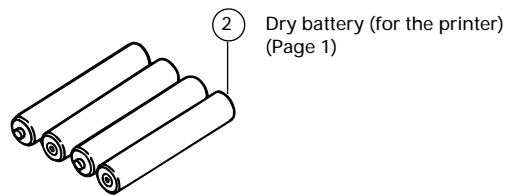
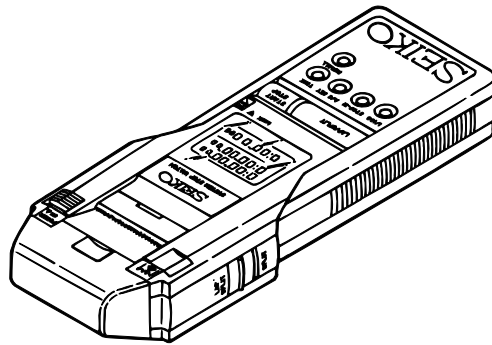

# PARTS CATALOGUE

Cal. S149A

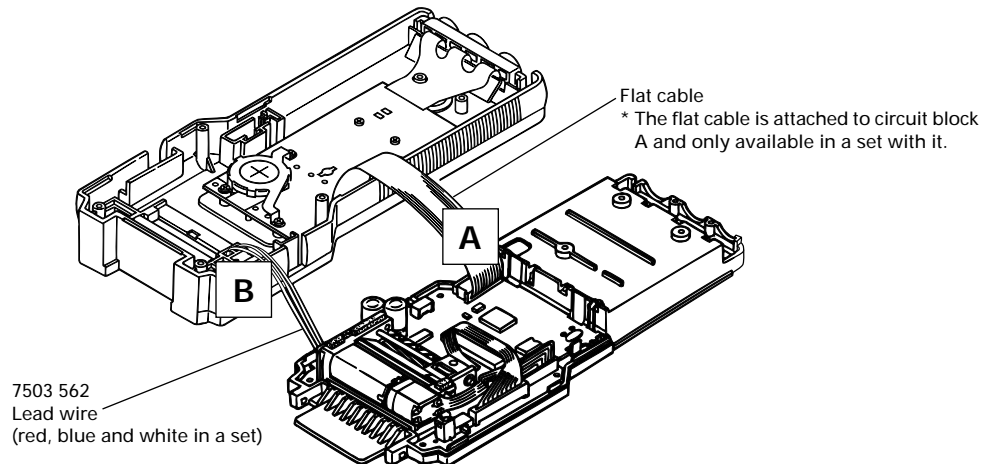
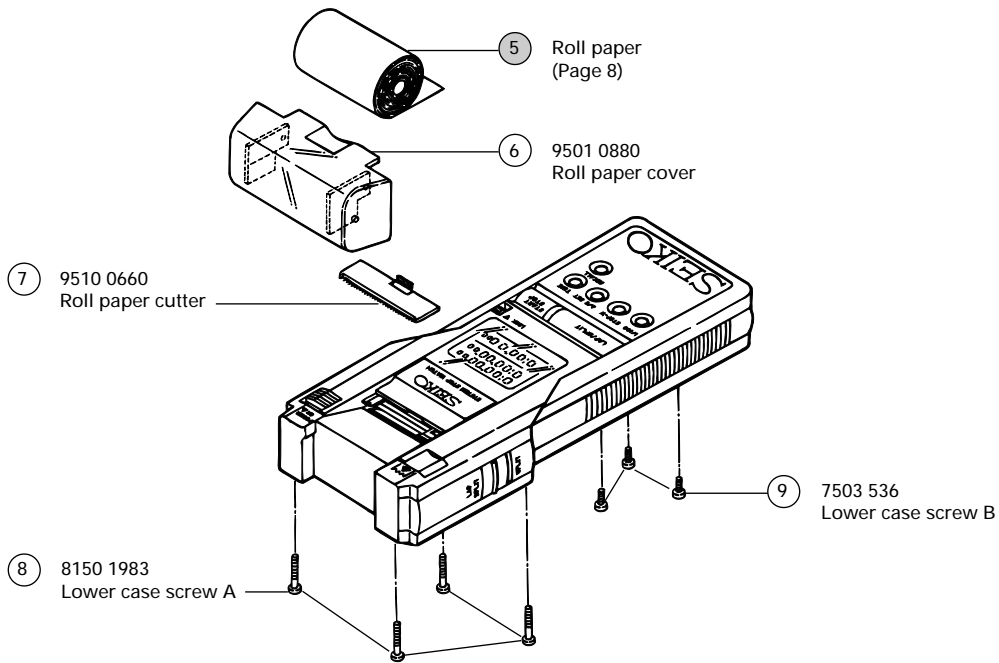

**B** Lead wire

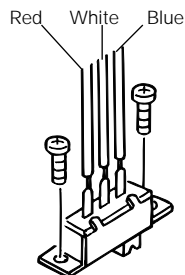

• **How to remove**

- 1) Remove the soldering; or
- 2) After removing the power switch cover, remove the power switch fixing screw.

**A** Flat cable

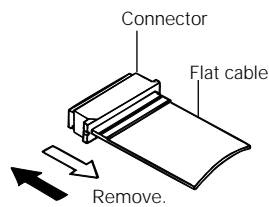

• **How to remove**

Move the connector in the direction of the arrow (⇐) to unlock it.

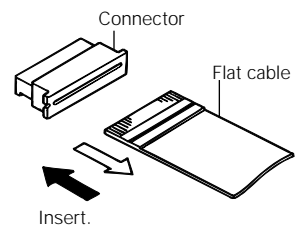

• **How to install**

Insert the flat cable as far as it goes, and move the connector in the direction of the arrow (⇒) to lock it.

● ⇨ Please see the remarks on the page shown after the part name.

# PARTS CATALOGUE

Cal. S149A

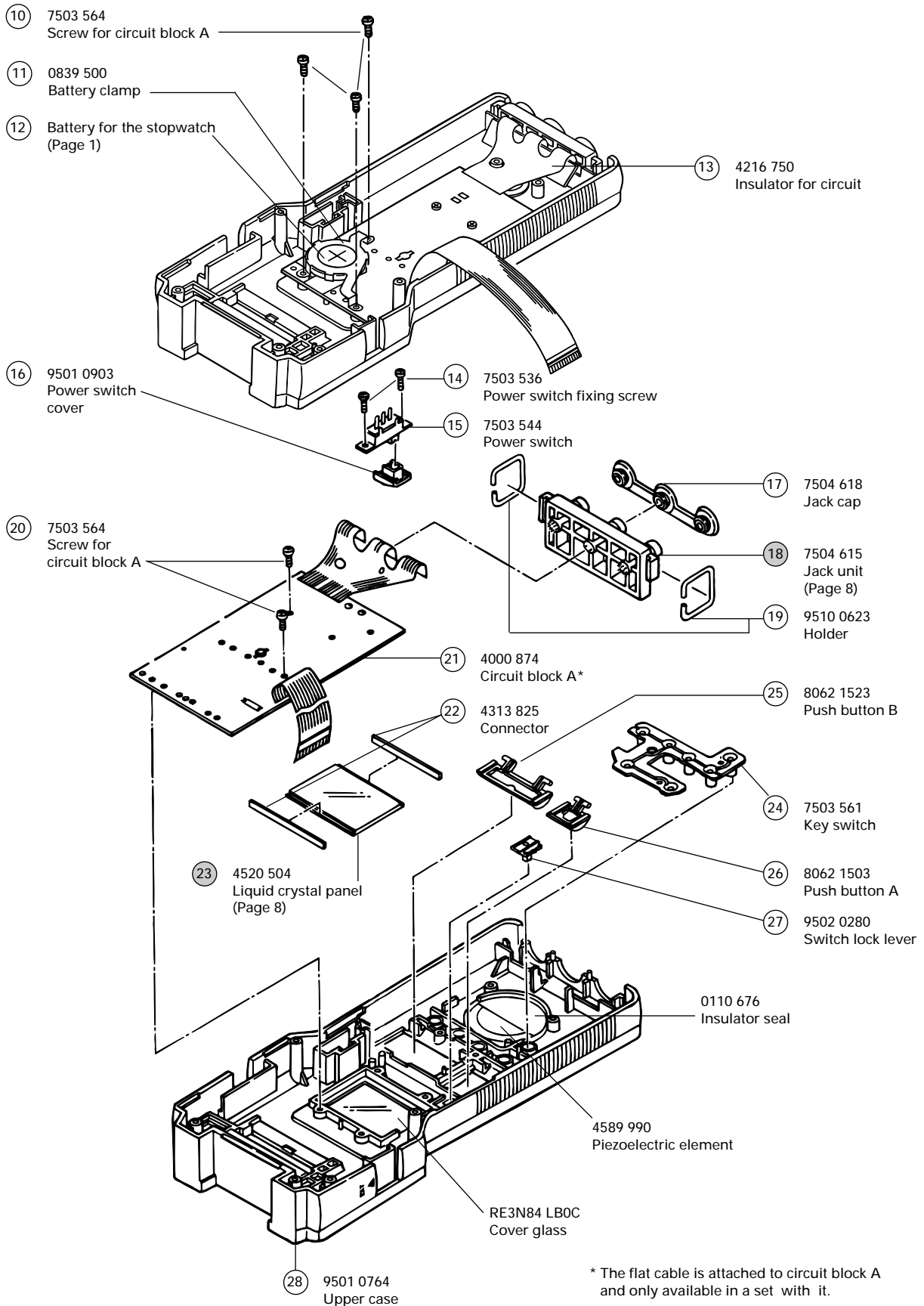

\* The flat cable is attached to circuit block A and only available in a set with it.

➔ Please see the remarks on the page shown after the part name.

# PARTS CATALOGUE

Cal. S149A

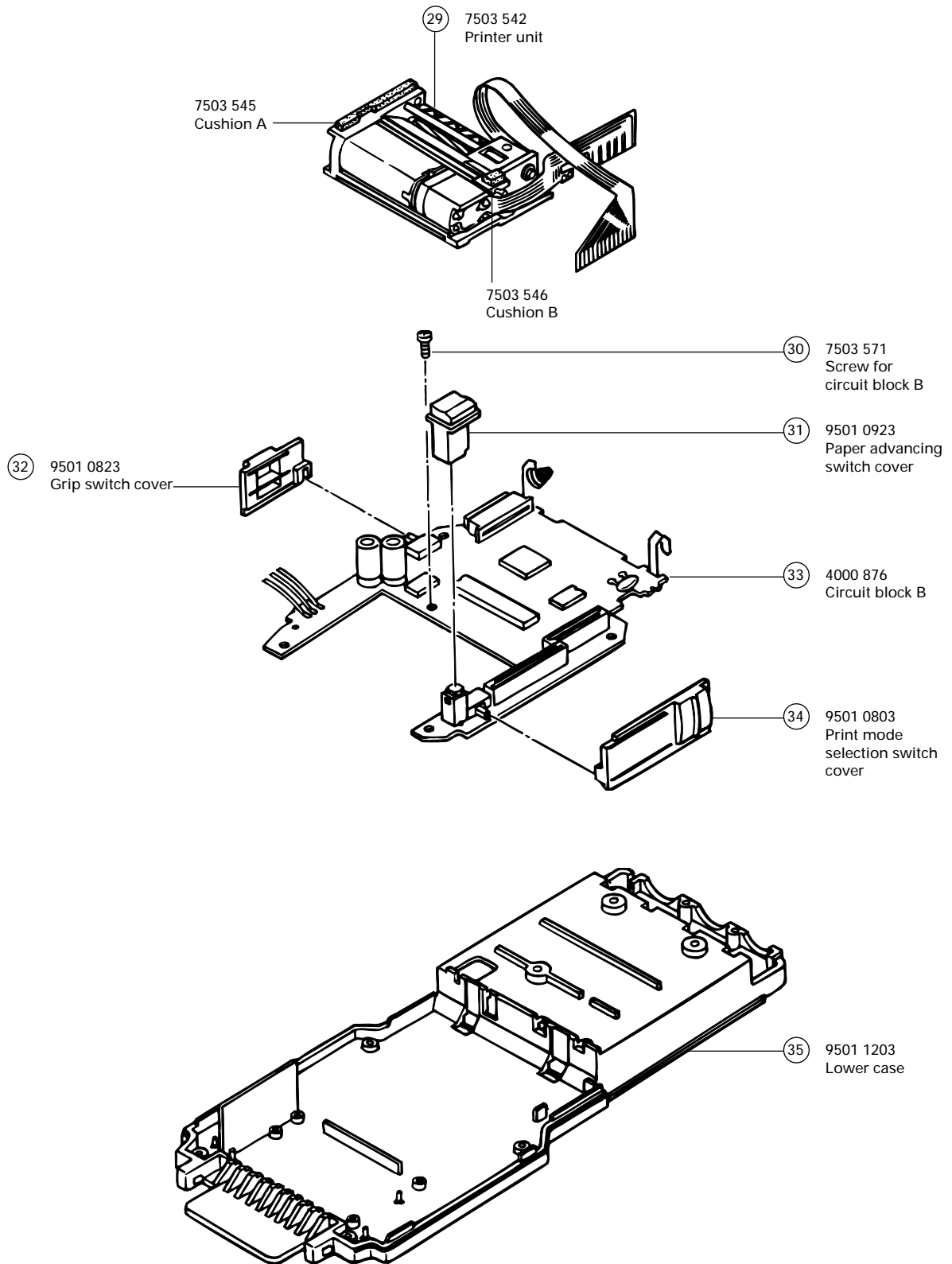

- The explanation here is only for the particular points of Cal. S149A.
- For the repairing, checking and measuring procedures, refer to the "TECHNICAL GUIDE, GENERAL INSTRUCTIONS".

## I. STRUCTURE OF THE CIRCUIT BLOCK

**Circuit block A (for the stopwatch)**

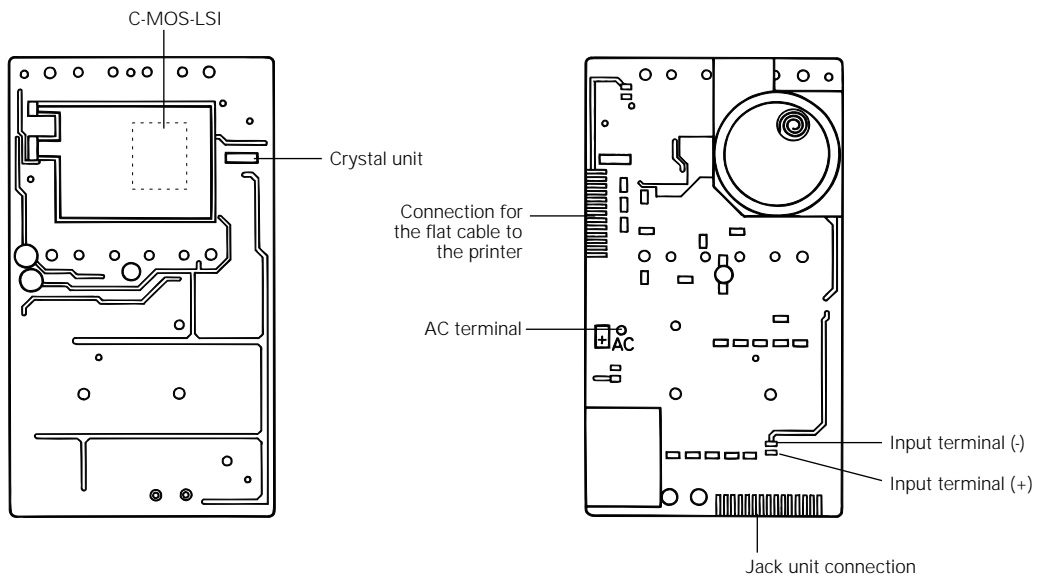

**Circuit block B (for the printer)**

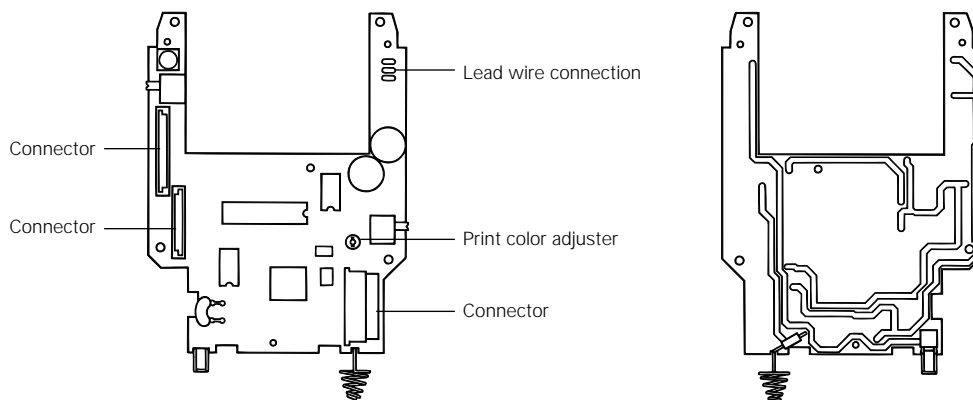

## II. REMARKS ON BATTERY REPLACEMENT

### • How to install the battery

To install the battery, follow the procedure below.

1. Be sure to wear finger cots.
2. Set the battery to the battery clamp as shown in the illustration below. In doing so, be careful not to short-circuit the (+) and (-) terminals of the battery with tweezers or the like.

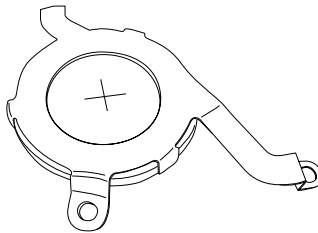

3. Fix the battery clamp to the circuit block with the battery clamp screw as shown in the illustration below.

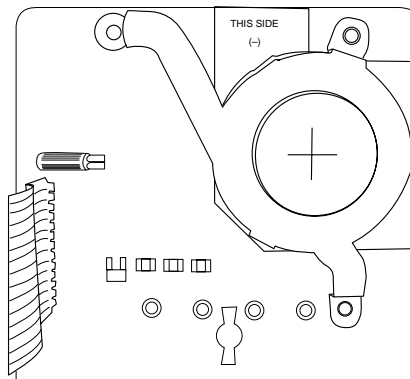

### • Remarks after installing the battery

After the battery is replaced with a new one, or after the battery is re-installed following the repairing procedures, be sure to short-circuit the AC terminal of the circuit block and plus terminal of the circuit block with conductive tweezers for more than 2 seconds as illustrated below to reset the circuit.

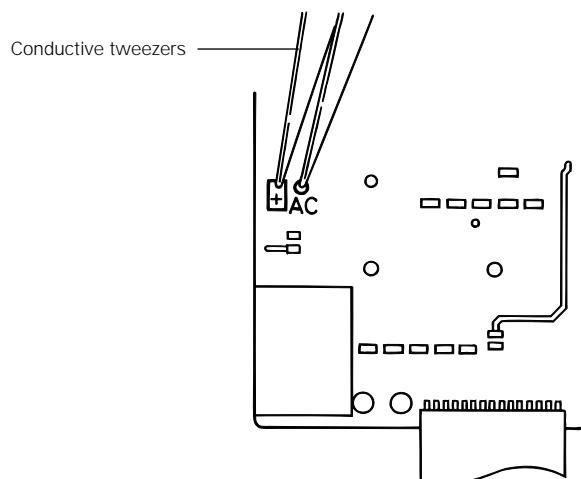

\* When the circuit is reset, "January 1, 2000 0:00'00"" will be shown on the display.

## III. REMARKS ON DISASSEMBLING AND REASSEMBLING

### ⑤ Roll paper

#### • How to remove

Cut out the roll paper in the paper cover, and then, remove the remaining paper by keeping the paper advancing switch pressed.

\* Never pull out the paper from the paper inserting slot.

#### • How to install

Insert the end of the roll paper into the paper inserting slot, and keep the paper advancing switch pressed until the end of the paper is advanced out 2 to 3 cm from the printer.

### ⑱ Jack unit

The jack unit and jack lead terminal are soldered together.

#### • How to remove

Unsolder them with a soldering iron, soak up the melted solder completely with a solder wick or the like, and then, remove the jack lead terminal.

#### • How to install

Set the jack lead terminal to the jack pin, taking care not to set it upside down. Then, re-solder them with the soldering iron.

**Note:** When using the soldering iron, take utmost care not to deform or damage the case and other parts by the heat of the soldering iron.

### ⑳ Liquid crystal panel

#### • How to install

Set the liquid crystal panel as shown in the illustration below.

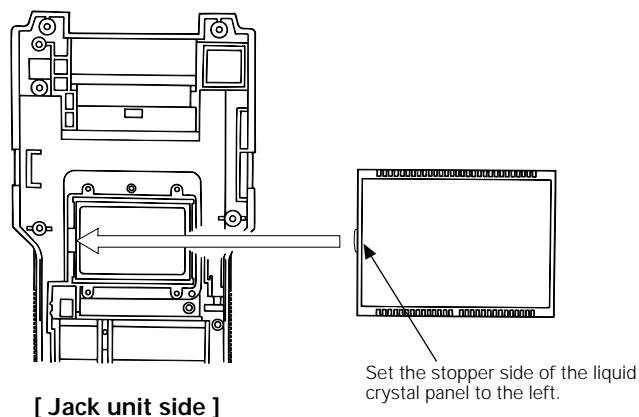



- **Adjustment of the print color**

After the printer unit or circuit block B is replaced with a new one, characters may be printed too lightly or too deeply. In that case, follow the procedure below to adjust the print color.

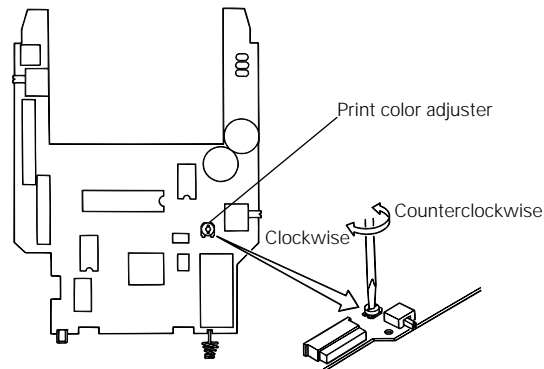

Turn the print color adjuster with a slotted head screwdriver.

- To make the color deep : Turn clockwise.
- To make the color light : Turn counterclockwise.

**Notes:**

1. If the print color is excessively deepened, the current consumption increases and the battery life is shortened.
2. Adjust the print color in the normal temperature (24° C).

## IV. VALUE CHECKING

- **Current consumption**

For the whole module : Less than 14  $\mu$ A

**How to measure the current consumption**

While applying the probe of the tester as shown in the illustration below, measure the current consumption.

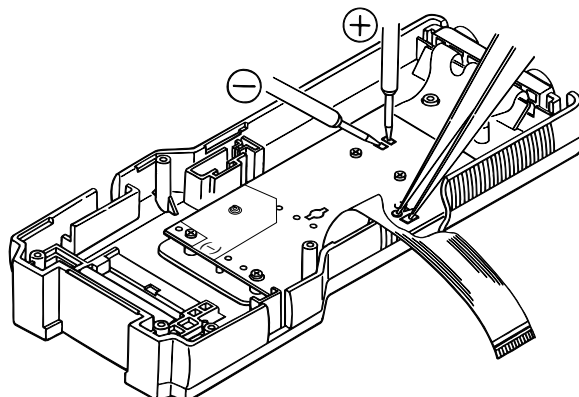

**Note:** Start the measurement 10 seconds after resetting the circuit using the tweezers as illustrated.

• **Parts identification**

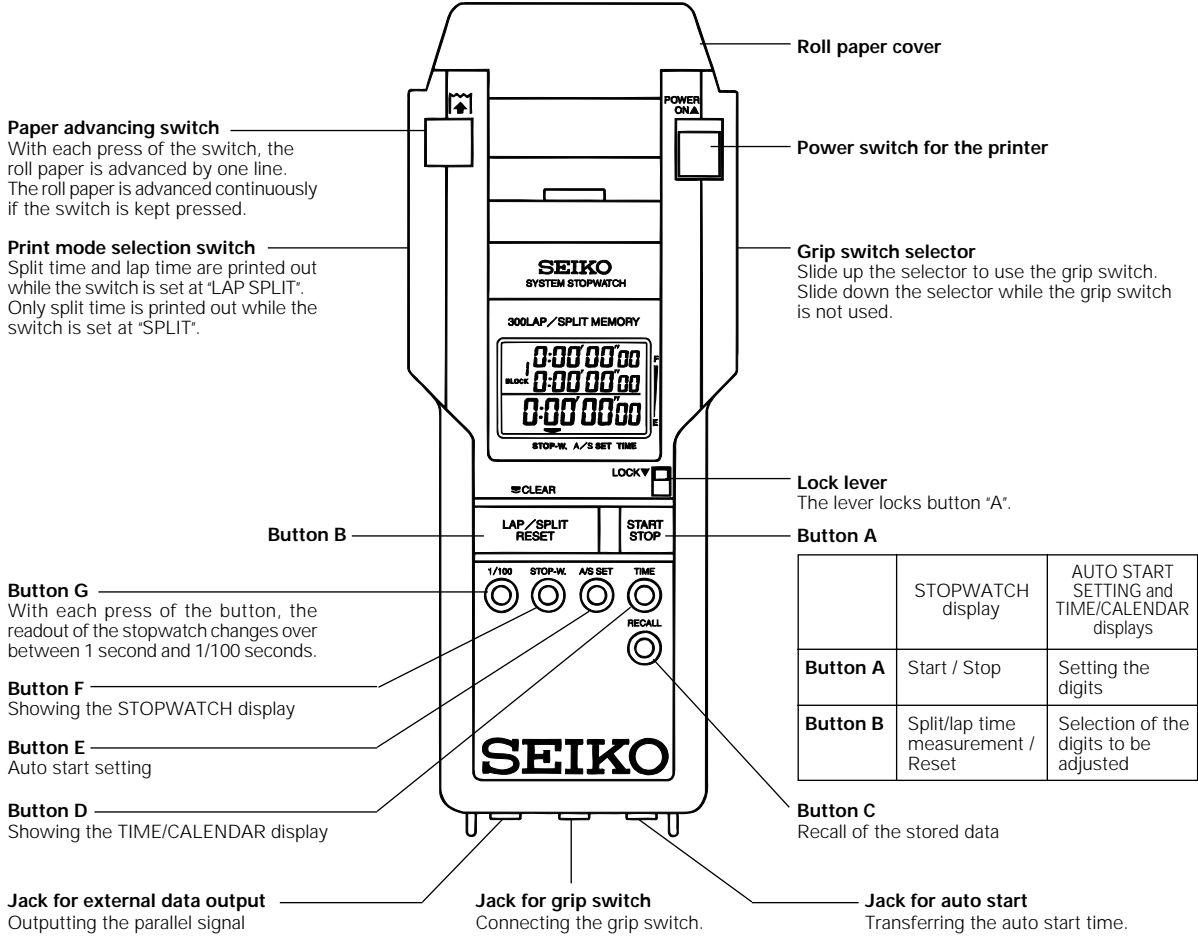

• **Checking the changeover of displays**

The display changes over as follows by pressing the respective buttons.

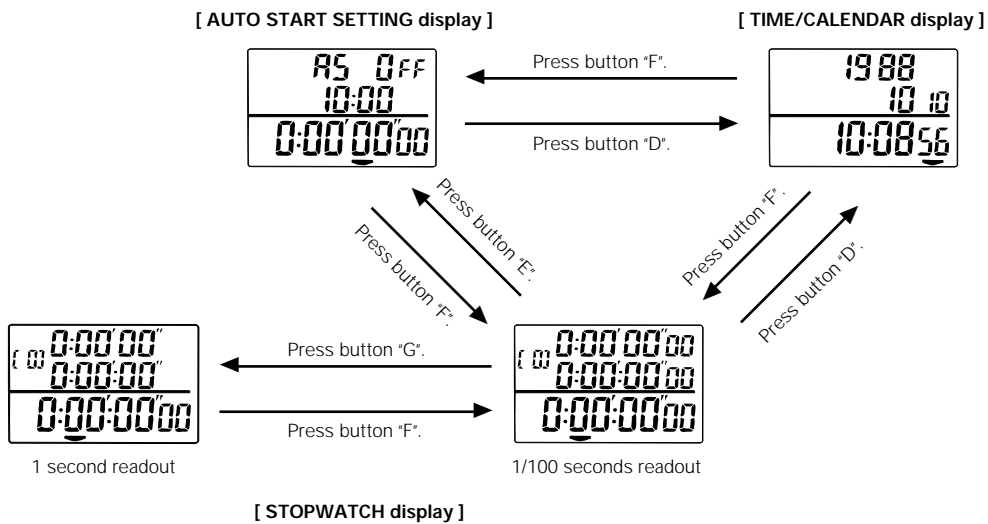

**Notes:**

1. Reset the display to "00" before changing over the readout of the measurement.
2. If the display is reset after the measurement is made with 1 second readout, the display automatically returns to 1/100 seconds readout.

• **All the segments lit up**

Press buttons "A" and "B" at the same time in the TIME/CALENDAR display to light up all the segments of the display.

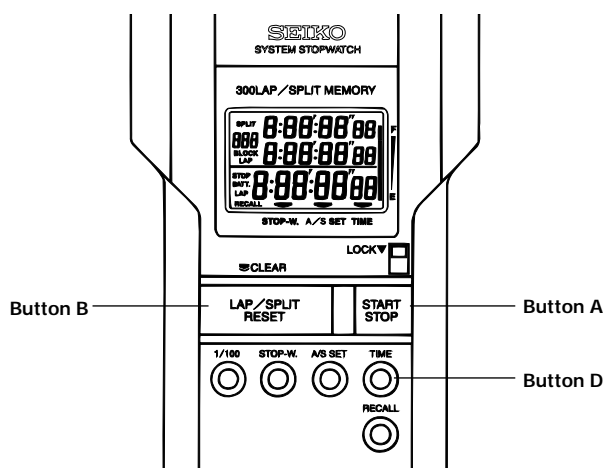

- \* If the stopwatch is left untouched with all the segments lit up, it will automatically return to the TIME/CALENDAR display in 1 to 2 minutes. To return to the TIME/CALENDAR display manually, press button "D".
- \* To measure the time accuracy with the quartz tester, light up all the segments of the display.

• **Repairing defective segments**

Check the following.

1. Check if the segment electrode of the circuit block A is soiled.
2. Check if the connector is soiled or if dust or lint sticks to it.

• **Checking the printing of the printer**

1. Slide up the print mode selection switch to "LAP SPLIT".
2. Turn on the power switch. The roll paper is advanced by one line.
3. Press the paper advancing switch. The roll paper is advanced by one line with each press of the switch.
4. Press button "F" to show the STOPWATCH display. Check that the digits are reset to "00".
  - \* When the stopwatch is counting, press button "A" to stop the measurement, and then, press button "B" to reset the digits to "00".
5. Press button "A" to check if year, month, date and starting time are printed out. (→ a)
6. Press button "B" several times to check if lap times and split times are printed out successively. (→ b)
7. Press button "A" to check if the finish time is printed out. (→ c)

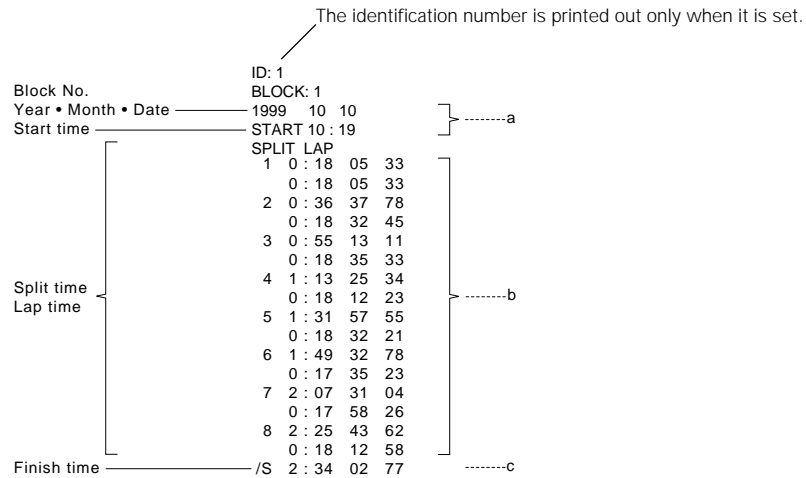

• **Checking the auto start function**

1. Press button "D" to show the TIME/CALENDAR display, and then, check the current time.
2. Press button "E" to show the AUTO START SETTING display.

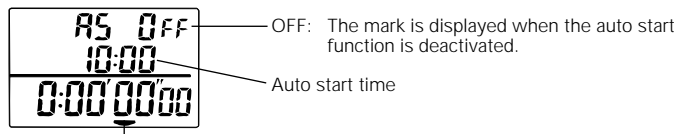

AUTO START SETTING display indicator:  
The mark indicates that the AUTO START SETTING display is being shown.

3. Press button "B" to select the digits to be adjusted (flashing).



4. Press button "A" to advance the flashing digits 2 minutes ahead of the current time.
5. Press button "B" again to enter the designated auto start time in memory. The stopwatch is ready to start at the designated time. Then, press button "F" to show the STOPWATCH display.
6. The buzzer rings with three beeps 3 seconds before the designated auto start time.
7. Check if the stopwatch starts measuring when the buzzer stops beeping.

• **Time/calendar setting**

1. Press button "D" to show the TIME/CALENDAR display.
2. Press button "B" to select the digits to be adjusted.  
With each press of the button, the digits to be adjusted change over in the following order.

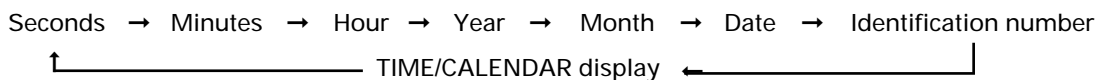

3. Press button "A" to set the digits.
4. Press button "B" to return to the TIME/CALENDAR display.