

TECHNICAL GUIDE

SEIKO DIGITAL QUARTZ

CAL. A827A
CAL. A828A

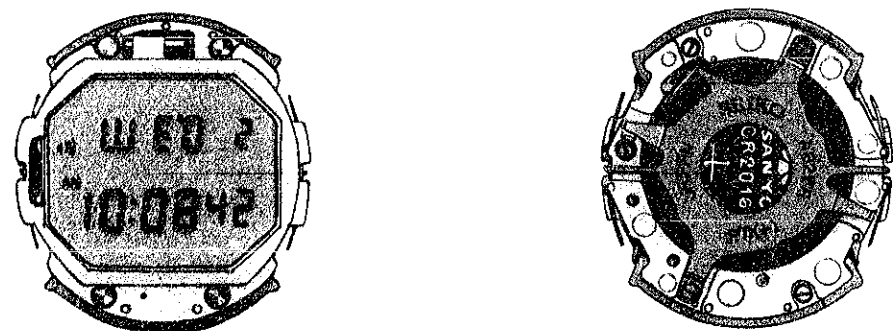

CONTENTS

I. SPECIFICATIONS	1
II. STRUCTURE OF THE CIRCUIT BLOCK	1
III. DISASSEMBLING, REASSEMBLING AND LUBRICATING OF THE CASE	2
IV. CHECKING AND ADJUSTMENT	5

I. SPECIFICATIONS

Item	Cal. No.	A827A	A828A
Display medium		Nematic Liquid Crystal, FEM (Field Effect Mode)	
Liquid crystal driving system		Multiplex driving system	
Display system		<ul style="list-style-type: none"> • Time and calendar function (12- or 24-hour indication) • Alarm function • Stopwatch function 	
		<ul style="list-style-type: none"> • Multi-timer function Preset timer modes and other times to be set: 3MIN, 5MIN, 10MIN, 15MIN, 20MIN, 40MIN, 45MIN, 60MIN, and any other desired amount of time up to 2 hours and 59 minutes in the unit of one minute 	<ul style="list-style-type: none"> • Timer function • Speedometer function Distances to be set: 0.2km, 0.4km, 1km, 6km, 10km, 50km, 100km, and any other desired distances up to 699.9km in the unit of 0.1km
Additional mechanism		<ul style="list-style-type: none"> • Alarm test system • Hourly time signal • Automatic calendar display system • Function changeover confirmation sound ("beep") • Illuminating light 	
Loss/gain		Monthly rate at normal temperature range: less than 15 seconds	
Movement size	Outside diameter	ϕ 31.4 mm (29.6 mm between 6 o'clock and 12 o'clock sides) (27.6 mm between 3 o'clock and 9 o'clock sides)	
	Casing diameter	ϕ 28.0 mm	
	Height	4.9 mm without battery	
Regulation system		Trimmer condenser	
Measuring gate by quartz tester		Any gate is available.	
Battery		Lithium battery Sanyo CR2016, Maxell CR2016, Matsushita BR2016 Battery life is approximately 3 years. Voltage: 3.0V for Sanyo CR2016, Maxell CR2016 2.8V for Matsushita BR2016	

II. STRUCTURE OF THE CIRCUIT BLOCK

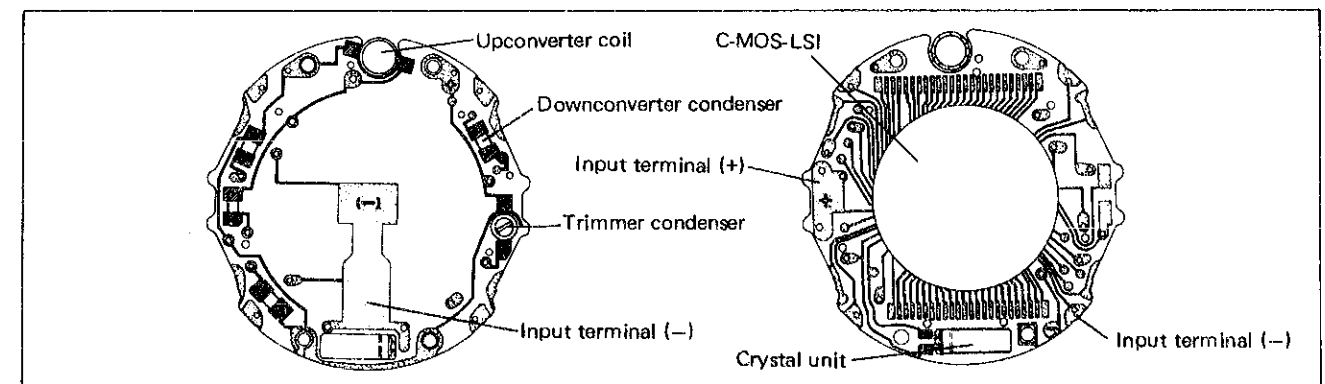

III. DISASSEMBLING, REASSEMBLING AND LUBRICATING OF THE CASE

- Case No. A828-400A is taken here as an example to describe the disassembling and reassembling procedures.

Disassembling procedures Figs.: ① → ⑪ **Lubricating:**
 Reassembling procedures Figs.: ⑪ → ① **Type of oil** **Oil quantity**
 Silicone-grease 500,000 c.s. ◯◇ Normal quantity

- Case back ~ Transmission pin

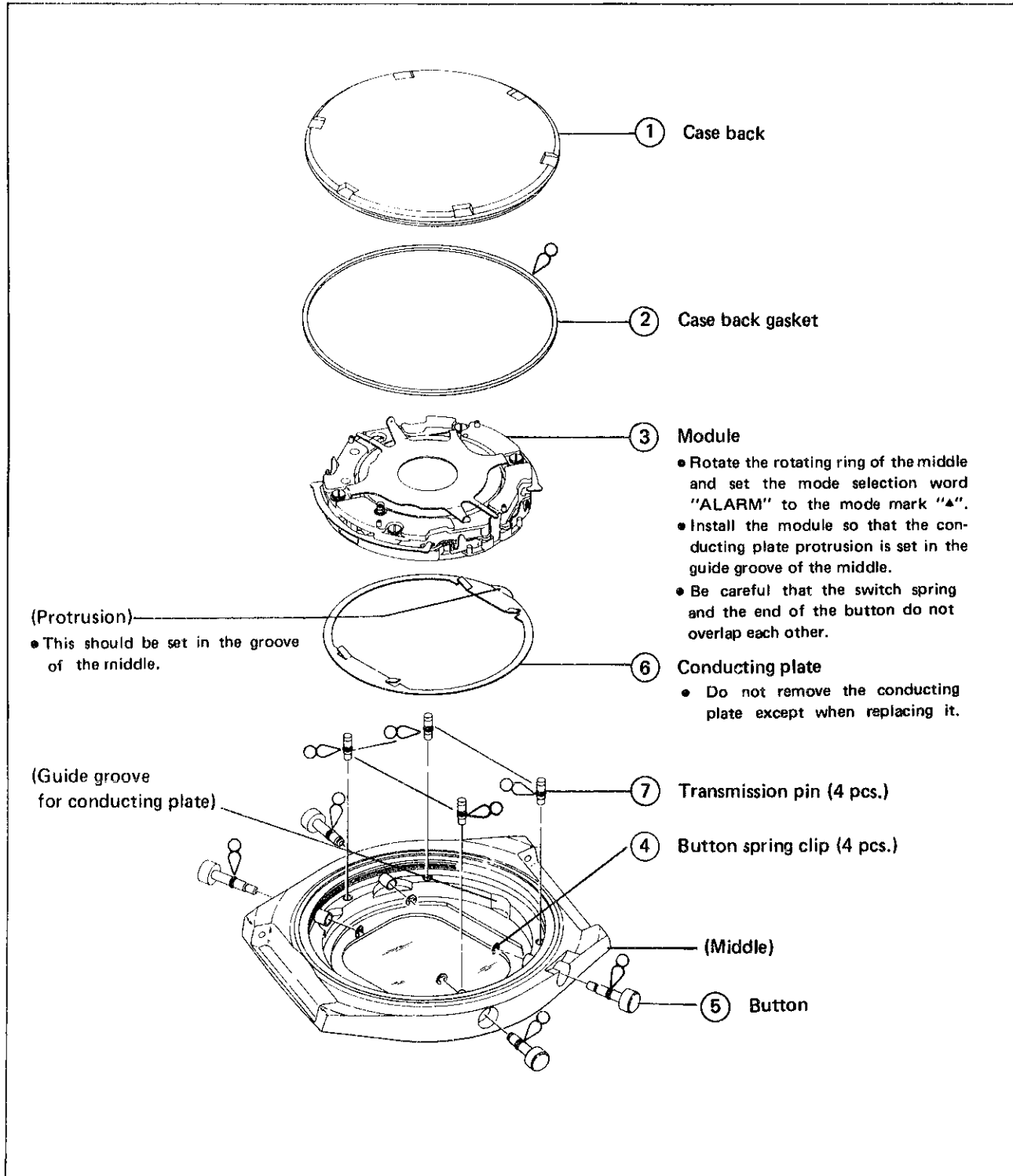

- Remarks on disassembling and reassembling

⑥ Conducting plate

How to disassemble:

Hold the conducting plate at either ← marked position with tweezers, and release it from each button axis by bending it as shown in the illustrations on the right.

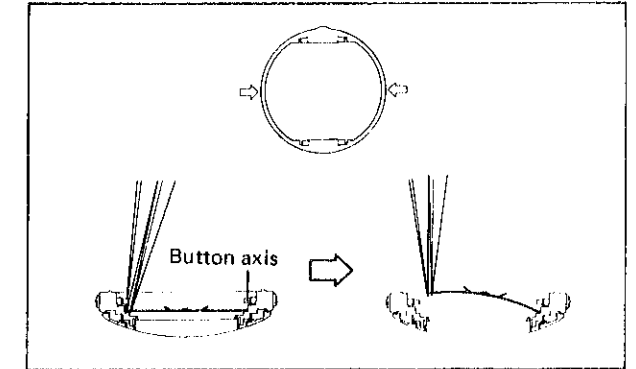

How to reassemble:

- Set one side of the conducting plate below the button axes, while making sure that the conducting plate protrusion is set in the groove of the middle and that its face is not set upside down.

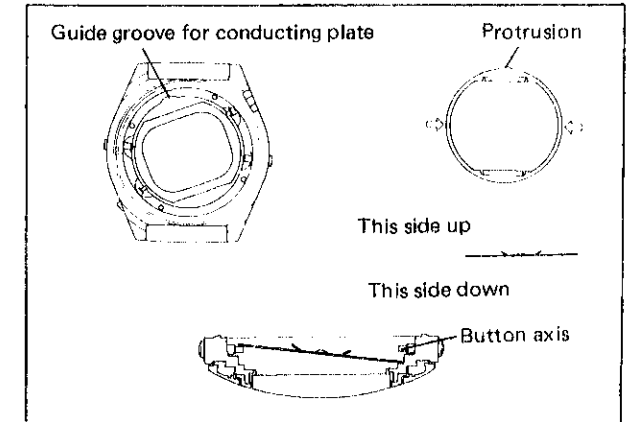

- Hold the other side of the conducting plate with tweezers, and set it below the button axes on that side by bending it as illustrated.

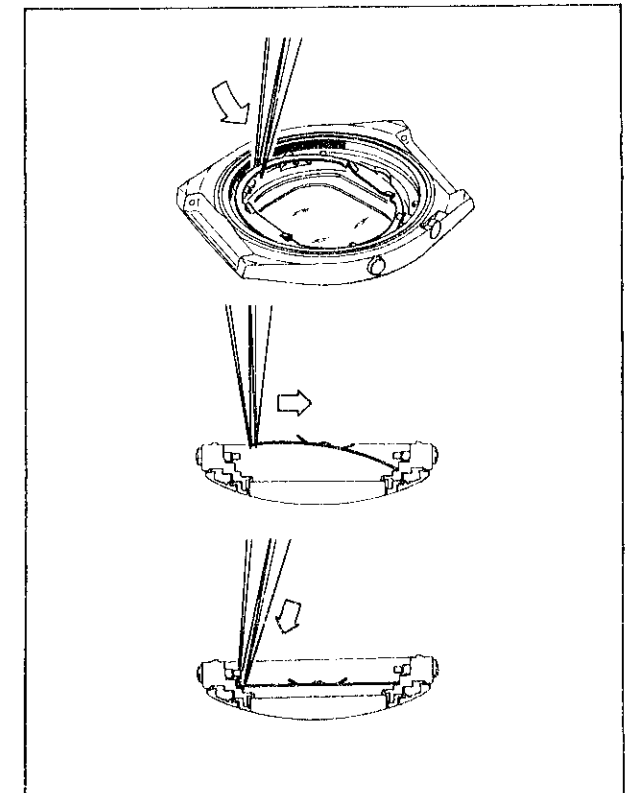

● Rotating ring ~ Middle

⑧ Rotating ring

How to disassemble

- Pry it up at the position below the rotating ring protrusion with the case opener.
- Be sure to cover the tip of the case opener with a vinyl sheet to prevent the middle and rotating ring from being scratched.

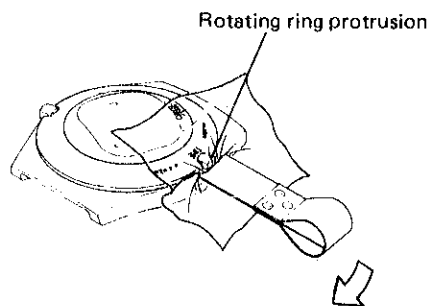

How to reassemble

- When installing the rotating ring, press it by hand after assuring the module is not set in the middle. Apply a small quantity of silicone grease to the portion where the rotating ring fastens to the middle. That facilitates the work.

⑨ Glass

How to disassemble

1. Remove the rotating ring.
2. Hold the middle with the supporting disk.
3. Push the glass with the inserting disk (S-162) directly and remove it.

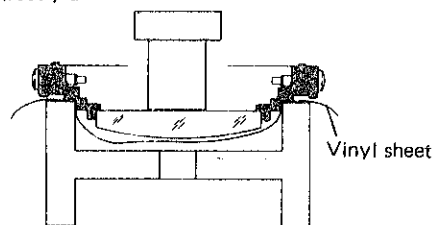

How to reassemble

1. Set a new glass gasket.
2. Support the inside of the middle with the supporting disk.
3. Set the glass, and then push it in tight with the inserting disk.

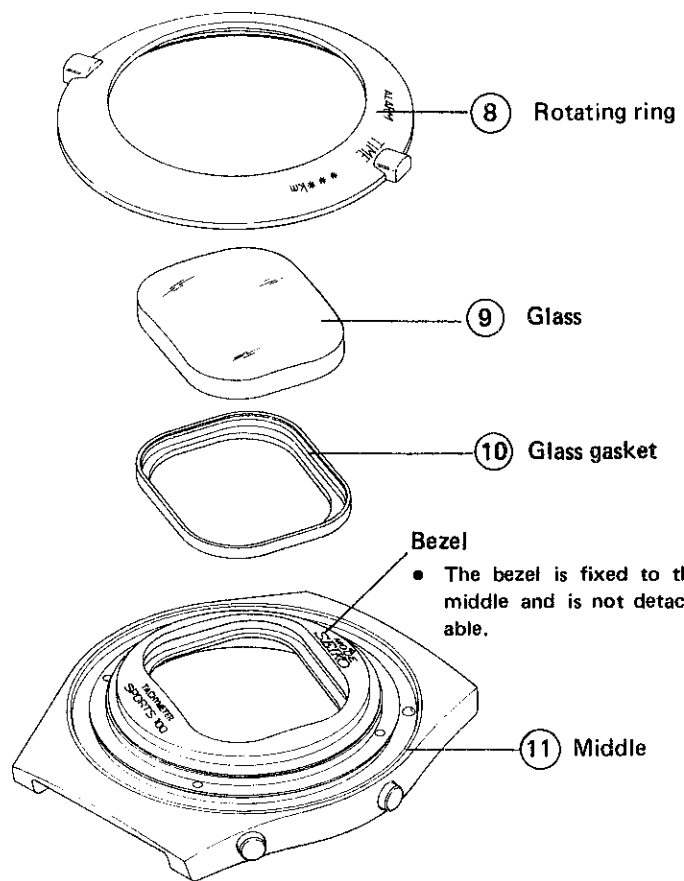
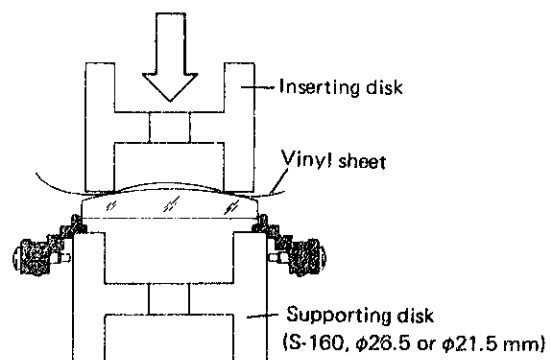

⑩ Glass gasket

How to disassemble

- Holding the glass gasket with tweezers, first bend it toward its center and then push it outward as shown in the illustrations below.

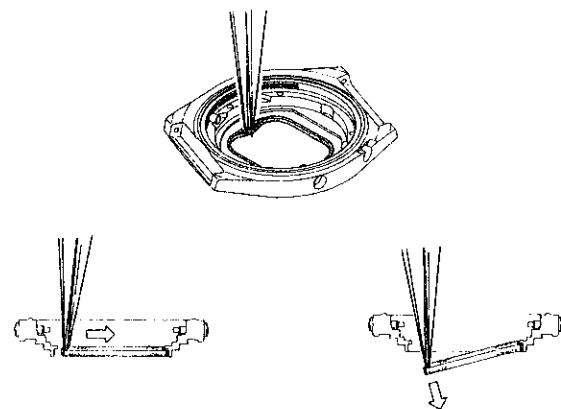

IV. CHECKING AND ADJUSTMENT

For checking and adjustment, refer to the "TECHNICAL GUIDE, SEIKO DIGITAL QUARTZ Cal. A829A".

● Remarks

After checking battery voltage or replacing battery, push the 4 buttons at the same time.