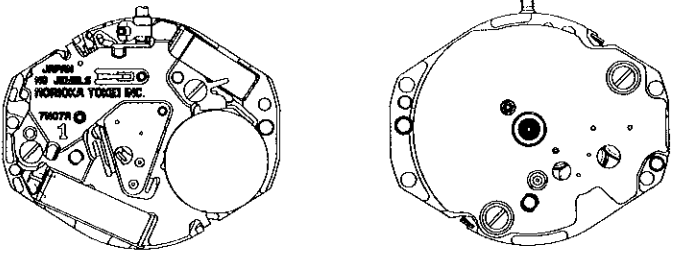

PARTS CATALOGUE / TECHNICAL GUIDE

Cal. 7N07A

[SPECIFICATIONS]

Item		Cal. No.	7N07A
Movement			 <p style="text-align: right;">(x 2.0)</p>
Movement size	Outside diameter	ϕ 18.2 mm 15.3 mm between 3 o'clock and 9 o'clock sides	
	Casing diameter	ϕ 17.8 mm 15.3 mm between 3 o'clock and 9 o'clock sides	
	Height	2.9 mm	
Time indication		3 hands (Hour, minute and small second hands)	
Driving system		Step motor (Load compensated driving pulse type)	
Additional mechanism		<ul style="list-style-type: none"> • Train wheel setting device • Electronic circuit reset switch • Battery life indicator 	
Loss/gain		Monthly rate at normal temperature range: less than 15 seconds	
Regulation system		Nil	
Measuring gate by quartz tester		Use 10-second gate.	
Battery		SEIKO SR621SW, Maxell SR621SW, SONY SR621SW, Matsushita SR621SW, EVEREADY 364 Battery life is approximately 2 years. Voltage: 1.55V	
Jewels		0 jewel	

SEIKO CORPORATION

PARTS CATALOGUE

Cal. 7N07A

Disassembling procedures Figs. : ① → ③②

Reassembling procedures Figs. : ③② → ①

Lubricating: Types of oil **Oil quantity**

 ● Moebius A ○ Normal quantity

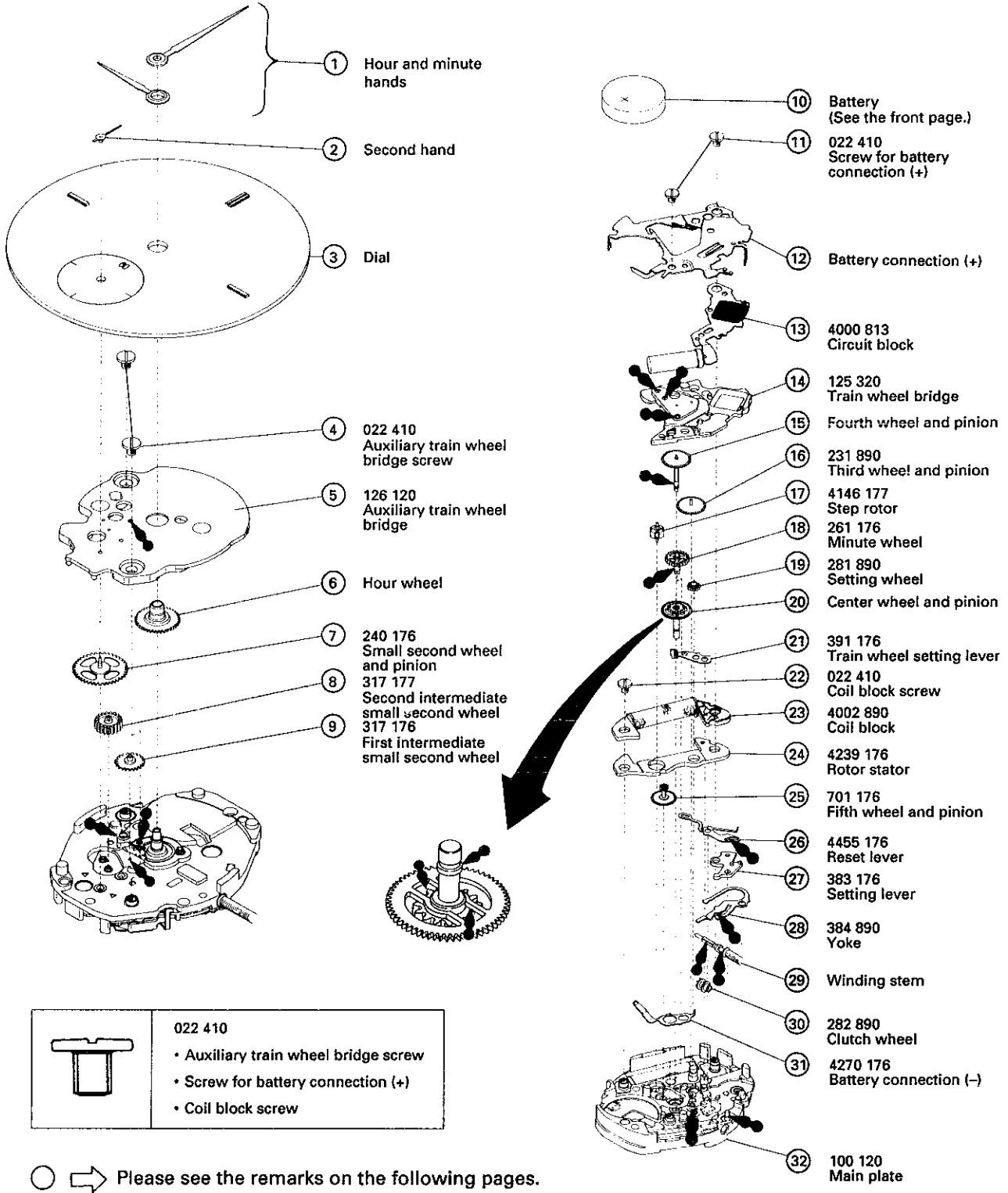

	022 410
	• Auxiliary train wheel bridge screw
	• Screw for battery connection (+)
	• Coil block screw

○ ➔ Please see the remarks on the following pages.

PARTS CATALOGUE

Cal. 7N07A

Remarks:



- ⑥ Hour wheel
- ⑮ Fourth wheel and pinion
- ⑳ Center wheel and pinion

• **Discrimination of the installing height of the hands**

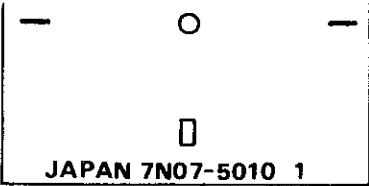
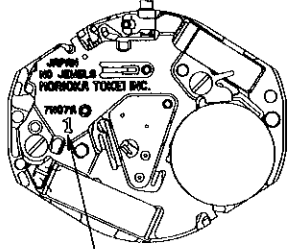
Cal. 7N series watches have numerals printed on the dial and the movement to indicate the installing heights of hands. When repairing, refer to the table below.

Discrimination	Height	Short type	Standard type	Extra long type
	Numeral for discrimination	1	2	4
Printed on		Dial		Movement
Printed position		Ex.) Short type  The numeral is printed at the right end.		Ex.) Short type  The numeral is printed below the calibre number.

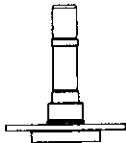
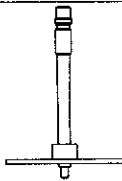
Combination:

Numeral for discrimination	Center wheel and pinion	Fourth wheel and pinion	Hour wheel
1	 221 176	 241 176	 271 382

Note: When ordering the movement, specify the installing height of hands using the numeral for discrimination. If the numeral is not printed on the battery connection (+), check the dial for the numeral or see the tables above and find the numeral from the shape of the parts.

PARTS CATALOGUE

Cal. 7N07A

⑫ Battery connection (+) 4268 750

Note: The battery connection (+) we are supplying has no calibre number nor numeral printed on it for discriminating the installing height of hands.

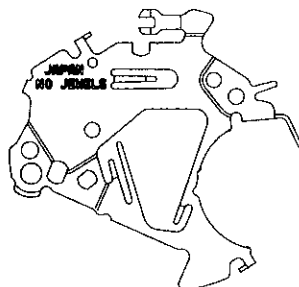

⑲ Winding stem 351 890

The type of winding stem is determined based on the design of cases.
Check the case number and refer to "SEIKO Casing Parts Catalogue" to choose a corresponding winding stem.

TECHNICAL GUIDE

Cal. 7N07A

- The explanation here is only for the particular points of Cal. 7N07A.
- For the repairing, checking and measuring procedures, refer to the "TECHNICAL GUIDE, GENERAL INSTRUCTIONS".

I. STRUCTURE OF THE CIRCUIT BLOCK

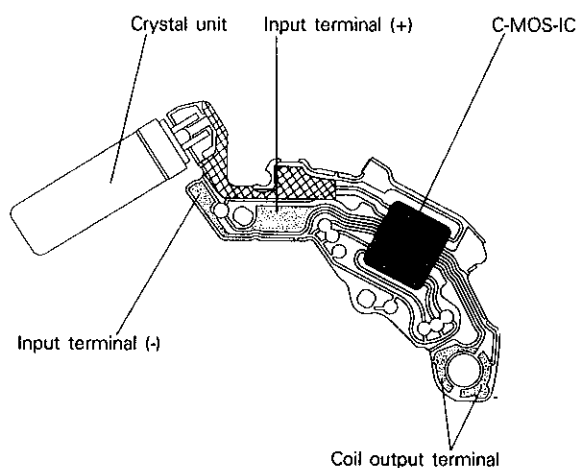

II. REMARKS ON DISASSEMBLING AND REASSEMBLING

Use the universal movement holder for disassembling and reassembling.

- ① Hour and minute hands
- ② Second hand

• Remarks on installing

When installing the hands, remove the battery and place the movement directly on a flat metal plate or the like.

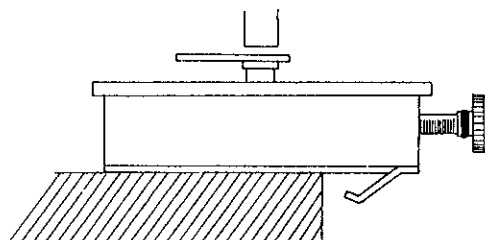

- ⑩ Battery

• How to install

Insert the battery aslant from the direction shown by the arrow.

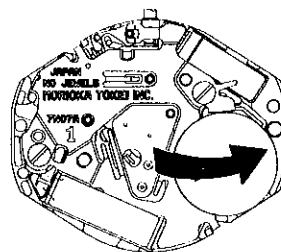

- ⑪ Screw for battery connection (+)

Fasten the screw on the crystal unit side while holding down the edge of the crystal unit.

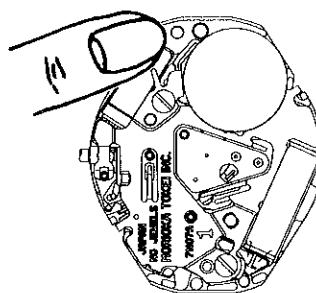

- ⑫ Battery connection (+)

• How to install

Have the hooking portion (2 places) catch the main plate.

In disassembling and reassembling, take care not to deform the hooking portions.

After installing the battery connection (+), check that the two hooking portions securely catch the main plate.

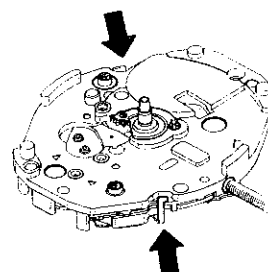

⑭ Train wheel bridge

• Setting position

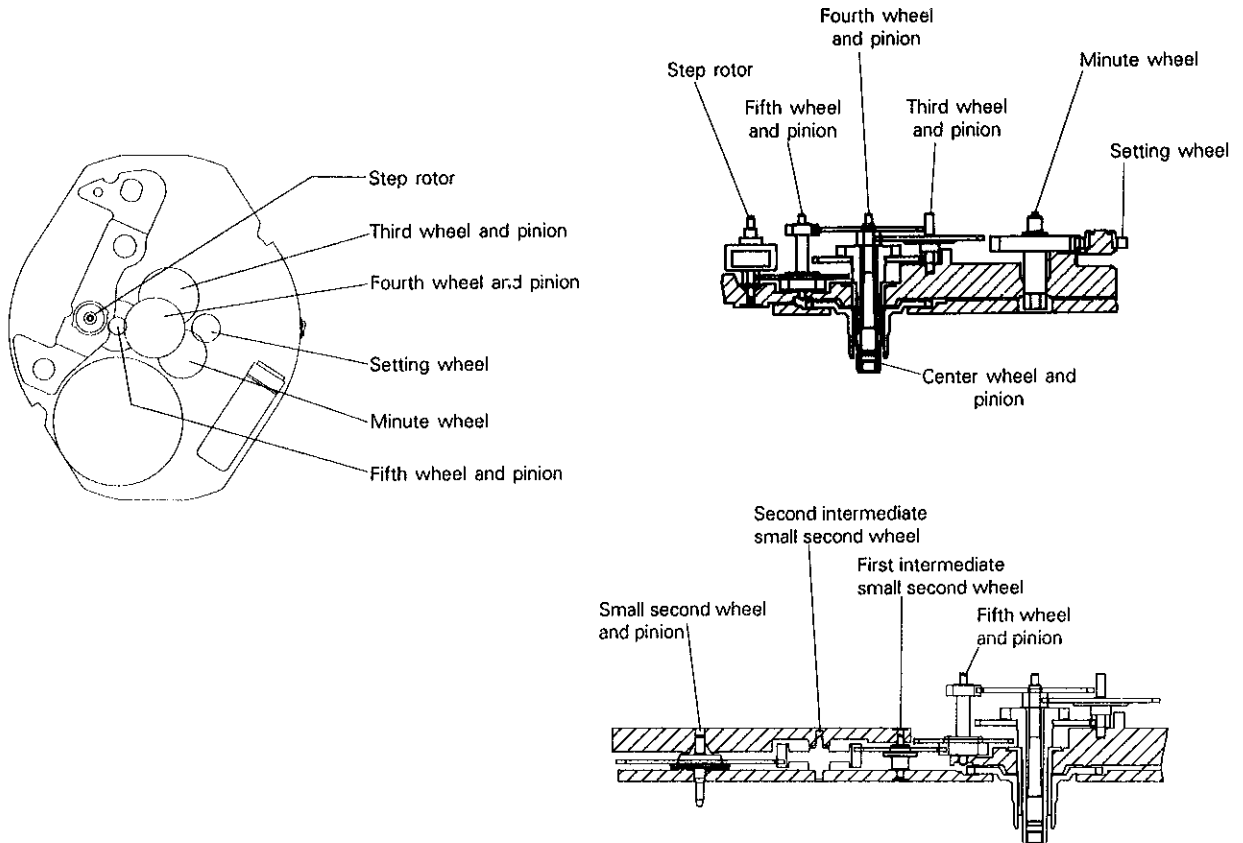

Notes: 1. Since the third wheel and pinion, step rotor and minute wheel are made of plastic, take care not to damage them in disassembling and reassembling.
 2. Set the step rotor with its pinion at the main plate side.

⑳ Train wheel setting lever

㉑ Reset lever

㉒ Setting lever

㉓ Yoke

• Setting position

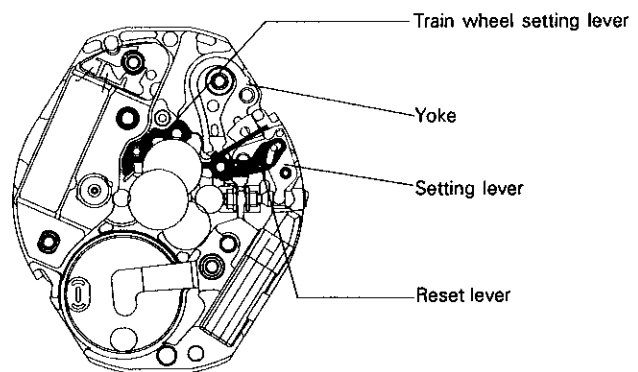

Note: Take care not to deform the spring portion of the yoke.

III. VALUE CHECKING

- Coil block resistance

2.4K Ω ~ 2.8K Ω

- Current consumption

For the whole of the movement : less than 1.3 μ A
For the circuit block alone : less than 0.4 μ A

Remarks: When the current consumption exceeds the standard value for the whole of the movement but within the standard value range for the circuit block alone, overhaul and clean the movement parts and then measure current consumption for the whole of the movement again. The reason for this is that the driving pulse generated to compensate for a heavy load that may be applied to the gear train, etc., is one possible cause of excessive current consumption by the whole of the movement.

