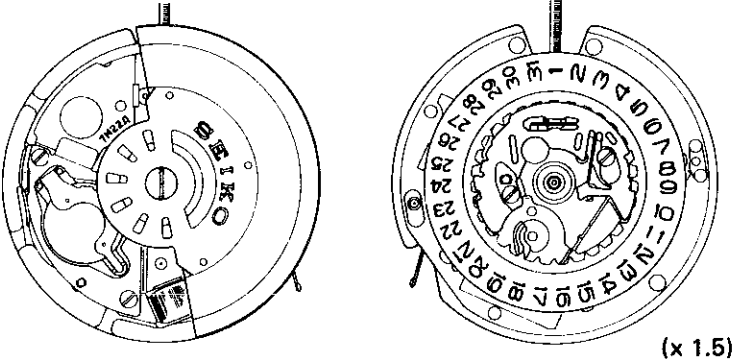

# PARTS CATALOGUE/ TECHNICAL GUIDE

## Cal. 7M22A

### [SPECIFICATIONS]

Cal. No.		7M22A
Item		
Movement		
Movement size	Outside diameter	φ27.6 mm
	Casing diameter	φ27.0 mm
	Height	4.2 mm
Time indication		3 hands
Driving system		Step motor (Load compensated driving pulse type)
Additional mechanism		<ul style="list-style-type: none"> <li>• Automatic generating system</li> <li>• Electronic circuit reset switch</li> <li>• Train wheel setting device</li> <li>• Date calendar</li> <li>• Instant setting device for date calendar</li> <li>• Energy depletion forewarning function</li> </ul>
Loss/gain		Monthly rate at normal temperature range: less than 15 seconds
Regulation system		Nil
Measuring gate by quartz tester		Use 10-second gate.
Power supply	Power generator	Automatic generating system
	Capacitor	Matsushita EECW 2R-4E 334
Operating voltage range		Capacitor voltage: 0.5 ~ 2.3V
Expected life per charge		From full charge to stoppage : Approx. 72 hours From the start of the second hand's 2-second step movement to stoppage : Approx. 12 hours
Jewels		5 jewels

Disassembling procedures Figs.: ① ~ ④⑤

Reassembling procedures Figs.: ④⑤ ~ ①

Lubricating: Types of oil

Oil quantity



● Moebius A

○ Normal quantity

○ SEIKO Watch Oil S-6

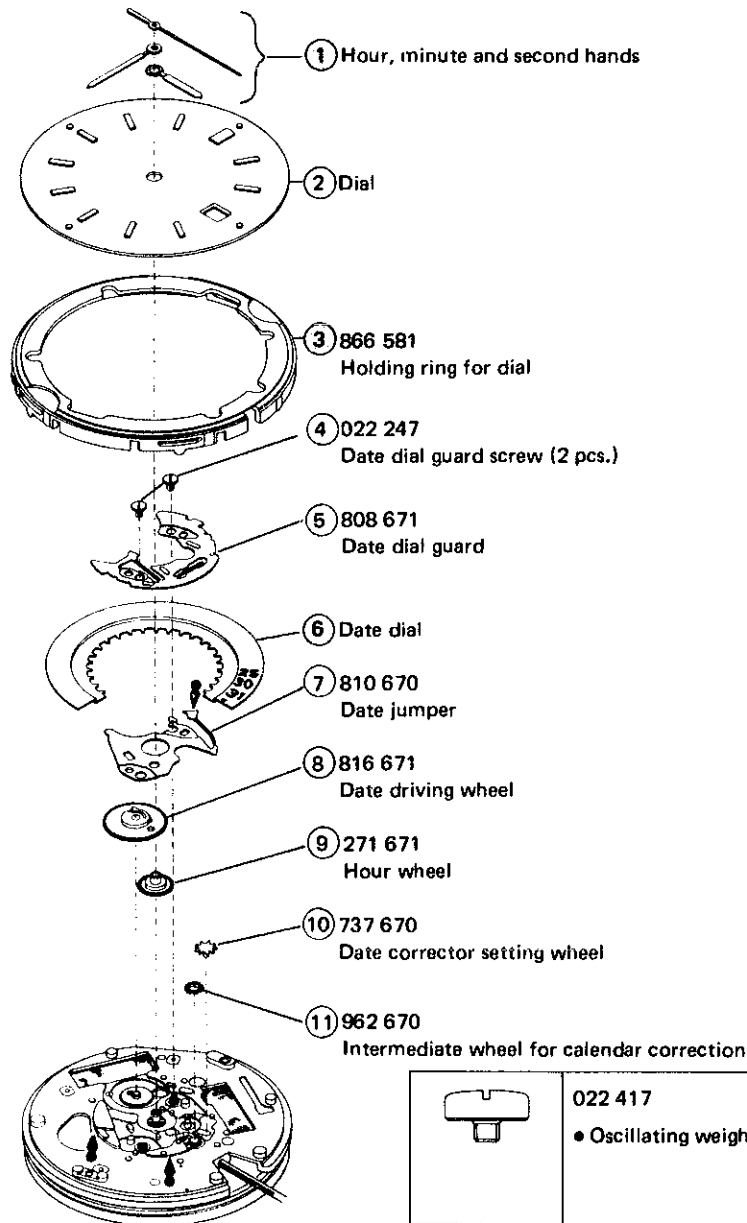
○ Extremely small



	<p>022 417</p> <ul style="list-style-type: none"> <li>● Oscillating weight screw (1 pc. )</li> </ul>
	<p>022 247</p> <ul style="list-style-type: none"> <li>● Circuit block cover screw (3 pcs.)</li> <li>● Train wheel bridge screw (1 pc. )</li> <li>● Date dial guard screw (2 pcs.)</li> <li>● Capacitor clamp screw (2 pcs.)</li> <li>● Oscillating weight bridge screw (2 pcs.)</li> </ul>

○ ➡ Please see the remarks on the following pages.

# PARTS CATALOGUE

Cal. 7M22A

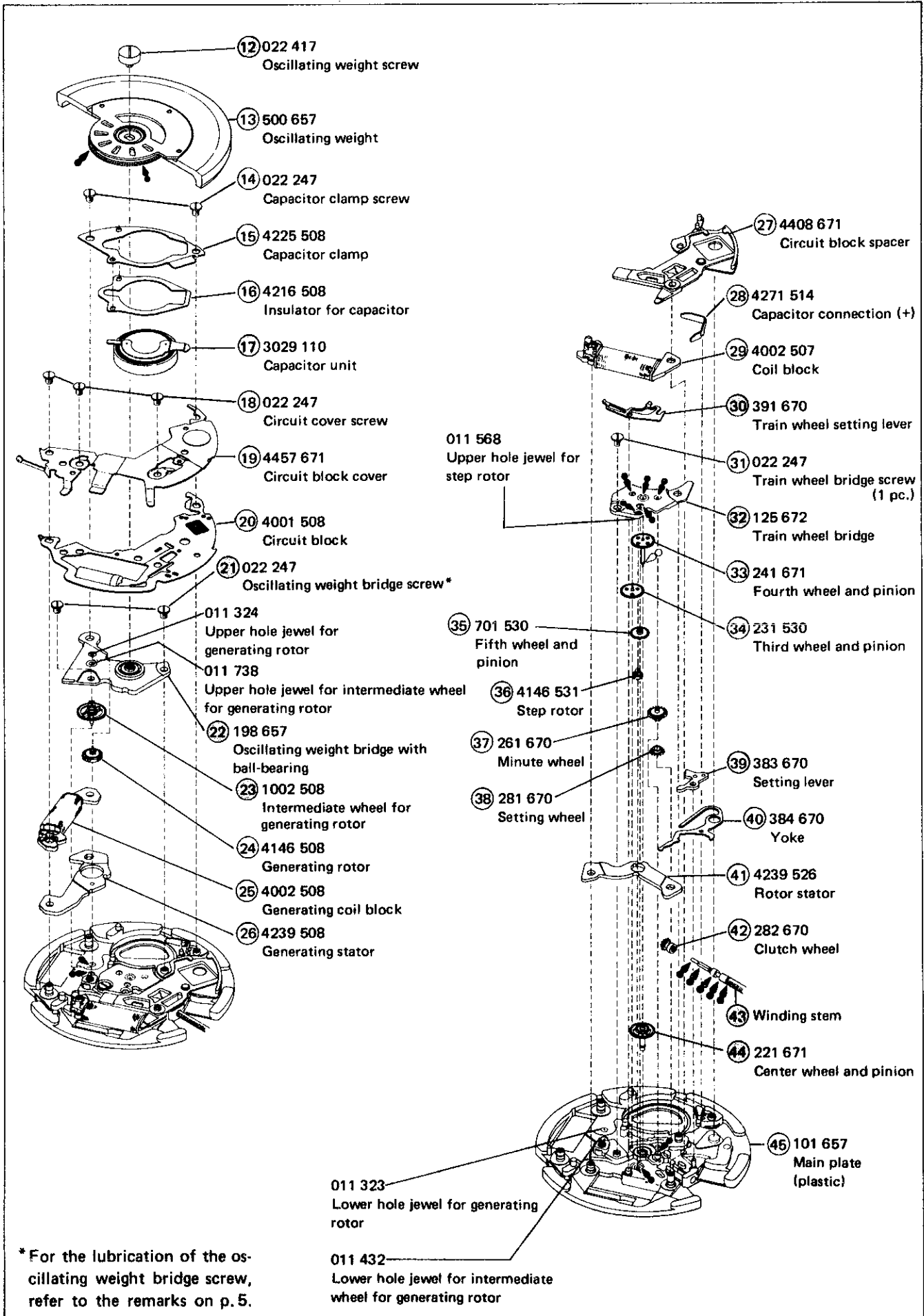

**Remarks:**

- ③ Holding ring for dial 866 581
- ④③ Winding stem 351 670

The type of these parts are determined based on the design of cases. Check the case number and refer to "SEIKO Casing Parts Catalogue" to choose a corresponding winding stem.

- ⑥ Date dial

Part code	Position of crown	Position of calendar	Color of figure	Color of background
801 954	3 o'clock	3 o'clock	Black	White
801 956	3 o'clock	6 o'clock	Black	White
878 508	3 o'clock	6 o'clock	Black	Gold

The type of date dial is determined based on the design of cases.

For details, refer to "SEIKO Casing Parts Catalogue".

If any other type of date dial is required, please specify (1) Cal. No., (2) the crown position, (3) the calendar frame position, (4) Dial No. and (5) the color.

## TECHNICAL GUIDE

- The explanation here is only for the particular points of Cal. 7M22A.
- For the repairing, checking and measuring procedures, refer to the "TECHNICAL GUIDE, GENERAL INSTRUCTIONS".

### I. STRUCTURE OF THE CIRCUIT BLOCK

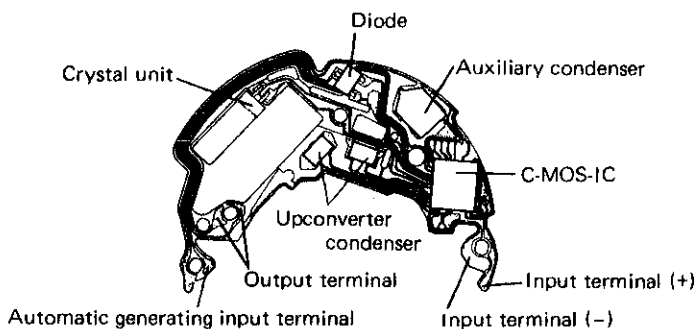

### II. REMARKS ON DISASSEMBLING AND REASSEMBLING

Use the universal movement holder for disassembling and reassembling.

# TECHNICAL GUIDE

## ① Hands

### • How to install

Place the movement directly on the riveting plate shown in the illustration or a flat metal plate with the oscillating weight side down, so that the oscillating weight screw will not be damaged. Then press in the hands.

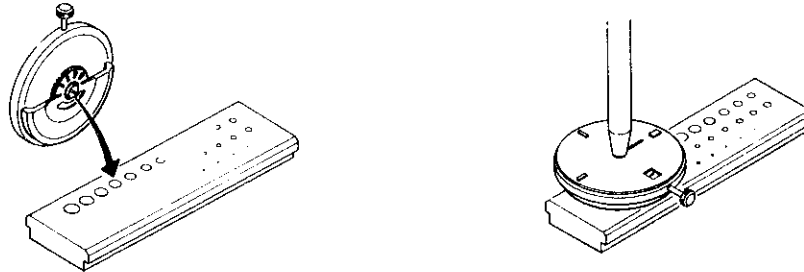

## ⑫ Oscillating weight screw

After tightening the oscillating weight screw, check that the oscillating weight does not touch the 9 o'clock side of the capacitor lead terminal and that it moves smoothly.

## ⑰ Capacitor unit

- Be sure to observe the correct polarity of the capacitor unit. The lead terminal is installed on the (-) side as shown in the illustration.
- Set the 12 o'clock side of the capacitor lead terminal between the collars of the circuit block spacer.

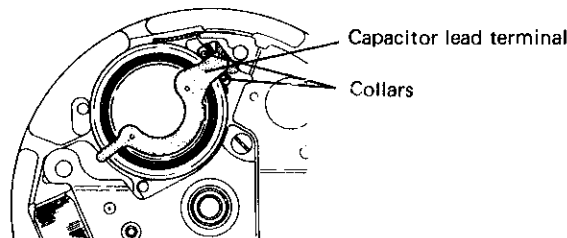
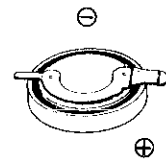

- Capacitor voltage is approximately 0.3V when measured for the whole of the movement. However, when measured for the capacitor for after-sales servicing alone, the voltage is 0V.

## ⑳ Oscillating weight bridge screw

### • Lubricating

Before tightening the oscillating weight bridge screw, be sure to lubricate the upper and lower parts of the generating rotor and intermediate wheel for generating rotor in the quantity specified in the illustration.

- After tightening the oscillating weight bridge screw, turn the pinion of the intermediate wheel for generating rotor with tweezers to check that the rotor turns smoothly.
- Be sure to lubricate the generating rotor and the intermediate wheel for generating rotor at the positions indicated by the lubricating marks in the exploded view on page 3.

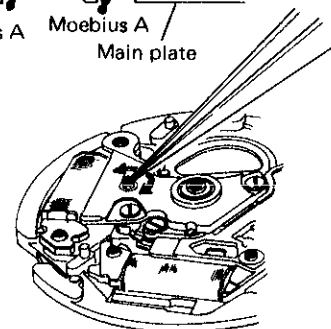
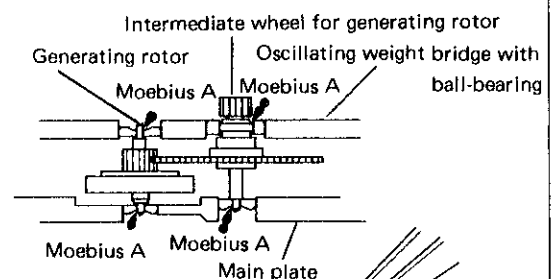

# TECHNICAL GUIDE

## 22 Oscillating weight bridge with ball-bearing

- Lubricating

Be sure to lubricate the ball-bearing.

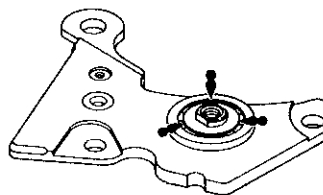

## 23 Intermediate wheel for generating rotor

- Lubricating

Refer to the illustration on the right.

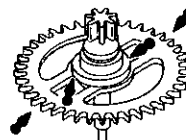

## 30 Train wheel setting lever

- Setting position and lubricating

Set the yoke and the train wheel setting lever into position. Lubricate the contacting portion of the yoke and the setting lever.

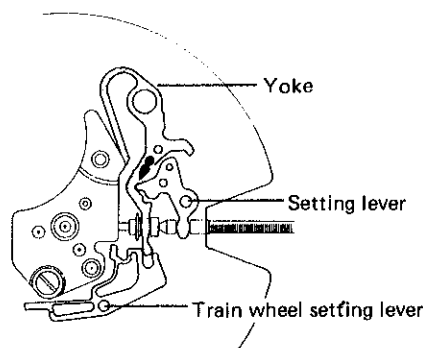

## 32 Train wheel bridge

- Setting position

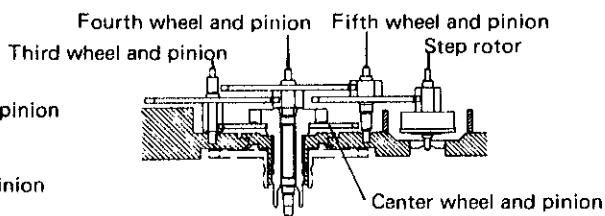
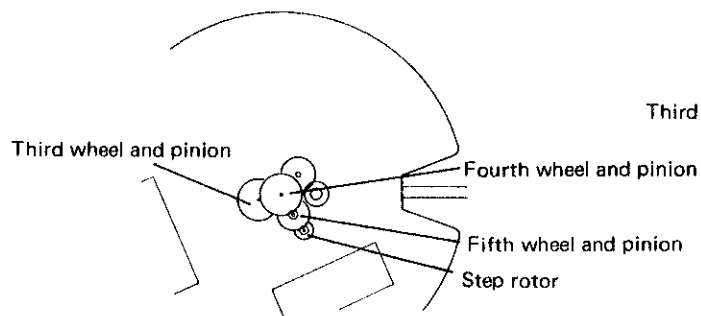

## 44 Center wheel and pinion

- Lubricating

Refer to the illustration on the right.

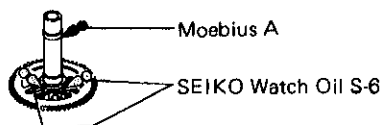

## III. VALUE CHECKING AND ADJUSTMENT

- Coil block resistance

1.8K $\Omega$  ~ 2.4K $\Omega$

- Generating coil block resistance

300 $\Omega$  ~ 400 $\Omega$

# TECHNICAL GUIDE

- **Current consumption**

For the whole of the movement:  $1.5\mu\text{A}$   
For the circuit block alone :  $0.5\mu\text{A}$

- **Measuring the current consumption for the whole of the movement**

- 1) Connect the tester as shown in the illustration.

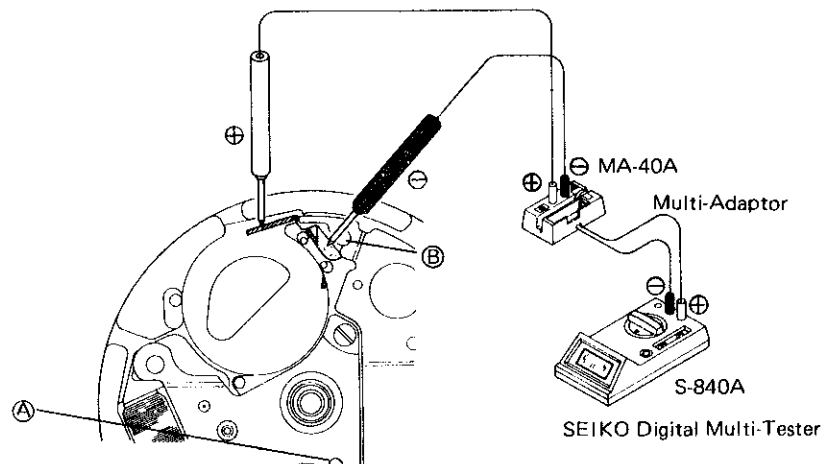

- 2) Start the measurement 16 seconds after connecting the tester.
- 3) When measuring, look through the upper hole jewel for step rotor ( A ) in the illustration), to check that the step rotor is rotating.
- 4) If a stable measurement is not obtained for the current consumption, temporarily tighten the capacitor clamp screw, and then measure current consumption again.

- **Measuring the current consumption for the circuit block alone**

- 1) Start the measurement 16 seconds after connecting the tester.

**Remarks:**

When the current consumption exceeds the standard value for the whole of the movement but is less than the standard value for the circuit block alone, overhaul and clean the movement parts and then measure current consumption of the whole of the movement again.

The driving pulse generated to compensate a heavy load that may apply on the gear train, etc. is considered to cause excessive current consumption for the whole of the movement.

# TECHNICAL GUIDE

## ● Checking the automatic generating system

- 1) With the watch complete (case back opened), apply the probes of the tester to the capacitor unit as shown in the illustration to measure the initial voltage.
- 2) Close the case back temporarily, and swing the watch from side to side approximately 100 times rhythmically (at a rate of 1.5 times a second) with a snap of the wrist as shown in the illustration.
- 3) Remove the case back, and measure the voltage of the capacitor unit in the same manner as in the step 1) above.
- 4) If the voltage obtained has increased more than 0.1V from the initial voltage, the automatic generating system is normally operating.

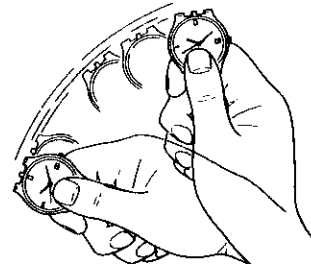
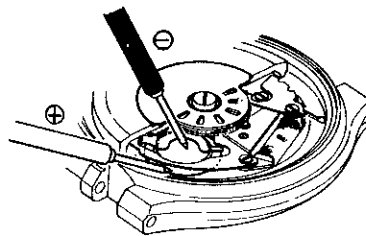

Ex.) Initial voltage : 0.5V → 0.6V: Normal operation

### Remarks:

- 1) When the watch completely stops, swinging it a few times moves the second hand at two-second intervals, but it stops after a few seconds.  
This is not a malfunction, indicating that the watch will normally operate if swung a few more times.
- 2) The automatic generating system will not work even if the crown is turned.

## ● Checking the normal operation of the watch

- 1) Swing the watch from side to side approximately 400 times rhythmically (at a rate of 1.5 times a second) with a snap of the wrist as shown in the illustration. Then, leave the watch untouched for 24 hours, and check that it keeps operating during the period.

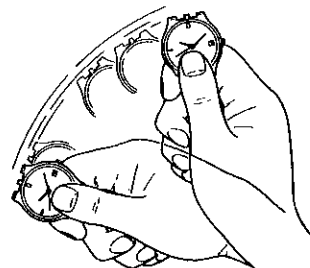

**Recharging information:** Number of swings required and the duration of charge until the watch stops operating

Number of swings	Duration of charge	Movement of the second hand
300	Approx. 12 hours	2-second step
400	Approx. 24 hours	1-second step
600	Approx. 48 hours	1-second step
800	Approx. 72 hours	1-second step

\* The table above assumes that the initial voltage of the capacitor unit is 0.5V.

### Remarks:

When the capacitor is replaced with a new one, the initial voltage is 0V and, therefore, swing the watch approximately 200 times more than specified in the table.