

Catalog No.



Cal. 4206A

Characteristics

Casing diameter : ϕ 17.2 mm
 Maximum height : 5.5 mm
 Vibration per hour : 21,600
 Automatic and auxiliary hand winding with sweep second
 Calendar (day and date)
 Instant setting device for day & date calendar
 Bilinear change-over system for day of the week
 "Dias" Shock Resistant Device

112 420

122 420

161 420

171 420

201 420

224 421

225 422

231 421

237 420

241 421

245 421

251 420

261 421

271 425

282 421

283 420

285 420

301 420

310 421

315 420

331 420

341 432

345 420

351 420

363 420

372 420

373 250

381 420

☆383 420

☆383 421

384 420

388 420

390 420

396 420

☆470 424

492 420

492 421

500 420

505 420

507 420

540 420

542 420

556 422

☆801 274

802 421

☆808 421

810 420

811 420

817 420

821 420

831 420

873 422

☆884 420

963 420

972 421

011 212

011 333

011 505

011 521

011 528

011 541

011 713

014 413

014 414

014 415

014 417

017 751

017 753

012 123

012 171

012 275

012 459

012 468

012 486

012 487

012 488

017 253

017 254

017 255

017 256

017 257

017 259

017 369

017 374

Calibre No.		Jewels	Style Name	
4206A		17j		
PART NO.	PART NAME	PART NO.	PART NAME	
112 420	Barrel & train-wheel bridge	☆884 422	Holding ring for dial	
122 420	Center wheel bridge	☆884 423		
161 420	Pallet cock	963 420	Snap for day star with dial disk	
171 420	Balance cock	972 421	Day-date corrector finger	
201 420	Complete barrel with arbor & main spring	011 212	Diashock upper cap jewel	
		011 212	Diashock lower cap jewel	
224 421	Center wheel with cannon pinion	011 333	Upper hole jewel for third wheel	
225 422	Cannon pinion	011 505	Upper hole jewel for pallet	
231 421	Third wheel & pinion	011 505	Lower hole jewel for pallet	
237 420	Ratchet intermediate wheel	011 521	Upper hole jewel for center wheel	
241 421	Fourth wheel & pinion	011 521	Lower hole jewel for center wheel	
245 421	Sweep second pinion	011 528	Upper hole jewel for escape wheel	
251 420	Escape wheel & pinion	011 528	Lower hole jewel for escape wheel	
261 421	Minute wheel	011 541	Upper hole jewel for fourth wheel	
271 425	Hour wheel	011 713	Lower hole jewel for sweep second pinion	
282 421	Clutch wheel		Stud screw	
283 420	Winding pinion	012 123	Day jumper screw	
285 420	Ratchet wheel	012 171	Barrel & train wheel bridge screw	
301 420	Jewelled pallet fork & staff	012 275	Balance cock screw	
310 421	Balance complete with stud	012 275	Setting lever spring screw	
315 420	Balance staff	012 275	Screw for rocking seat for idle wheel	
331 420	Roller with jewel	012 275	Case screw	
341 432	Regulator	012 459	Center wheel bridge screw	
345 420	Stud holder	012 468	Pallet cock screw	
351 420	Winding stem	012 468	Date driving wheel screw	
363 420	Sliding crown wheel spring	012 468	Date dial guard screw	
372 420	Joint stem (Movement portion)	012 468	Screw for Ball-bearing complete	
373 250	Joint stem (Crown portion)	012 486	Transmission wheel screw	
381 420	Click	012 487	Screw for oscillating weight	
☆383 420	Setting lever	012 488	Diashock upper frame	
☆383 421		014 413	Diashock lower frame	
384 420	Yoke (Clutch lever)	014 414	Diashock upper hole jewel with frame	
388 420	Setting lever spring	014 415	Diashock lower hole jewel with frame	
390 420	Setting lever axle	014 415	Diashock upper spring	
395 420	Friction spring for sweep second pinion	014 417	Diashock lower spring	
☆470 424	Day star with dial disk	☆017 253	Tube for barrel & train-wheel bridge screw	
492 420	Balance cock washer (0.015 mm thickness, gold)	☆017 253	Tube for balance cock screw	
492 421	Balance cock washer (0.028 mm thickness, silver)	☆017 253	Tube for rocking seat for idle wheel	
500 420	Oscillating weight	☆017 254	Tube for center wheel bridge screw (A)	
505 420	Transmission wheel	☆017 254	Tube for pallet cock screw (B)	
507 420	Transmission pinion	017 255	Tube for center wheel bridge screw (B)	
540 420	Dial leg holder	017 256	Tube for date driving wheel	
542 420	Rocking seat for idle wheel	017 257	Tube for date dial guard (A)	
556 422	Date finger	017 259	Tube for date dial guard (B)	
☆801 274	Date dial	017 369	Tube for pallet cock screw (A)	
☆801 275		017 374	Dial leg holder pin	
☆801 276		☆017 631	Tube for barrel & train-wheel bridge screw	
☆801 277		☆017 631	Tube for balance cock screw	
802 421	Date driving wheel	☆017 631	Tube for rocking seat for idle wheel	
☆808 421	Date dial guard	☆017 633	Tube for center wheel bridge screw (A)	
810 420	Date jumper	☆017 633	Tube for pallet cock screw (B)	
811 420	Date jumper spring	017 751	Lower bush for transmission pinion	
817 420	Intermediate date wheel	017 753	Upper bush for transmission pinion	
821 420	Ball-bearing for oscillating weight			
831 420	Pawl lever with jewel			
873 422	Day jumper			
☆884 420	Holding ring for dial			
☆884 421				

☆ ⇨ Please see remarks on the reverse page.
 Part numbers in light letters are not shown in photos.

Calibre No. 4206A	Jewels 17j	Style Name
-----------------------------	----------------------	------------

Remarks :

Setting lever

☆383 420 } There are two types of setting levers. Select the suitable setting lever by referring to the shapes in the photograph.
 ☆383 421 }
 If the combination of the setting lever and case is unknown, check the case number and refer to "SEIKO Casing Parts Catalogue" to choose an appropriate setting lever.

Day star with dial disk

☆470 424(English-Spanish, black figures on white background)
 Used when both the crown and the calendar frame are located at 3 o'clock position.
 If any other type of day star with dial disk is required, specify the number printed on the disk.

Date dial

☆801 274(Black figures on white background) } Used when both the crown and the calendar frame are located at 3 o'clock position.
 ☆801 275(White figures on black background) }
 ☆801 276(Black figures on white background) } Used when the crown are located at 3 o'clock position and the calendar frame at 6 o'clock position.
 ☆801 277(White figures on black background) }
 If any other type of date dial is required, specify ① Cal. No. ② Jewels ③ The crown position ④ The calendar frame position and ⑤ Dial No.

Date dial guard



☆808 421 The date dial guard designated by the same parts number may have different types of shape, but they can be used in common.

Holding ring for dial

☆884 420 } The type of holding ring for dial is determined based on design of cases and dials.
 ☆884 421 } If the shape of holding ring for dial is different from the photograph, check the case number and refer to "SEIKO Casing Parts Catalogue" to choose a corresponding holding ring for dial.
 ☆884 422 }
 ☆884 423 }

Tube for barrel & train wheel bridge screw, Tube for balance cock screw, Tube for rocking seat for idle wheel, Tube for center wheel bridge screw (A), Tube for pallet cock screw (B).

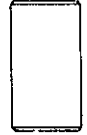
There are two different types as specified below
 Combination

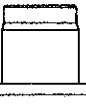
Type	Tube for barrel & train wheel bridge screw Tube for balance cock screw Tube for rocking seat for idle wheel	Tube for center wheel bridge screw (A) Tube for pallet cock screw (B)
a	 ☆017 253	 ☆017 254
b	 ☆017 631	 ☆017 633

4206A

4206A Calendar Mechanism

1) SPECIFICATIONS

- Casing diameter $\phi 17.2\text{mm}$
- Height 5.5mm
- Vibrations per hour 21,600 times/hour
- Automatic winding (with auxiliary hand winding)
- Calendar mechanism (Day and date, bilingual changeover system for the day of the week, instant day and date setting)

2) FEATURES

- This is a ladies' watch with a variety of functions. It has a thin movement which allows for its diversified development of various designs.
- Easy-to-use day and date setting device
Day and Date can be set simply by turning the crown clockwise or counterclockwise at the first click and also bilingual changeover for the day of the week can be done instantly.

3) DISASSEMBLING AND REASSEMBLING

Disassembling procedures Fig.: ① → ⑤⑥

Reassembling procedures Fig.: ⑤⑥ → ①

4) LUBRICATING

The following marks indicate the types of oil, quantities of oil to be applied and the lubricating portions.

• Type of oil

- Moebius A
- SEIKO Watch oil S-6
- SEIKO Watch oil S-4
- Moebius V

• Oil quantity

- Liberal quantity
- Normal quantity
- Extremely small quantity

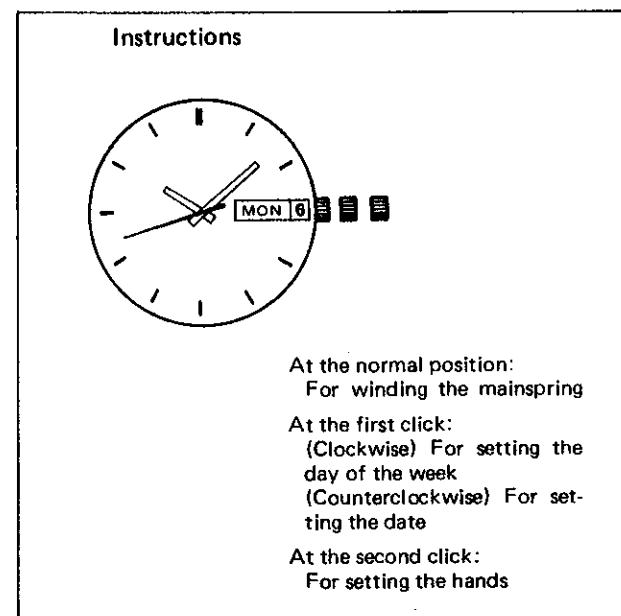
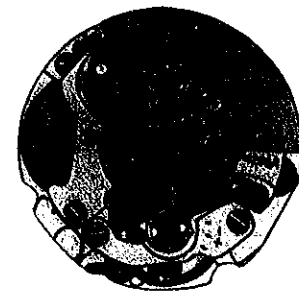

• Disassembling and reassembling of the dial

There are dial leg holders on two places (arrow-marked portions) of the movement. Turn the dial leg holder about 90 degrees and then disassemble or reassemble the dial.

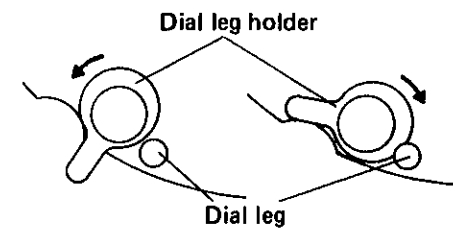
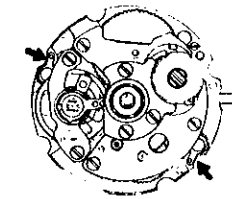

[Disassembling]

[Reassembling]

• Snap for day star with dial disk

How to disassemble
Put the tip of a screwdriver into the groove of the snap for day star with dial disk and pry it up.

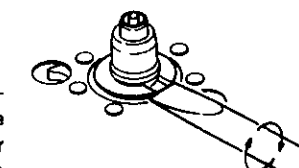

How to reassemble
Hold the snap for day star with dial disk with tweezers in its slot in line with the center axis and push it down.

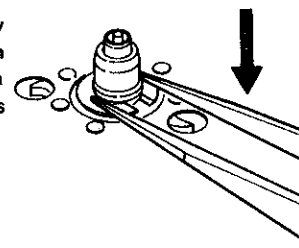

• Date dial guard

When reassembling the date dial guard, set the hole of the date dial guard to the guide pin of the date jumper (arrow marked A) first. Then put the protrusion of the day-date collector finger into the hole on the tip of spring portion of the date dial guard (arrow marked B) for reassembling.

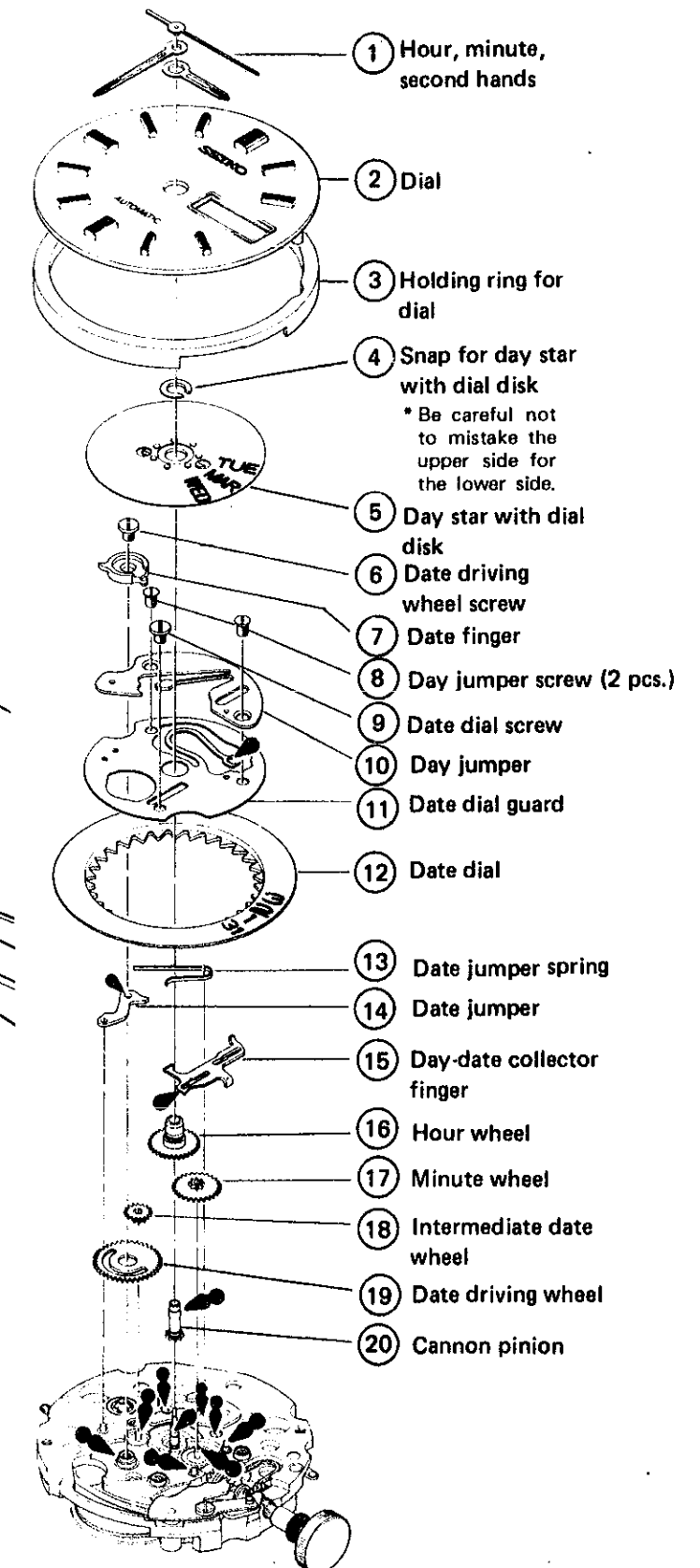
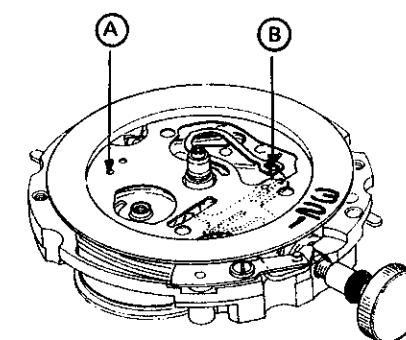

4206A Automatic Winding, Escapement, and Governor Mechanism

• How to set the pawl lever with jewel

Set it to the ball-bearing for oscillating weight after lubricating the eccentric pin on the ball-bearing for oscillating weight. Then put the ball-bearing for oscillating weight on the barrel and train wheel bridge and widen the pawl lever with jewel softly with tweezers to engage it with the transmission wheel. (Be careful not to widen the pawl lever with jewel too much because it causes the pawl lever with jewel to break or become deformed.)

Ball-bearing for oscillating weight

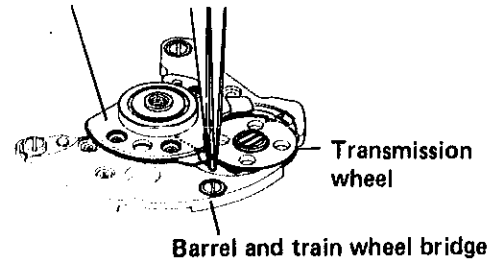

• How to unwind the mainspring

Unwind the mainspring as shown in the illustration below before disassembling the pallet cock.

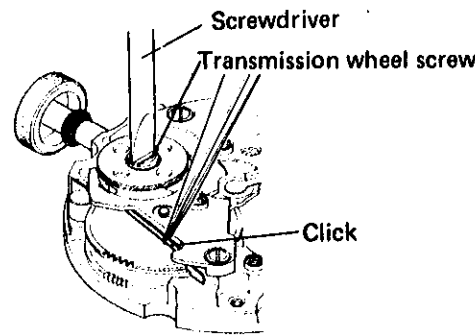

Apply a screwdriver to the transmission wheel screw and turn it counterclockwise a little. The click comes off from the ratchet wheel. Then unwind the mainspring by turning the transmission wheel screw clockwise slowly after pulling out the click from the ratchet wheel with tweezers.

• Balance cock washer

Balance cock washer is for adjusting the end shake of balance complete with stud.

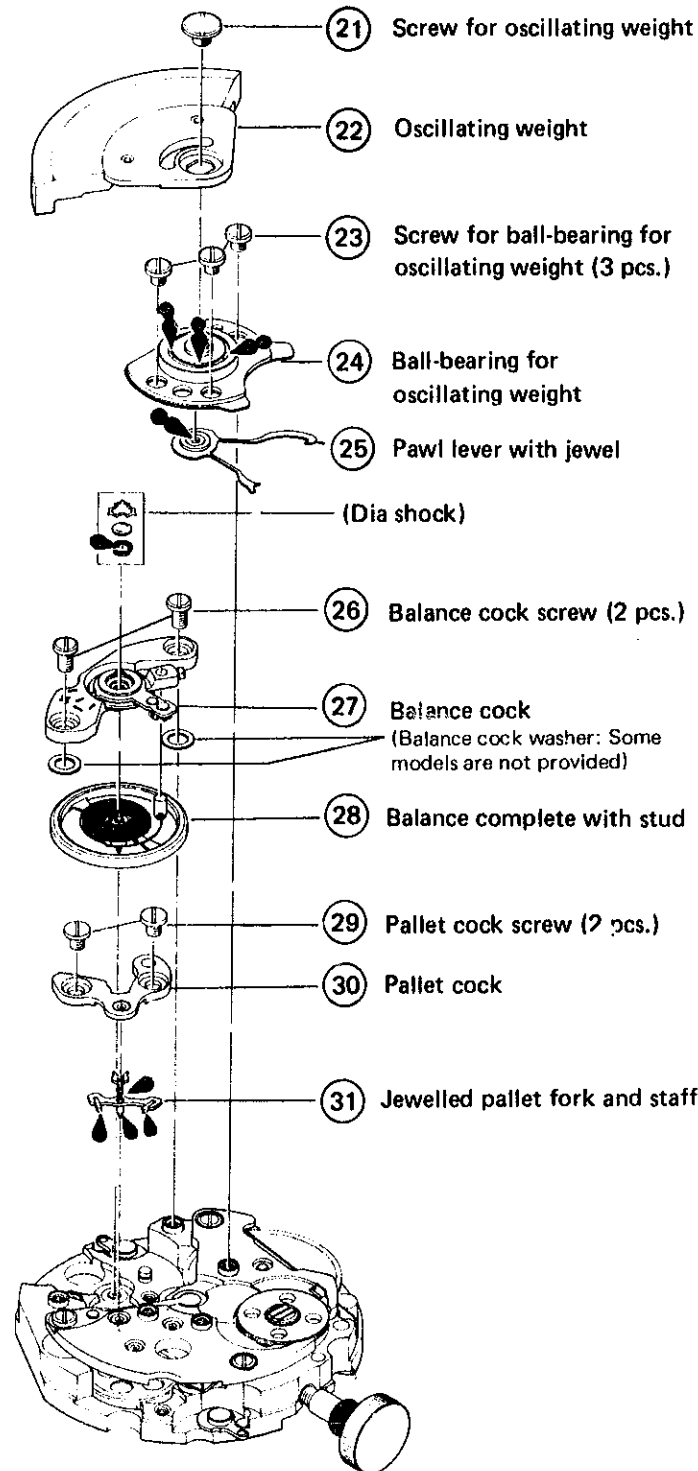

4206A Gear Train Mechanism

• Transmission wheel

How to disassemble and reassemble
When disassembling the transmission wheel from barrel and train wheel bridge, put tweezers in the holes of the transmission wheel as shown in the illustration so as not to turn the transmission wheel, then loosen the transmission wheel screw by turning it clockwise. When reassembling, use tweezers in the same way so as not to turn the transmission wheel to tighten the screw by turning it counterclockwise.

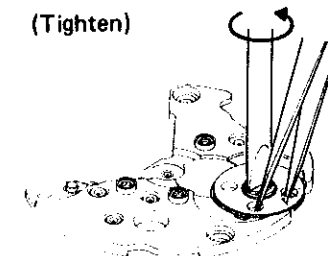
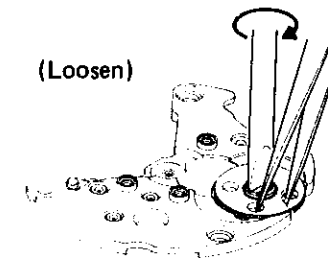

Lubricating

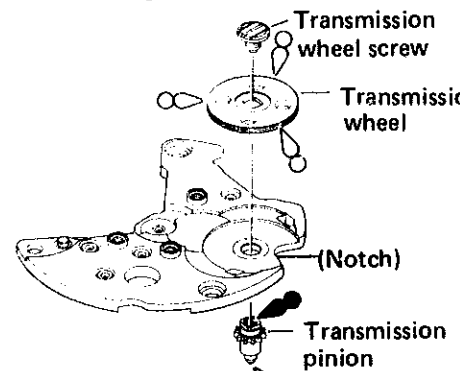

• Sliding crown wheel spring

Reassemble the sliding crown wheel spring so that the tip of it touches the side of the sliding crown wheel.

Sliding crown wheel spring

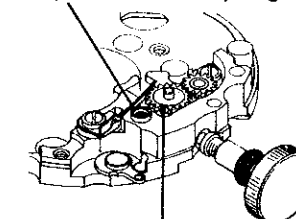

Sliding crown wheel

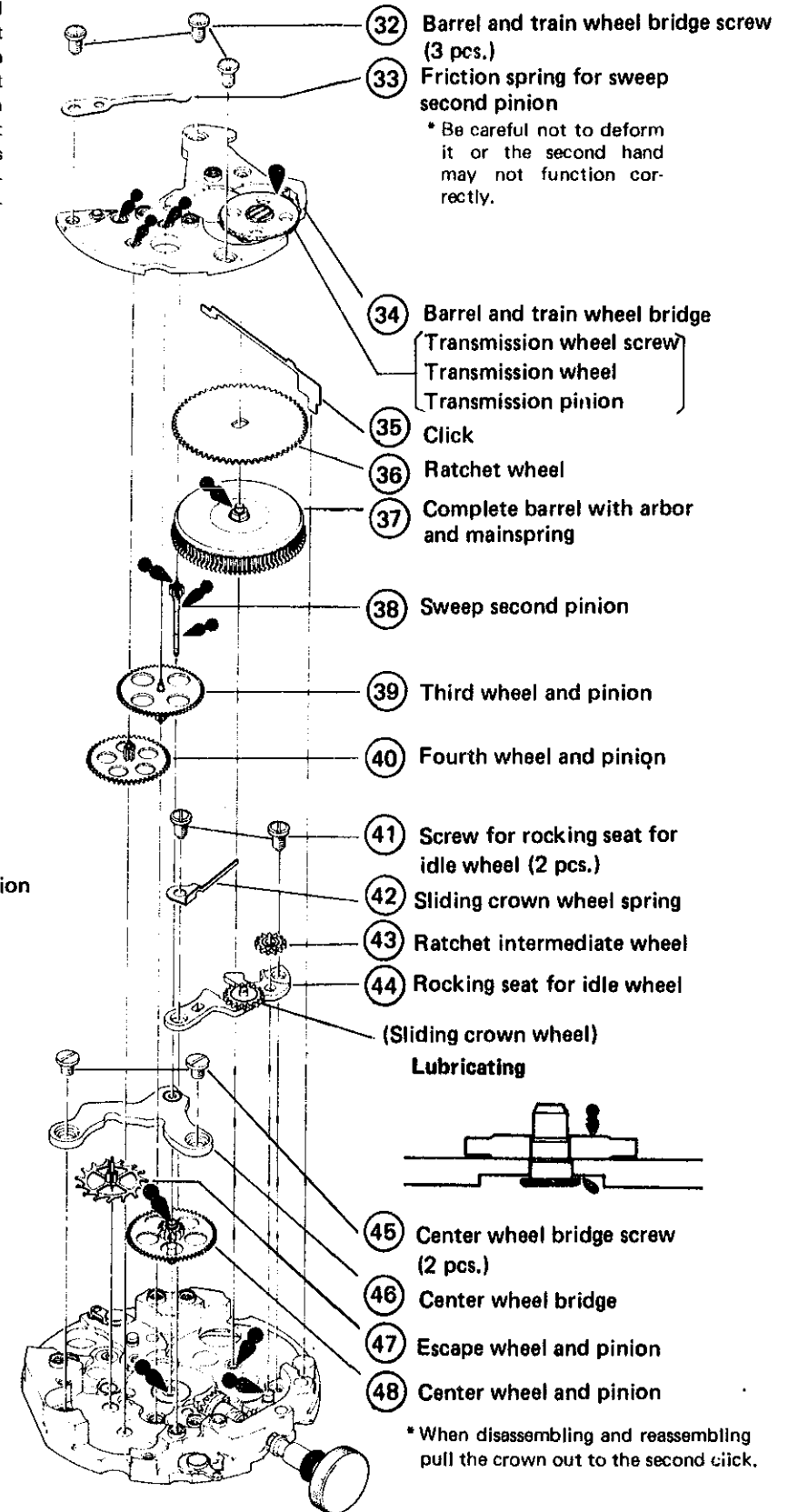

* When disassembling and reassembling pull the crown out to the second click.

4206A Setting Mechanism

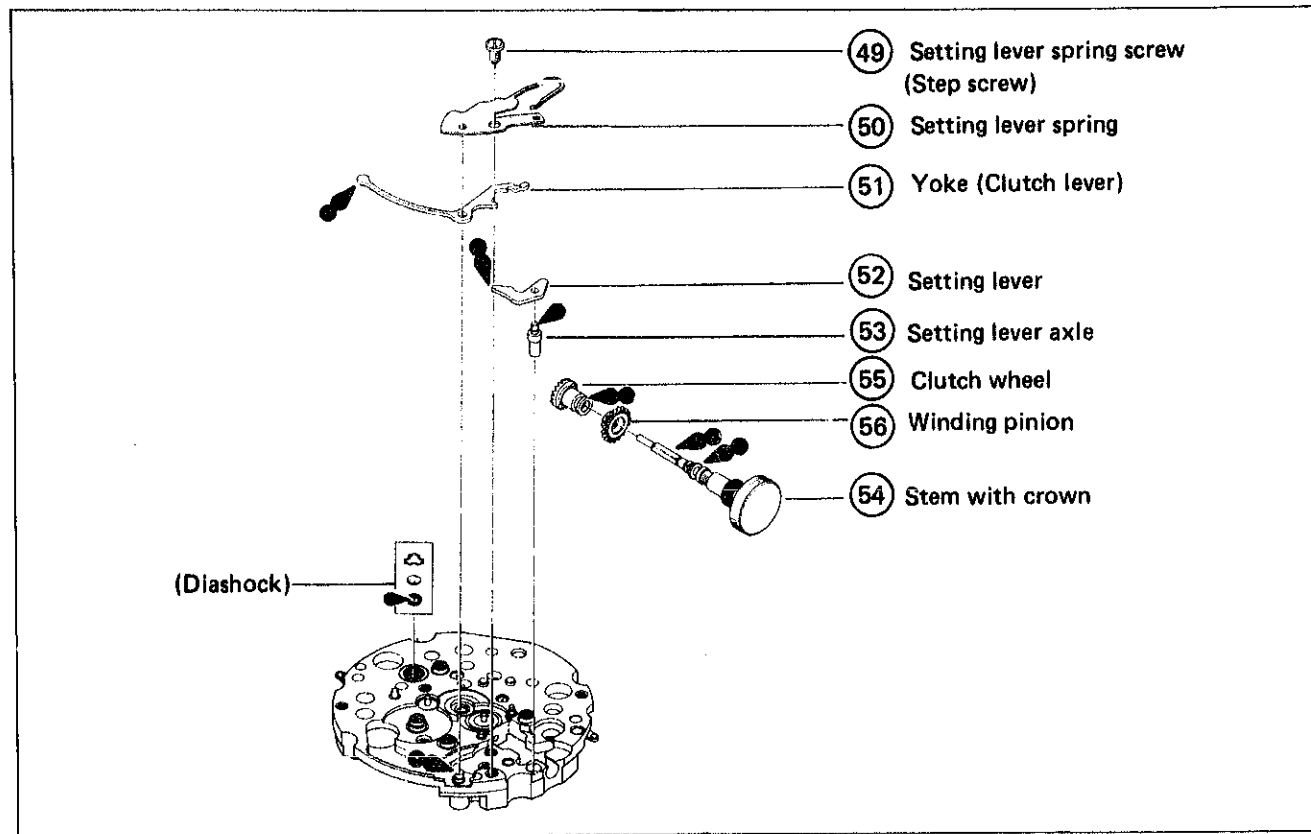

The mainspring of this watch can be wound by operating the crown as well as the automatic winding mechanism. When the crown is turned clockwise, rotatory power is transmitted in the following order and the mainspring will be wound eventually.

Winding pinion → Sliding crown wheel → Intermediate ratchet wheel → Transmission pinion → Ratchet wheel
 If the crown is turned counterclockwise, the mainspring won't be wound because the sliding crown wheel will part from the intermediate ratchet wheel.

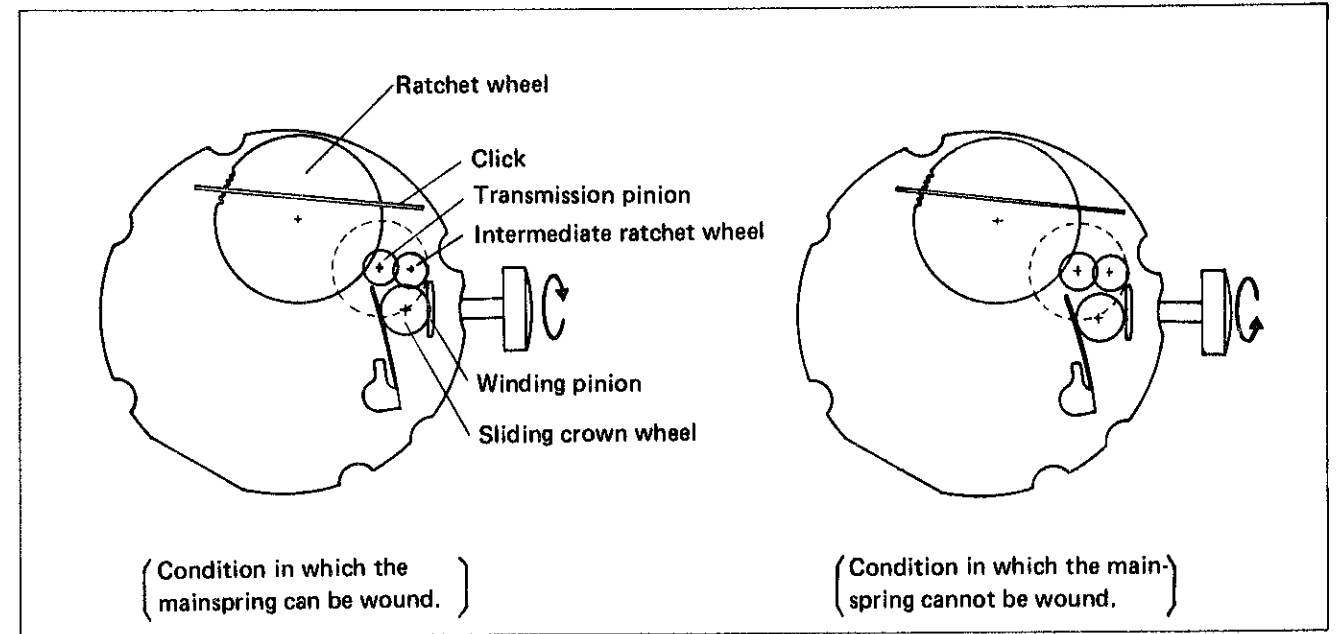

OPERATING INSTRUCTIONS FOR AUTOMATIC WINDUP MECHANISM

1. Automatic winding mechanism

Cal. 4206A is equipped with an automatic winding mechanism of pawl lever type which is of fine assembly and winding efficiency.

The pawl lever with jewel is attached to the eccentric pin on the ball-bearing for oscillating weight which is under the oscillating weight. Therefore, when the oscillating weight oscillates around to left or right, pawl lever with jewel moves backward and forward against the transmission wheel. The end of the pawl lever with jewel is divided into two points and the tip of the finger engages with the transmission wheel cog.

The transmission wheel cog takes the ratchet shape and the transmission wheel turns around in one direction by operation of the pawl lever with jewel.

Rotation of the transmission wheel is transmitted to the ratchet wheel which is engaged with the transmission wheel and eventually the mainspring will be wound.

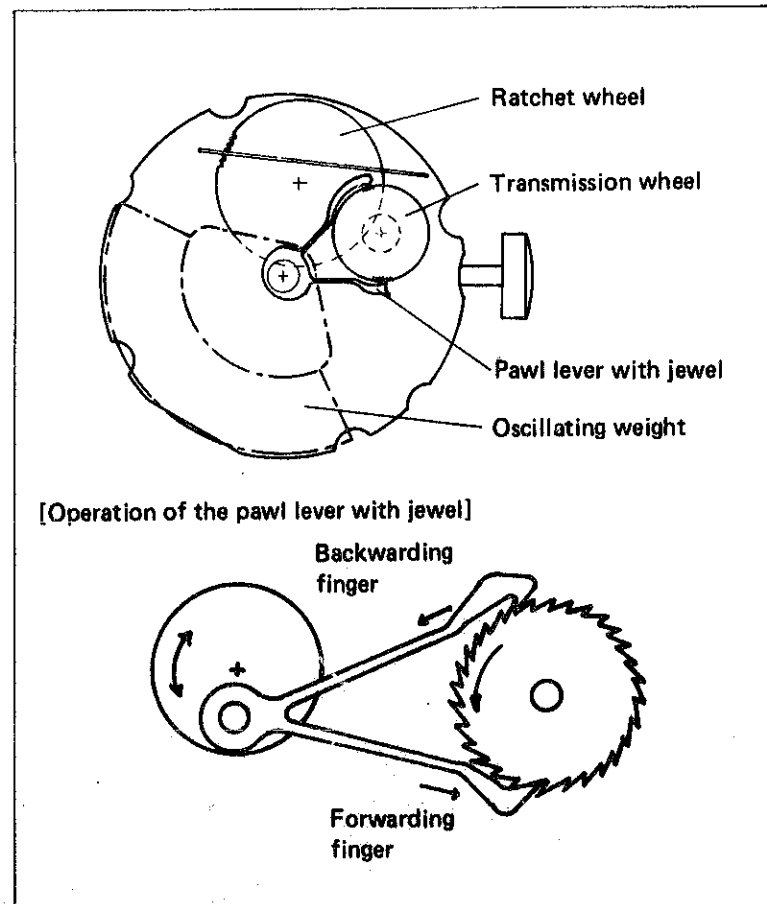

4206A Checking for Automatic Windup Mechanism

When there is any defect with the automatic windup mechanism, the mainspring cannot be wound and the watch itself stops functioning. In this case, check the following items:

- Engagement condition of pawl lever with jewel and transmission wheel.

Confirm if the pawl lever with jewel engages with the cog of the transmission wheel. If the cogs are out of engagement, repair it through the procedures below.

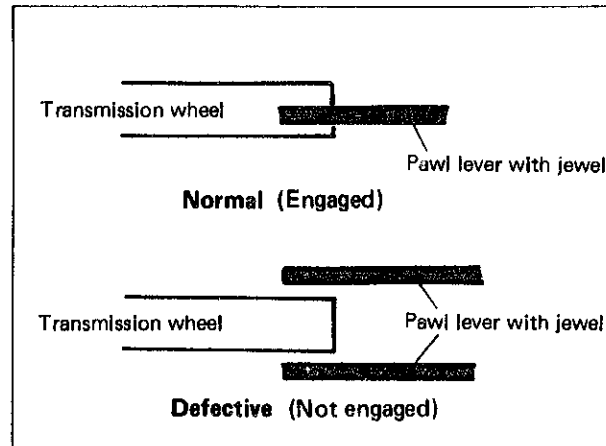

Procedure 1

Turn over the ball-bearing for oscillating weight and put the pawl lever with jewel on it. (Be careful not to mistake the surface for the back side.)

Procedure 2

Hold the pawl lever with jewel softly with a finger as shown in the illustration on the right while lifting up one end of the pawl lever with jewel with tweezers lightly to bend it to about the thickness of the pawl lever with jewel to engage it with the transmission wheel.

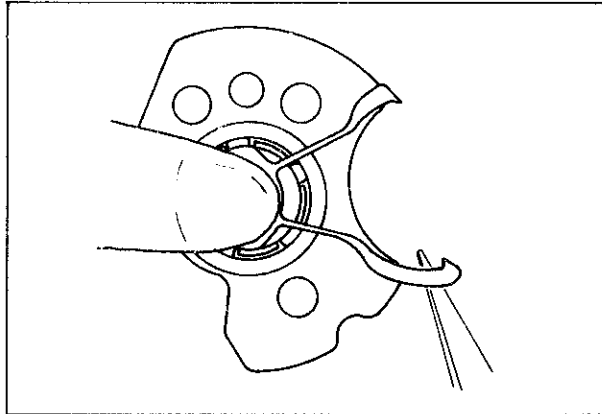

Procedure 3

Confirm the engagement condition of the pawl lever with jewel and the transmission wheel after putting the ball-bearing for oscillating weight and pawl lever with jewel in the barrel and train wheel bridge.

Be careful not to bend the pawl lever with jewel too much or it may touch the barrel and train wheel bridge. If the pawl lever with jewel is bent too much, replace it with a new one.

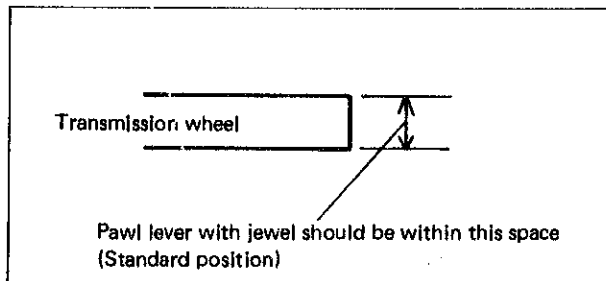

Procedure 4

Confirm that the cogs of the transmission wheel do not get out of engagement when the oscillating weight is put in and turned around to the right or left.

* Replace the pawl lever with jewel with a new one if it still does not function correctly after the repair.