

SEIKO

QUARTZ

Cal. 2E20A

**PARTS
CATALOGUE**

Cal. 2E20A



125 202



141 202



231 202



241 202



261 202



☆270 202



☆271 202



281 202



282 202



☆351 205



383 202



384 202



388 202



491 202



493 201



4000 208



4002 202



4146 202



4219 210



4225 210



4239 202



4270 210



4408 208



4408 209



4408 210



4450 202



4457 201



☆SEIKO TR521SW



012 038



012 039



012 792



012 824



017 779



032 015



032 016



032 017



032 018

3/1

Cal. 2E20A

Characteristics

Casing diameter : ϕ 15.1 mm
 Maximum height : 2.2 mm without battery
 Jewels : 2 j
 Frequency of quartz crystal oscillator : 32,768 Hz (Hz=Hertz Cycles per second)
 Driving system : Step motor (2 poles)
 Regulation system : Regulating switch lever
 Train wheel setting

PART NO.	PART NAME	PART NO.	PART NAME
125 202	Train wheel bridge		
141 202	Fourth wheel bridge		
231 202	Third wheel & pinion		
241 202	Fourth wheel & pinion		
261 202	Minute wheel		
☆ 270 202	Center minute wheel		
☆270 203			
☆270 204			
☆ 271 202	Hour wheel		
☆271 203			
☆271 204			
281 202	Setting wheel		
282 202	Clutch wheel		
☆ 351 205	Winding stem		
☆351 206			
☆351 207			
383 202	Setting lever		
384 202	Yoke		
388 202	Setting lever spring		
491 202	Dial washer		
493 201	Hour wheel ring (Thickness 0.03 mm)		
493 202	Hour wheel ring (Thickness 0.05 mm)		
493 203	Hour wheel ring (Thickness 0.07 mm)		
4000 208	Circuit block		
4002 202	Coil block		
4146 202	Step rotor		
4219 210	Battery connection insulator		
4225 210	Battery clamp		
4239 202	Rotor stator		
4270 210	Battery connection (-)		
4408 208	Circuit block spacer (A)		
4408 209	Circuit block spacer (B) connection		
4408 210	Battery connection (-) spacer		
4450 202	Regulating switch lever		
4457 201	Circuit block cover		
011 334	Lower hole jewel for step rotor		
011 566	Upper hole jewel for step rotor		
012 038	Train wheel bridge screw		
012 039	Screw for battery clamp		
012 792	Circuit block screw		
012 824	Setting lever spring screw		
017 779	Lower bush for center minute wheel		
032 015	Tube for train wheel bridge (A)		
032 016	Tube for train wheel bridge (B)		
032 017	Tube for coil block		
032 018	Tube for circuit block		
☆SEIKO TR521SW	Silver (II) oxide battery		







☆⇨ Please see remarks on the reverse page.
 Part numbers in light letters are not shown in photos.

Cal. 2E20A

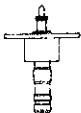
Remarks :

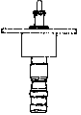
Center minute wheel, Hour wheel

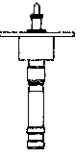
There are three different types as specified below.
Combination :

Type	Center minute wheel	Hour wheel
a.	 ☆270 202	 ☆271 202
b.	 ☆270 203	 ☆271 203
c.	 ☆270 204	 ☆271 204

Winding stem

- ☆351 205
 - ☆351 206
 - ☆351 207
 - ☆351 208
- Refer to the photograph on the front page.
If the combination of the winding stem and case is unknown, check the case number and refer to "SEIKO Quartz Casing Parts Catalogue" to choose a corresponding winding stem.

Battery

- ☆SEIKO TR521SW.....The substitutive battery might be added to the applied battery in the future.
In that case please refer to separate "BATTERY LIST FOR SEIKO QUARTZ WATCHES".

TECHNICAL GUIDE

SEIKO
QUARTZ

CAL. 2E20A

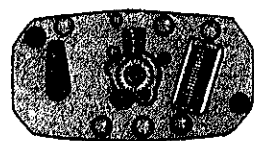

CONTENTS

I. SPECIFICATIONS	1
II. STRUCTURE OF THE CIRCUIT BLOCK	1
III. DISASSEMBLING, REASSEMBLING, AND LUBRICATING	2
1. Hour and minute hands ~ Hour wheel	2
2. Battery clamp screw ~ Coil block	3
3. Circuit block spacer B ~ Rotor stator	4
IV. CHECKING AND ADJUSTMENT	5
• Check output signal	5
• Check hands setting condition	5
• Check battery voltage	5
• Check battery conductivity	5
• Check conductivity of circuit block	5
• Check coil block	5
• Check gear train mechanism	5
• Check reset and train wheel setting condition	6
• Check current consumption	7
• Check accuracy	7
• Check appearance and functioning	7

I. SPECIFICATIONS

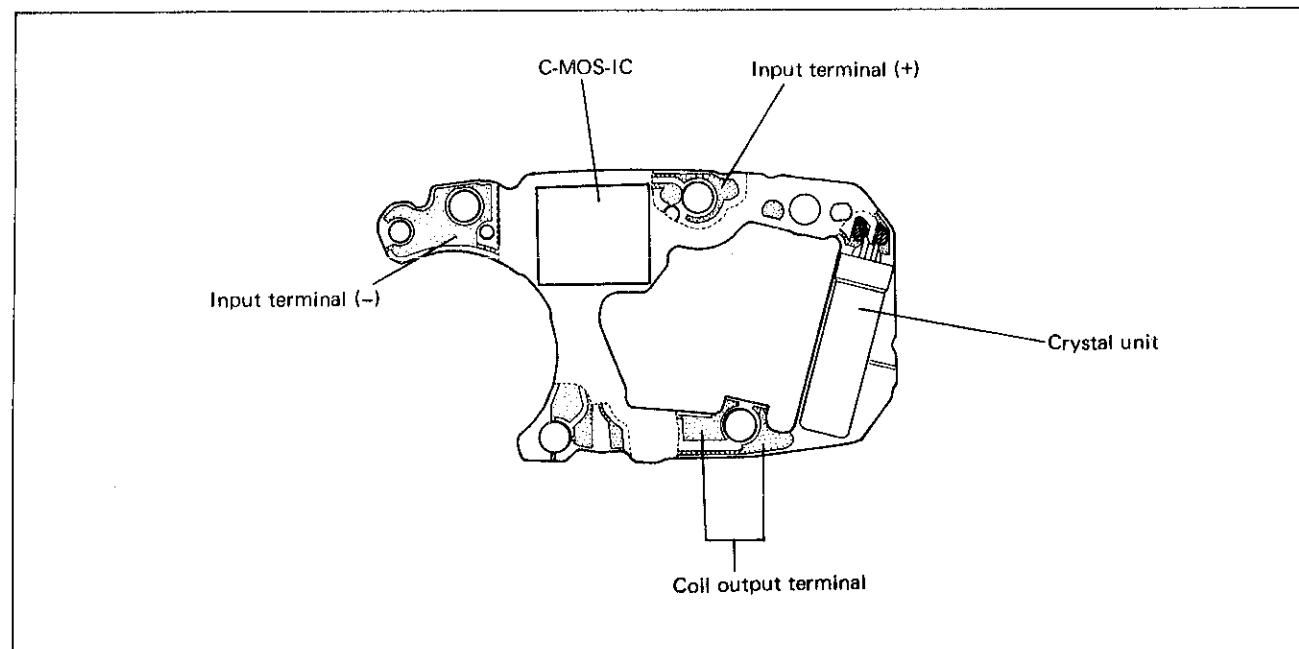

Cal. No.		2E20A
Item		
Time indication	2 hands (Moves at every 20 seconds)	
Driving system	Step motor (Fixed-width pulse system)	
Additional mechanism	<ul style="list-style-type: none"> • Electronic circuit reset switch • Train wheel setting device 	
Loss/gain	Monthly rate at normal temperature range: less than 15 seconds	
Movement size	Outside diameter	15.5mm between 6 o'clock and 12 o'clock sides 8.4mm between 3 o'clock and 9 o'clock sides
	Casing diameter	φ15.1mm
	Height	2.2mm
Regulation system	Rotary step switch (1 step = approx. 0.26 sec./day)	
Measuring gate by quartz tester	Use the 10-second gate.	
Battery	SEIKO (SEIZAIKEN) TR521SW Battery life is approximately 3 years. Voltage: 1.55V	
Jewels	2 jewels	

II. STRUCTURE OF THE CIRCUIT BLOCK

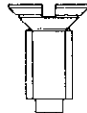
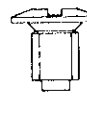

III. DISASSEMBLING, REASSEMBLING, AND LUBRICATING

List of the screws used

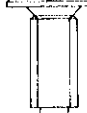



Shape	Part No.	Name	Shape	Part No.	Name
	012 792	Circuit block screw (5 pcs.)		012 038	Train wheel bridge screw (1 pc.)
	012 824	Setting lever spring screw (1 pc.)		012 039	Battery clamp screw* (1 pc.)

*The battery clamp screw is not used in some models.

Disassembling procedures Figs.: ① → ③④

Reassembling procedures Figs.: ③④ → ①

Lubricating **Types of oil:** **Oil quantity:**

 Moebius A  Normal quantity
 SEIKO Watch Oil S-6  Extremely small

• Use the universal movement holder for disassembling and reassembling.

1. Hour and minute hands ~ Hour wheel

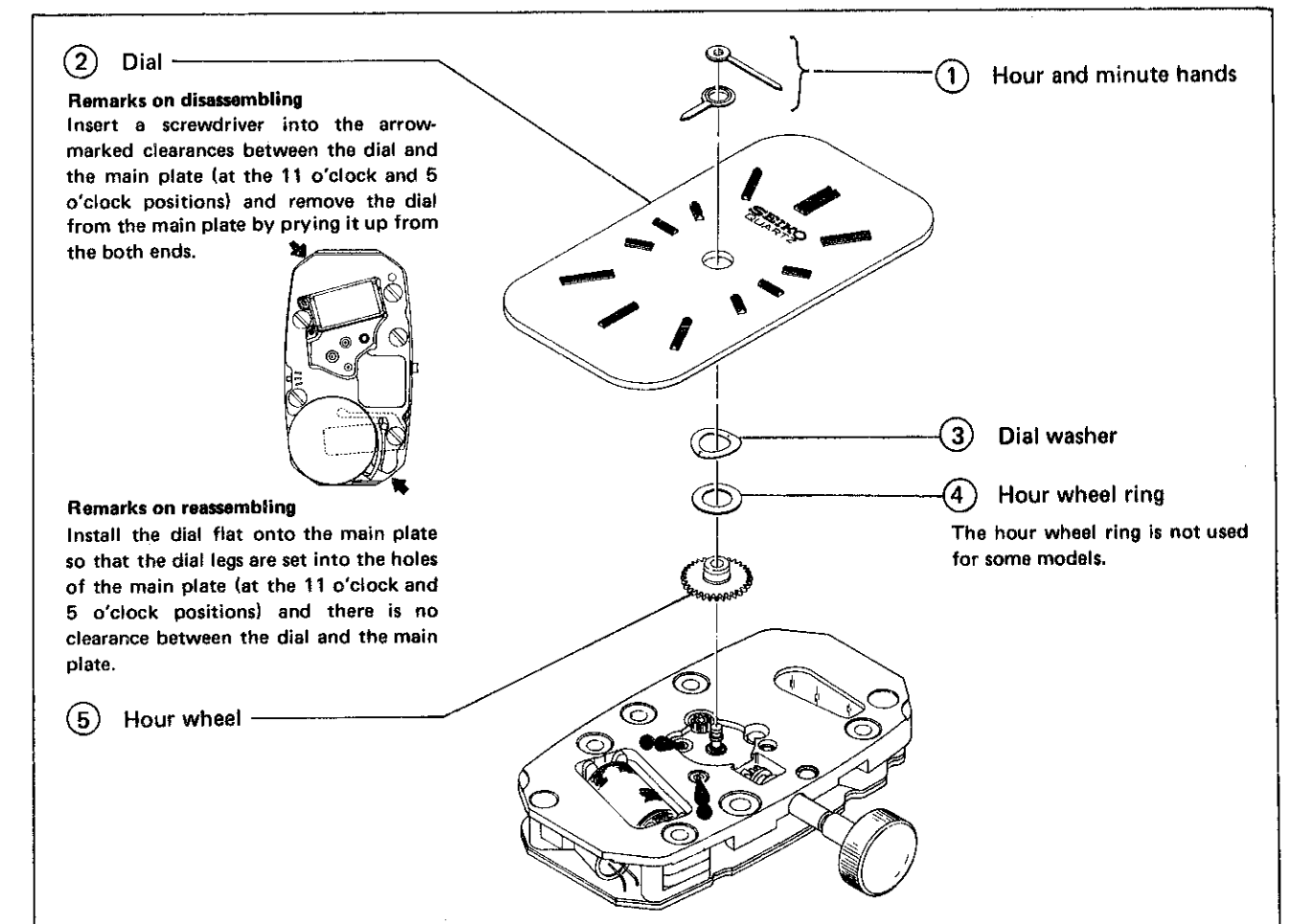

2. Battery clamp screw ~ Coil block

⑥ Battery clamp screw

⑦ Battery clamp

The battery clamp is not used in some models.
When reassembling it, fix it to the circuit block cover by tightening the battery clamp screw.

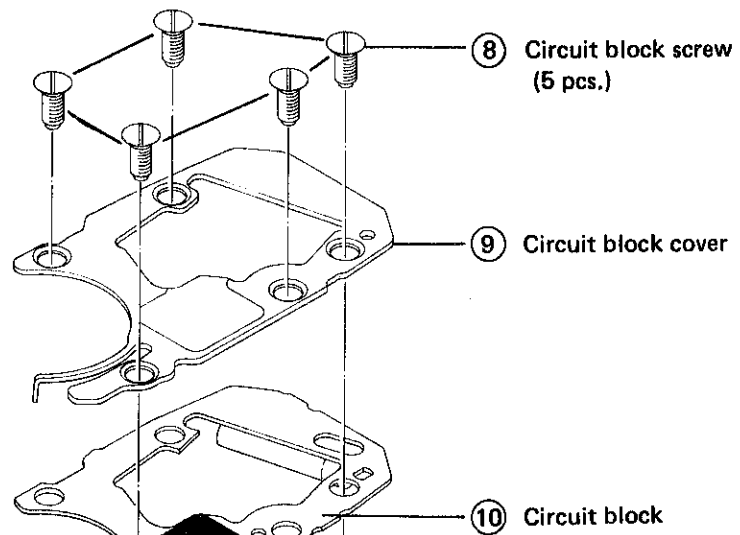
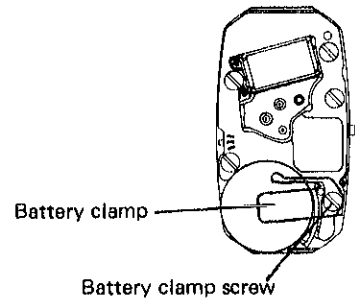

⑧ Circuit block screw (5 pcs.)

⑨ Circuit block cover

⑩ Circuit block

⑪ Battery connection (-)

Remarks on reassembling
Set the tip of the battery connection (-) between the sheets of a battery connection insulator which is folded.

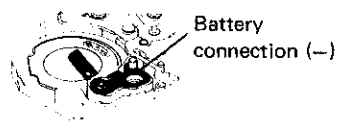

⑫ Battery connection insulator

The battery connection insulator is folded as below.

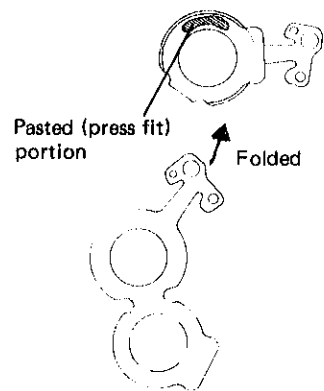

⑬ Battery connection (-) spacer

⑭ Circuit block spacer A

⑮ Coil block

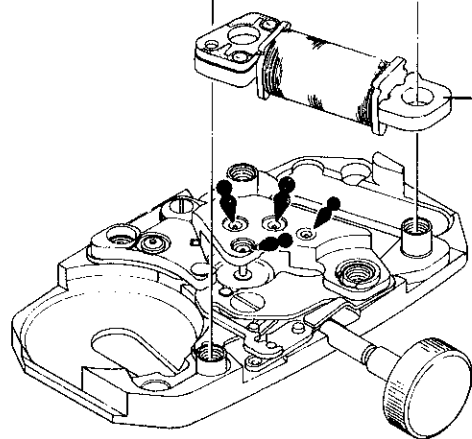

3. Circuit block spacer B ~ Rotor stator

Setting position of the gear train

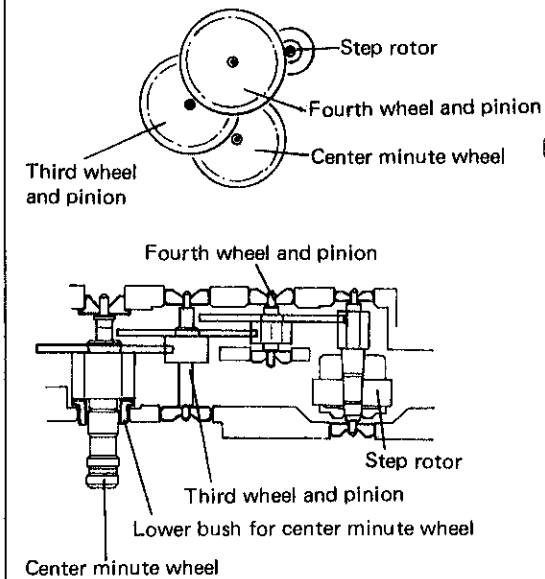

⑯ Circuit block spacer B

Be careful not to lose the reset pin, as it comes off.

Remarks on reassembling
Push the crown in to the normal position and install the circuit block spacer so that its reset pin is set into the hole of the fourth wheel bridge.

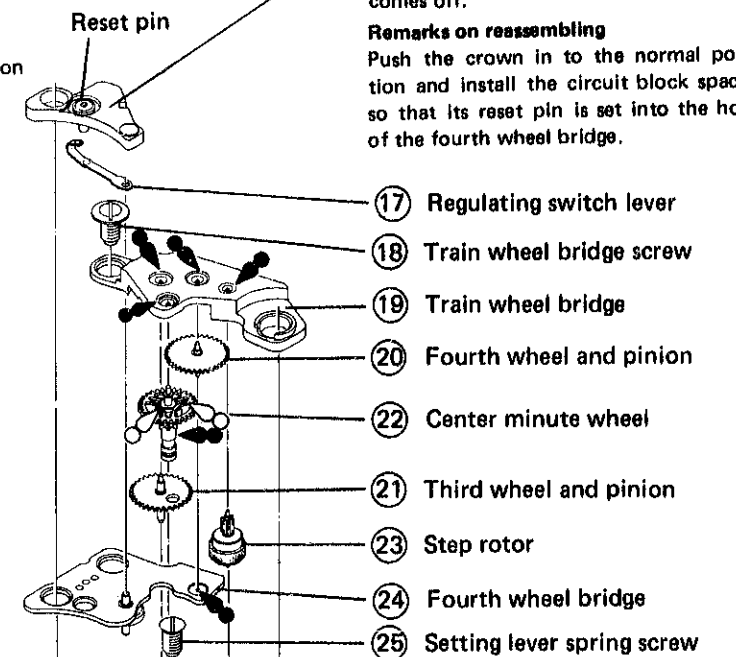

⑰ Regulating switch lever

⑱ Train wheel bridge screw

⑲ Train wheel bridge

⑳ Fourth wheel and pinion

㉒ Center minute wheel

㉑ Third wheel and pinion

㉓ Step rotor

㉔ Fourth wheel bridge

㉕ Setting lever spring screw

⑳ Setting lever spring

Remarks on reassembling

Set the bigger hole of the setting lever spring to the tube of the main plate (oblique-lined) and slide the setting lever spring in the direction indicated by the arrow so that the pins (A) and (B) of the main plate are set in position as illustrated below.
Then, tighten the setting lever spring screw.

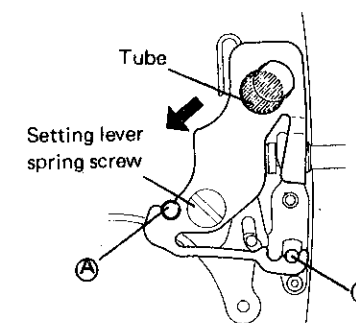

㉗ Setting wheel

㉘ Yoke

㉙ Setting lever

㉚ Clutch wheel

㉛ Stem with crown

㉜ Minute wheel

㉝ Lower bush for center minute wheel

㉞ Rotor stator

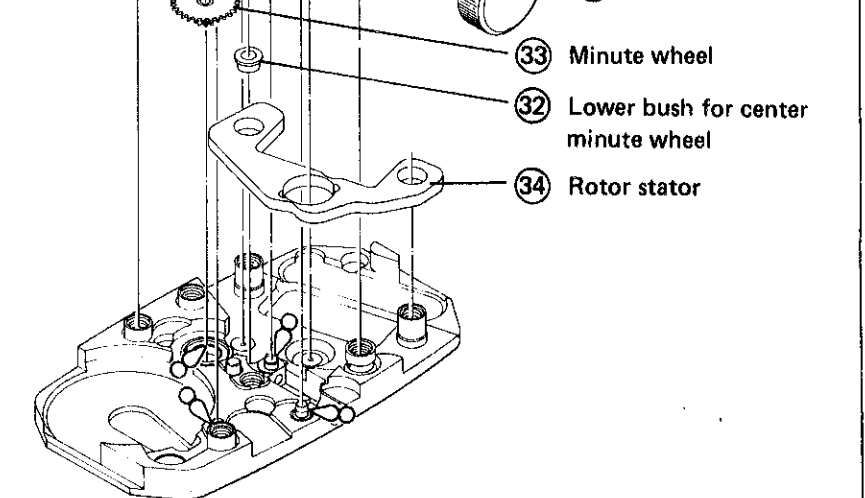

IV. CHECKING AND ADJUSTMENT

- The explanation here is only for the particular points of Cal. 2E20A.
Refer to the "TECHNICAL GUIDE, GENERAL INSTRUCTION" for SEIKO Analogue Quartz for details.

Procedure	
CHECK OUTPUT SIGNAL	<p>Range to be used: 10-second gate</p> <p>Result: Normal : Input indicator blinks every 10 seconds. Defective : Input indicator does not blink every 10 seconds.</p>
CHECK HANDS SETTING CONDITION	
CHECK BATTERY VOLTAGE	<p>Use the Digital Multi-Tester S-840. Mode to be used: DC V</p> <p>Result: Normal : More than 1.57V Defective : Less than 1.57V</p> <p>• Before starting measurement, short-circuit the probes to see that the Digital Multi-Tester displays "AUTO 00.0mV" or "AUTO 00.1mV".</p>
CHECK BATTERY CONDUCTIVITY	
CHECK CONDUCTIVITY OF CIRCUIT BLOCK	
CHECK COIL BLOCK	<p>Use the Digital Multi-Tester S-840. Range to be used: Ω</p> <p>Result: Normal : $1.4K\Omega \sim 2.0K\Omega$ Defective : $\left\{ \begin{array}{l} \text{Less than } 1.4K\Omega \\ \text{(Short circuit)} \\ \text{More than } 2.0K\Omega \\ \text{(Broken wire)} \end{array} \right.$</p> <p>• Before starting measurement, short-circuit the probes to see that the Digital Multi-Tester displays "AUTO 00.2 ~ 00.4 Ω" with the buzzer beeping.</p>
CHECK GEAR TRAIN MECHANISM	

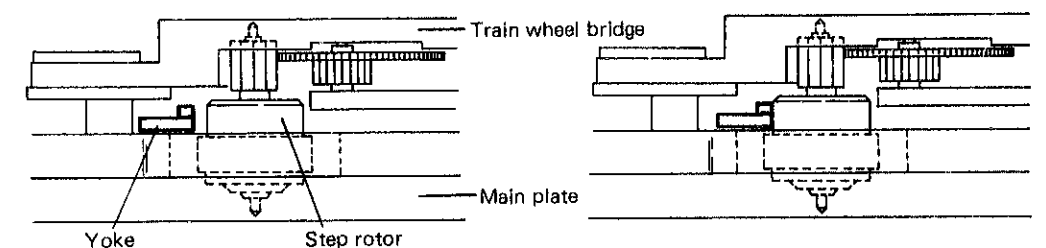
Procedure	
CHECK RESET AND TRAIN WHEEL SETTING CONDITION	
<p>Check to see if the step rotor stops promptly when the crown is pulled out completely and if it starts exactly 20 seconds after the crown is pushed in back to the normal position.</p> <p>(1) Check train wheel setting condition. With the circuit block and the coil block removed, check the clearance between the yoke and the step rotor by looking at it from the side where the coil block used to be installed.</p>	
<p style="text-align: center;">Crown : Normal position Crown : First click position</p> 	
<p>(2) Check reset condition. Check output signal with the circuit block, coil block, and battery installed.</p>	
<ul style="list-style-type: none"> • With the crown at the normal position 	<p>Result: Normal : Input indicator blinks every 10 seconds. Defective : Input indicator does not blink every 10 seconds. Replace the yoke with a new one.</p>
<ul style="list-style-type: none"> • With the crown at the first click position 	<p>Result: Normal : Input indicator does not blink every 10 seconds. Defective : Input indicator blinks every 10 seconds. Replace the yoke with a new one.</p>

Procedure

CHECK CURRENT CONSUMPTION

Caution:

- Do not check current consumption under an incandescent lamp since strong light may cause a watch to consume excess current.
- Be sure to protect the MOS-IC unit from light with a black paper, etc. while measuring.

Use the Digital Multi-Tester S-840.

Mode to be used: μA

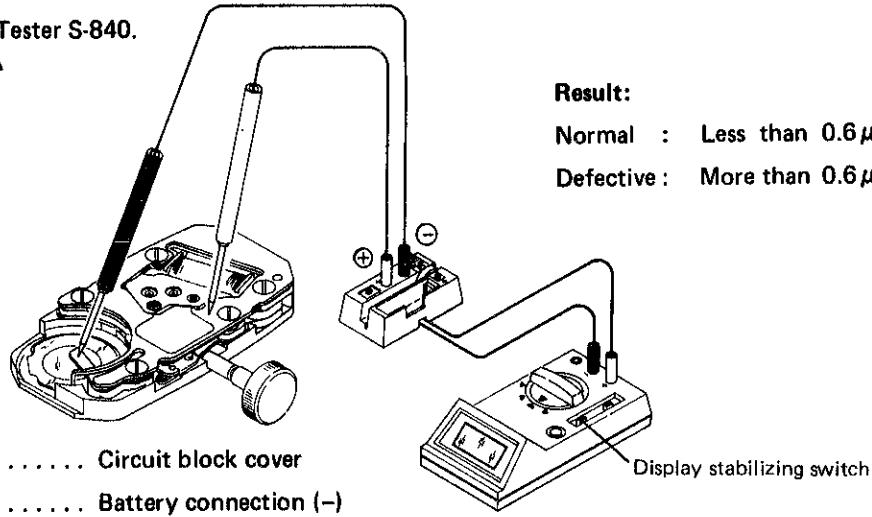

Set the display stabilizing switch of the tester to the "B" position.

When the (+) and (-) probes of the tester are applied as shown in the illustration above, the tester displays a value, indicating that electric current is flowing in the IC.

The value displayed is increased, since the motor driving current flows in the step motor once every 20 seconds. Read a maximum value to judge the current consumption value. (When the display stabilizing switch is set to the "B" position, the tester's value-averaging calculation function works.)

CHECK ACCURACY

Measuring time accuracy

- Use the 10-second gate of the quartz tester.
- Be sure to protect the C-MOS-IC from light with case back or black paper, etc. while measuring.
- Do not measure accuracy under an incandescent lamp, since strong light adversely affects time accuracy.

Adjusting time accuracy

- Hold the regulating switch lever with tweezers as shown in the illustration on the right, and slide it while lightly pressing it toward the main plate.
- Make sure to see that the regulating switch lever is not inclined and corresponds with a graduation.
- The range to be regulated by the regulating switch lever is approximately ± 0.26 sec./day.

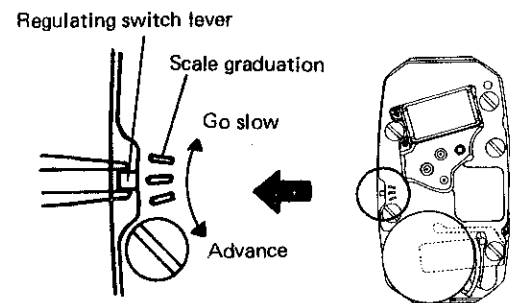

CHECK APPEARANCE AND FUNCTIONING

All procedures of Disassembling, Reassembling, Lubricating, Checking and Adjustment are completed.