

TECHNICAL GUIDE AND PARTS LIST

CAL. Y729A

DIGITAL QUARTZ

CONTENTS

I. SPECIFICATIONS.....	1
II. DISASSEMBLING, REASSEMBLING AND LUBRICATING.....	2
1. Disassembling, reassembling and lubricating of the case.....	2
2. Disassembling and reassembling of the module.....	5
III. CHECKING AND ADJUSTMENT.....	7
1. Guide table for checking and adjustment.....	7
2. Relationship between the segment (Liquid Crystal Panel Electrode) and the C-MOS-LSI output terminal.....	8
3. Procedures for checking and adjustment.....	9
A: Check battery voltage.....	9
• How to check battery electrolyte leakage and repair.....	9
• Check pattern segment checking system.....	10
B: Check contact of C-MOS-LSI ~ liquid crystal panel.....	10
C: Check liquid crystal panel and circuit block.....	11
D: Check current consumption.....	12
E: Check accuracy.....	13
F: Check functioning and adjustment.....	13
G: Check bulb condition.....	13
• How to replace the bulb.....	14
H: Check conductivity of switch components.....	15
IV. PARTS LIST OF MODULE.....	16

I. SPECIFICATIONS

Item	Cal. No.	Y729A
Display medium		Nematic Liquid Crystal, FEM (Field Effect Mode)
Display system		<p>Four-function changeover system with time, stopwatch, counter and time/calendar setting functions.</p> <ul style="list-style-type: none"> ● Time function: Digital display system showing hour, minute, second and day of the week. In the time function, calendar and elapsing time in the stopwatch function are displayed by depressing a button. Calendar: Digital display system showing month, date and day of the week. ● Stopwatch function: 12-hour digital display system showing hour, minute, second and 1/100 second (The 1/100 second measurement is possible up to 20 minutes.) ● Counter function: <ul style="list-style-type: none"> Single..... Counting up to 9999 Twin counter..... Counting up to 99 in two ways ● Time/calendar setting function: Time and calendar can be set to operate at a desired second, minute, hour (with "A" (for A.M.)/"P" (for P.M.) indication), date, month and day of the week.
Additional mechanism		<ul style="list-style-type: none"> ● Illuminating light ● Pattern segment checking system
Crystal oscillator		32,768 Hz (Hz = Hertz..... Cycles per second)
Loss/gain		<p>Loss/gain at normal temperature range</p> <p>Monthly rate: less than 20 seconds</p> <p>(Annual rate: less than 4 minutes)</p>
Casing diameter		φ28.1 mm
Height		4.2 mm without battery
Operational temperature range		-10°C ~ +60°C (14°F ~ 140°F)
Regulation system		Trimmer condenser
Battery power		<p>Silver oxide battery: U.C.C. 392, Sony eveready 392, Maxell SR41W or Toshiba WG3</p> <p>Voltage: 1.55V</p> <p>Battery life: Approx. 1 year</p>
IC (Integrated Circuit)		C-MOS-LSI..... 1 unit

II. DISASSEMBLING, REASSEMBLING AND LUBRICATING

1. Disassembling and reassembling and lubricating of the case

Disassembling procedures Figs.:

① ~ ⑤

Reassembling procedures Figs.:

⑤ ~ ①

Lubricating:

Silicone grease (500,000 c.s.)

Normal quantity 

Glass portion.

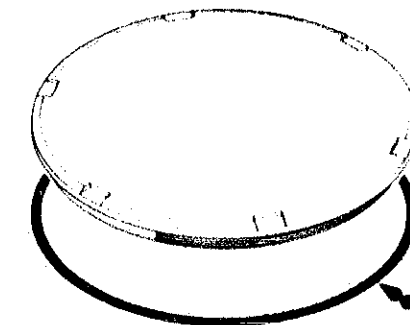
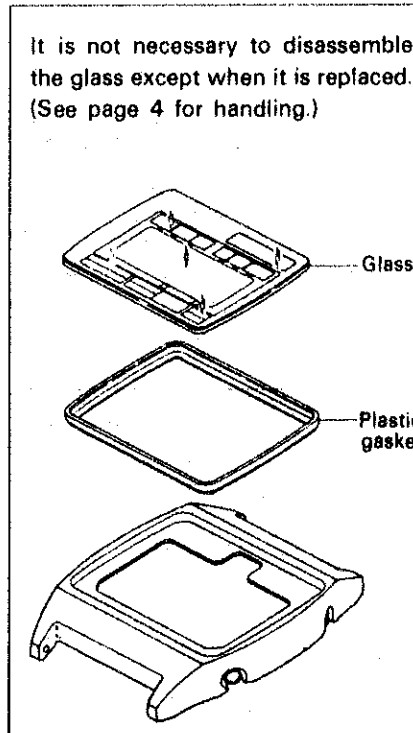

① Case back

② Case back gasket



③ Battery

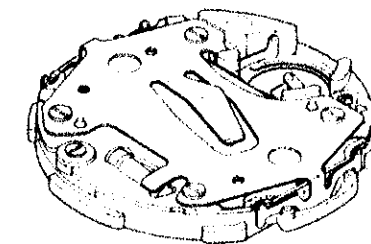

④ Module

(Time adjusting buttons)

It is not necessary to disassemble the time adjusting buttons (4 assemblies) except when they are required to be replaced.

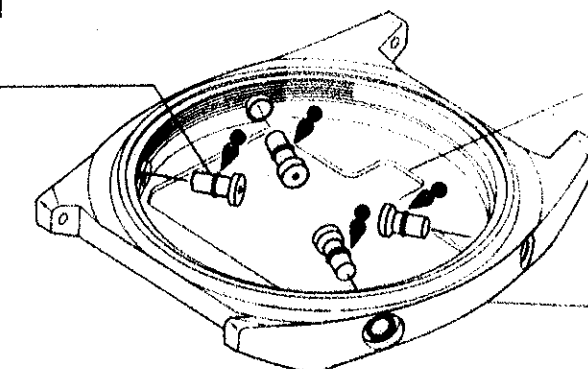

⑤ Case bezel

Remarks for disassembling

④ Module

- Put the tips of the tweezers in a clearance between the liquid crystal panel and the casebezel and pry up the module to take out.

Remarks for reassembling

⑤ Casebezel

- Before reassembling the module, pull out all buttons so that the switch springs do not prevent the module from being inserted.
(Push the buttons from inside with the tips of tweezers.)

④ Module

- As the liquid crystal panel frame is fixed fast to the casebezel, push in the module with fingers.
- Push it in so that it does not catch the buttons.

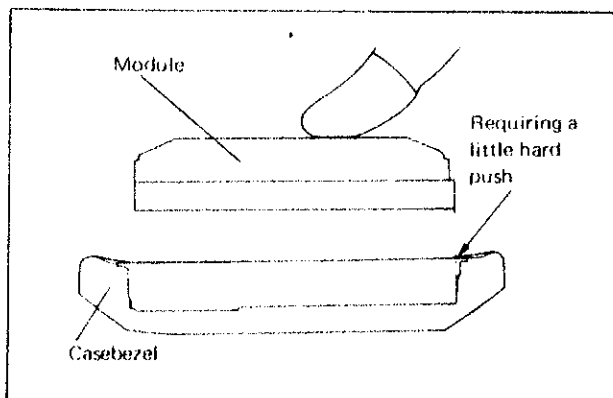
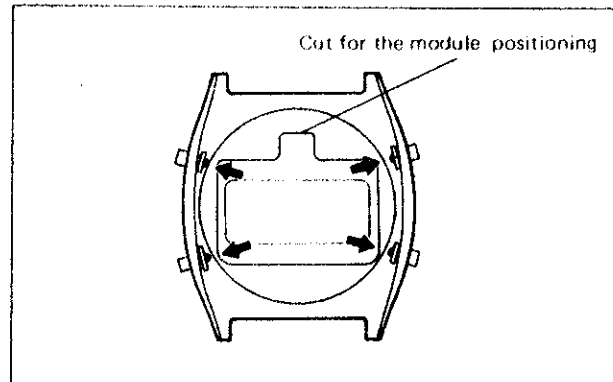
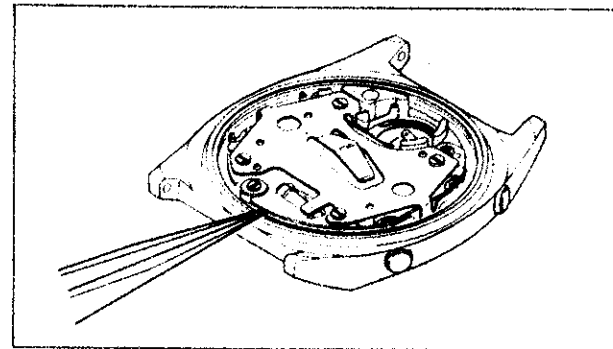

How to replace the glass

(It is not necessary to disassemble the glass except when it is replaced.)

● How to disassemble the glass

- Remove the glass with the tightening tool.
- Inserting disk
- Supporting disk: $\phi 34.0 \sim \phi 35.0$ mm
- Place a vinyl sheet between the glass and the supporting disk as shown in the illustration on the right.
- Push the glass for disassembling with the inserting disk.

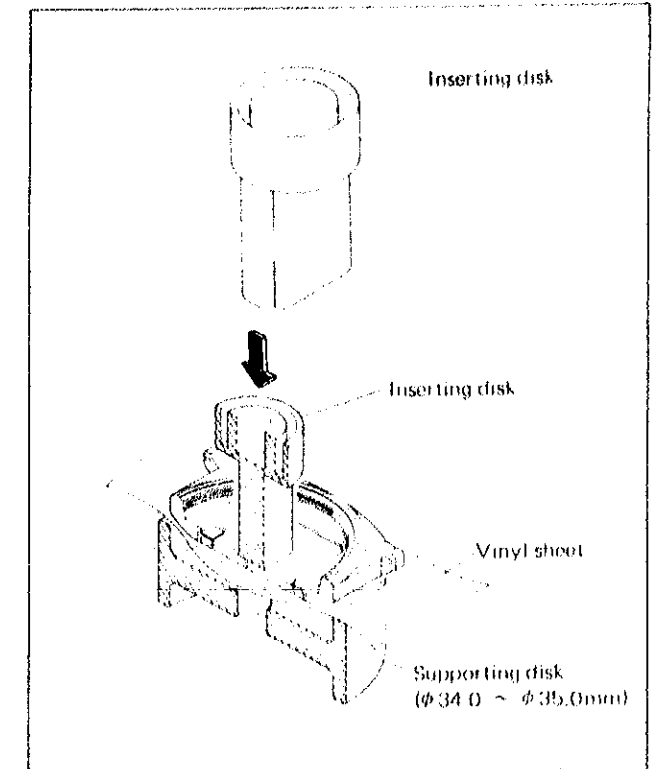

● How to reassemble the glass

- Set the plastic gasket.
 - Be sure to replace the plastic gasket with a new one.
 - Be careful not to mistake the upper side for the lower side.
- Place the glass.
 - Be careful not to mistake the upper side for the lower side. Place the round side down.
- Push in the glass.
 - Inserting disk: Plastic inserting disk
 - Supporting disk: $\phi 30.5$ or $\phi 31.0$ mm

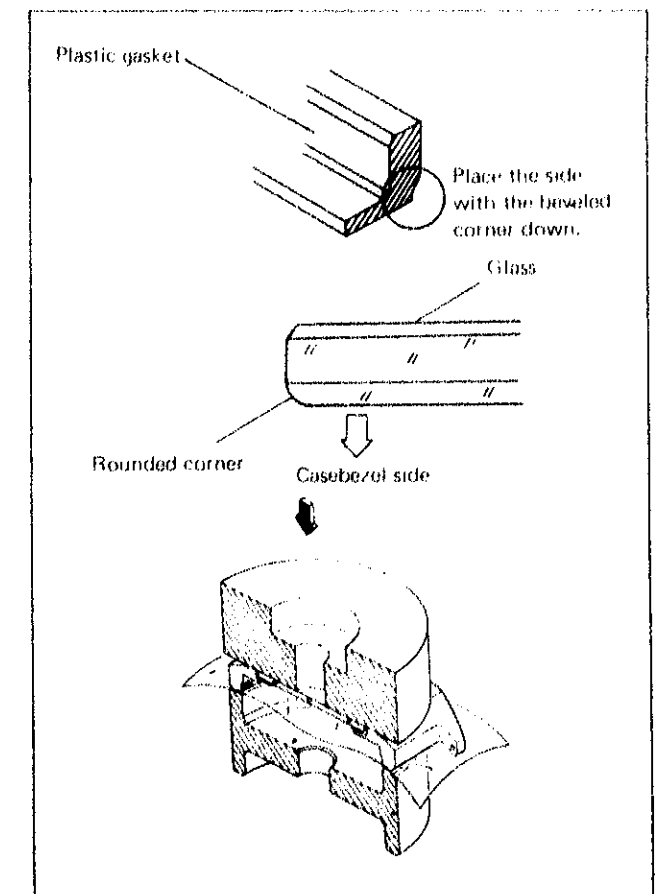

2. Disassembling and reassembling of the module

Disassembling procedures Figs.: ① ~ ⑧

Reassembling procedures Figs.: ⑧ ~ ①

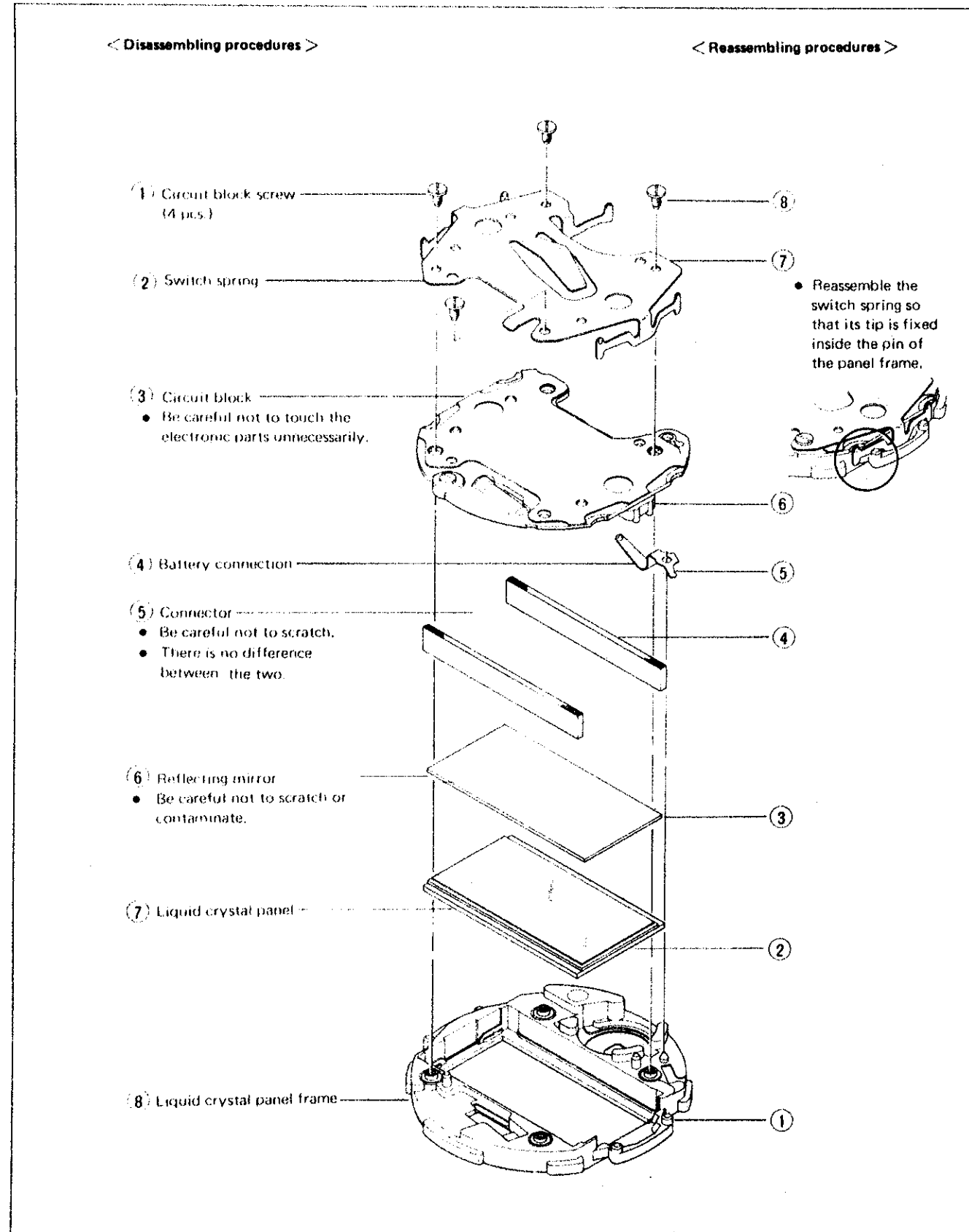

III. CHECKING AND ADJUSTMENT

Be sure to use the Static electricity protector when handling the module.

1. Guide table for checking and adjustment

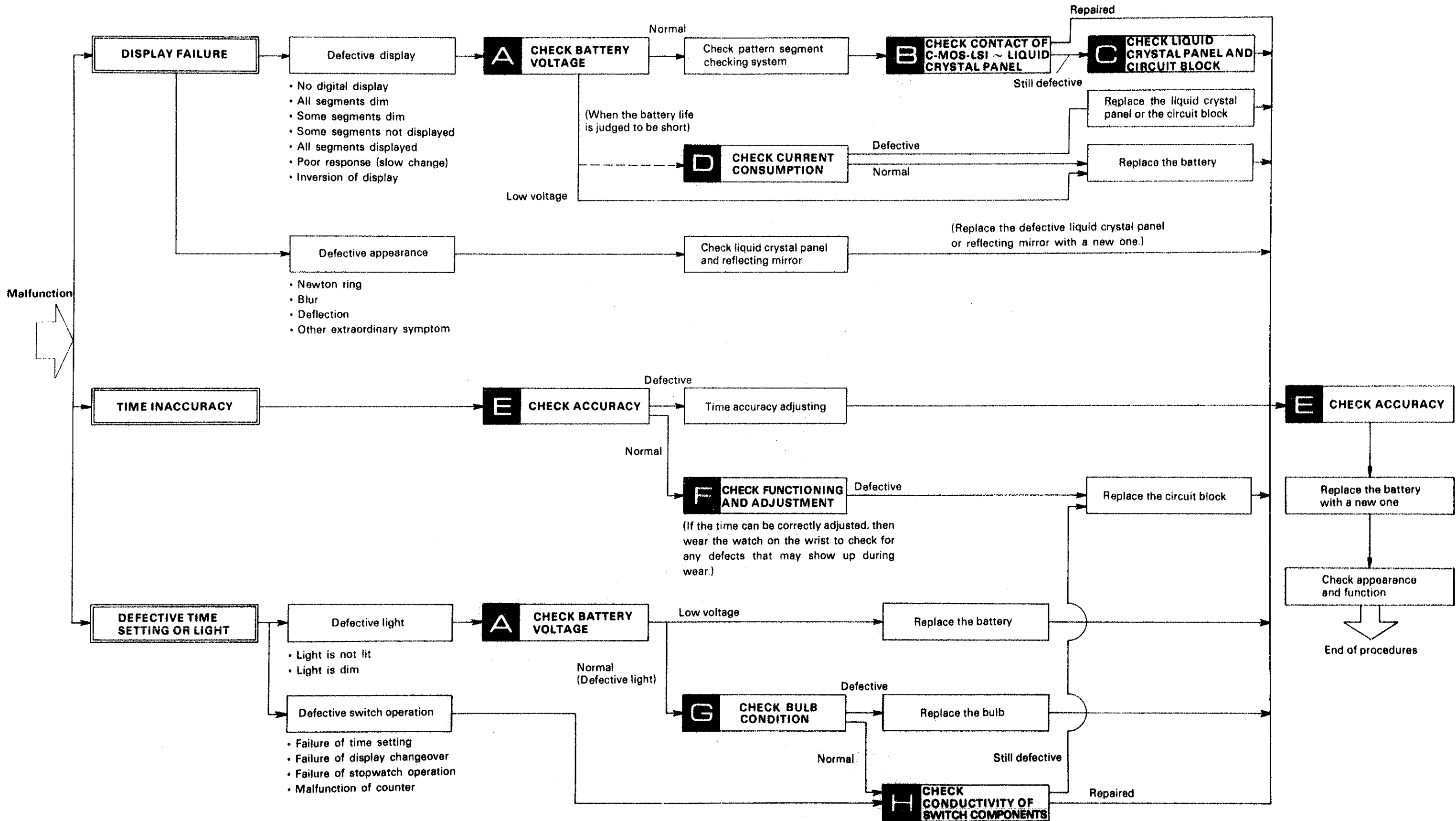

2. Relationship between the segment (Liquid Crystal Panel Electrode) and the C-MOS-LSI output terminal

A complete knowledge of how the segment (Liquid Crystal Panel Electrode) works with the C-MOS-LSI output terminal will provide the proper procedures for checking and adjustment.

● Designation of segment

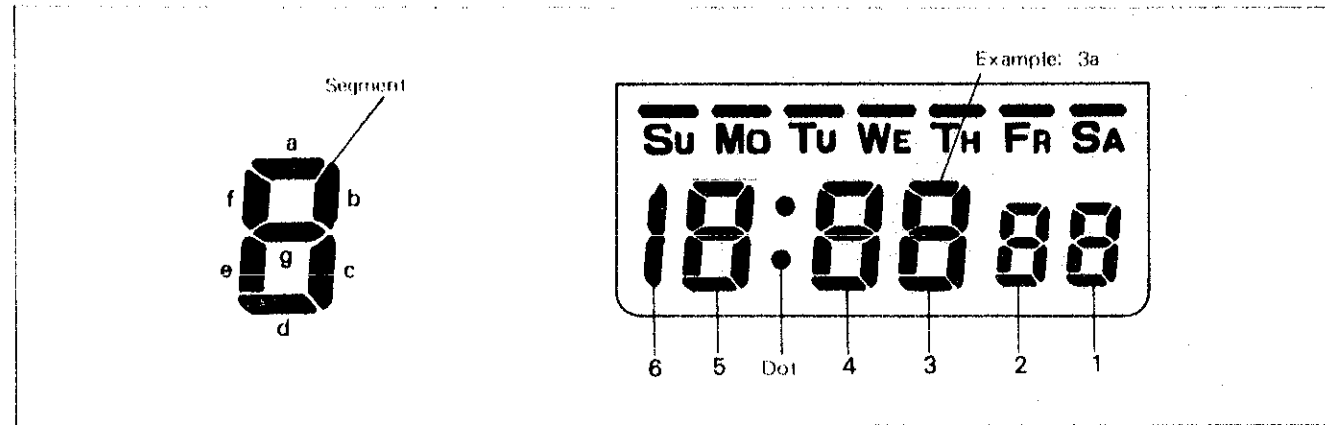

● Relationship between the segment and the C-MOS-LSI output terminal

The liquid crystal panel electrode is connected electrically with each segment which forms a digital figure as shown in the illustration of the panel pattern below.

(The panel pattern can be seen if the panel is slightly tilted and looked at in an angular position.) Also, the liquid crystal panel electrode is connected electrically with the C-MOS-LSI output terminal by the connector.

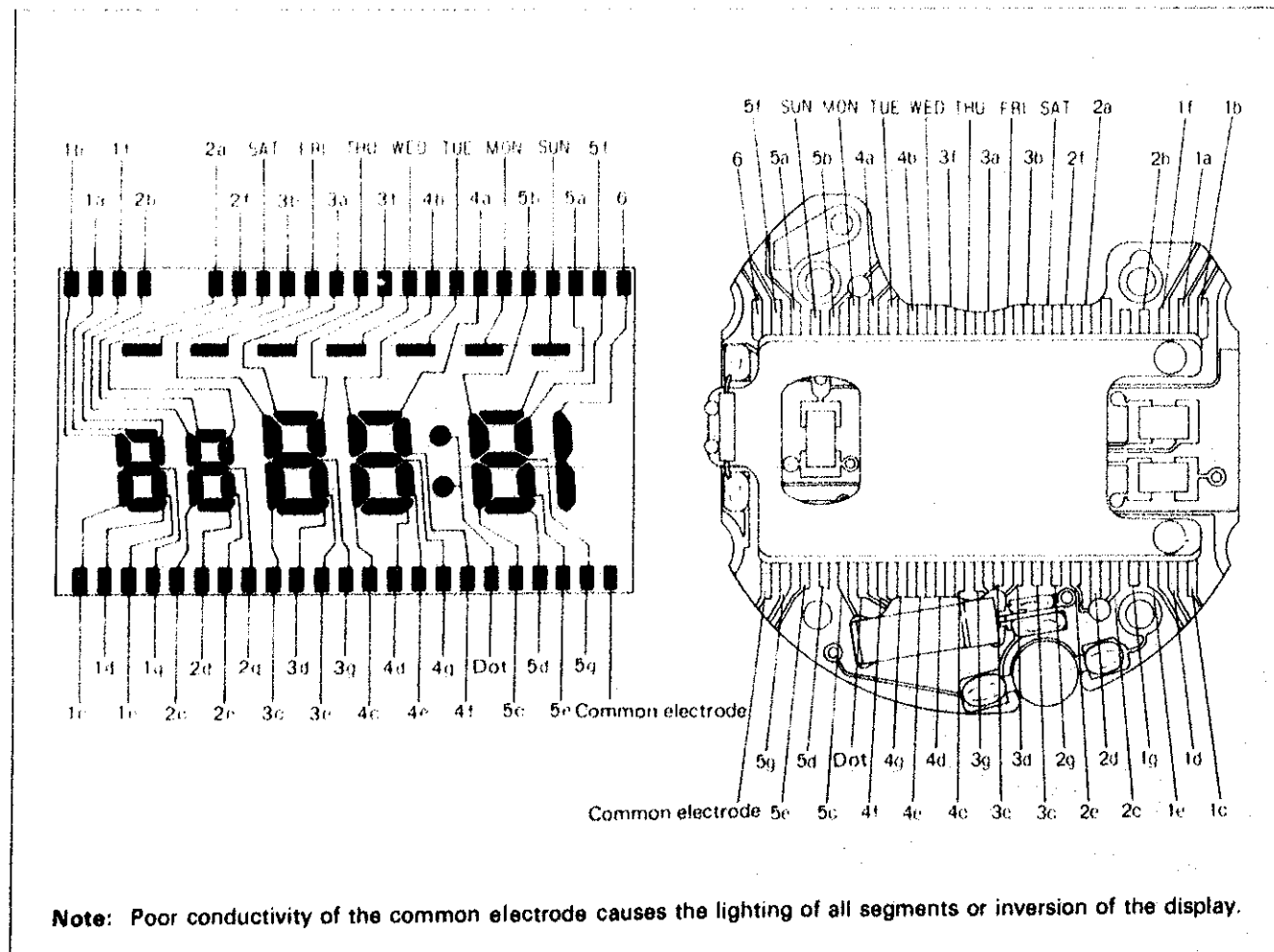



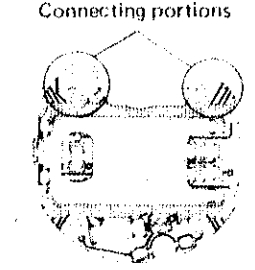

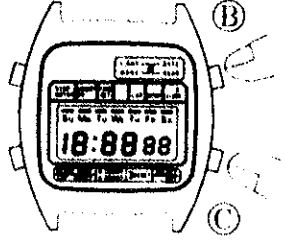
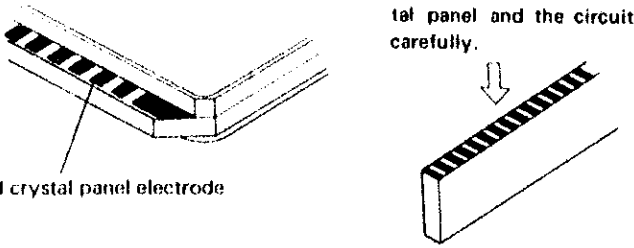
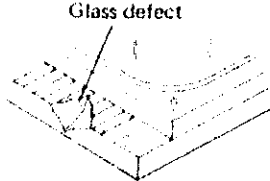
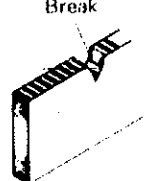
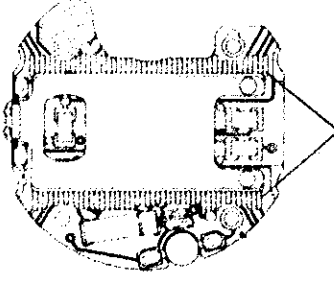

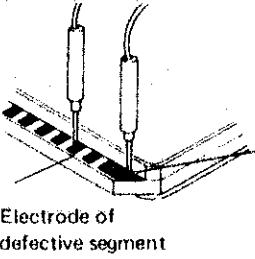
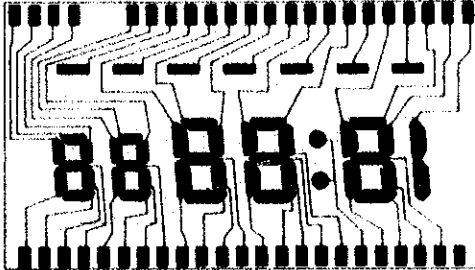
3. Procedures for checking and adjustment

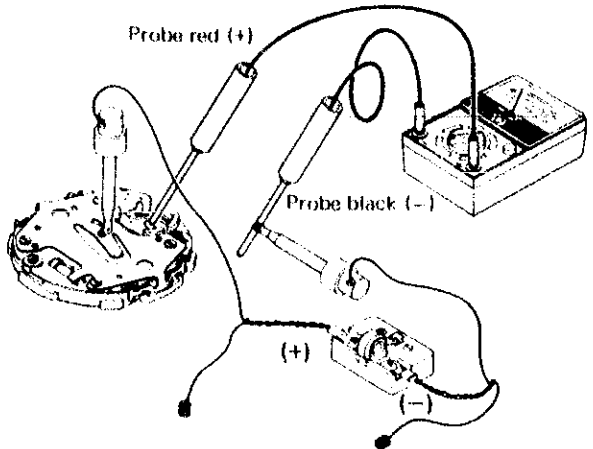
	Procedures	Result and repair
CHECK BATTERY VOLTAGE	<p>Check battery voltage.</p> <div style="border: 1px solid black; padding: 5px; margin: 10px 0;"> <p>When there is battery electrolyte leakage, refer to "HOW TO CHECK BATTERY ELECTROLYTE LEAKAGE AND REPAIR" below for repairing.</p> </div>	<p>More than 1.5V... Normal Less than 1.5V... Defective</p>
HOW TO CHECK BATTERY ELECTROLYTE LEAKAGE AND REPAIR	<ol style="list-style-type: none"> (1) Remove the module from the case. (2) Disassemble the module. (3) Wipe off battery electrolyte on the circuit block. <ol style="list-style-type: none"> 1. Wipe off battery electrolyte with a cloth moistened with distilled water. (If distilled water is not available, use tap water.) <div style="border: 1px solid black; padding: 5px; margin: 10px 0;"> <p>Note:</p> <ul style="list-style-type: none"> ● Do not expose the trimmer condenser to water or alcohol, and if it is exposed, there may be a change in the condenser capacity and eventually in the time accuracy. ● Do not use a cloth which gives off lint, such as gauze, flannel, etc. </div> <p>○ When the circuit block is cleaned, be sure to clean the connecting portions.</p> <div style="text-align: center; margin: 10px 0;">  <p>Connecting portions</p> </div> <p>If the circuit block is badly contaminated with battery electrolyte, replace the battery connection, circuit block or switch spring with a new one. (Example: When the printed circuit of circuit block is rusted.)</p> <ol style="list-style-type: none"> 2. Rinse with alcohol. (If the cleaned portions remain wet with water, they will corrode with rust.) 3. Dry with warm air by using a dryer. (4) Clean the other parts (switch spring, liquid crystal panel frame, battery connection, etc.) <ol style="list-style-type: none"> 1. Wipe off battery electrolyte on each part with a soft brush moistened with distilled water. (If distilled water is not available, use tap water.) 2. Rinse with alcohol. 3. Dry with warm air by using a dryer. (5) Reassemble the module. Replace the battery with a new one. (6) Check to see if the time and calendar function, the stopwatch function, the calendar function and the current consumption are normal. 	

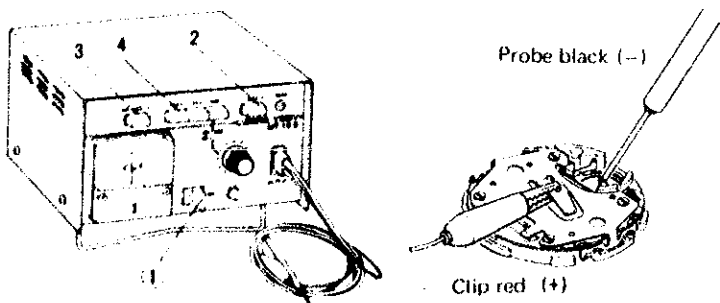
	Procedures	Result and repair
CHECK PATTERN SEGMENT CHECKING SYSTEM	<p>If some segments are dead or dim, set the mode for the time and calendar setting function. Then depress buttons B and C together to find defective segments. (If there is no defective segment all segments light up.)</p> 	<p>Proceed to 13</p>
CHECK CONTACT OF C-MOS-LSI ~ LIQUID CRYSTAL PANEL	<p>After removing the liquid crystal panel, check for poor conductivity of the liquid crystal panel, connector and C-MOS-LSI output terminal whose segments are found to be defective in "CHECK PATTERN SEGMENT CHECKING SYSTEM." (Refer to the "Relationship between the segment and the C-MOS-LSI output terminal" on page 8. Use a microscope for checking.)</p> <p>(1) Check for dust, lint and other contamination on the connector and liquid crystal panel electrode.</p> <p>Be sure to check the connecting portion of the liquid crystal panel and the circuit block carefully.</p>  <p>Liquid crystal panel electrode</p> <p>(2) Check for any scratches, cracks and breaks of the connector and the liquid crystal panel.</p>  <p>Glass defect</p>  <p>Break</p> <p>(3) Check for dust, lint and other contamination on the output terminal of the circuit block.</p>  <p>Output terminal of the circuit block.</p>	<p>Uncontaminated: Normal Proceed to 13 (2). Contaminated: Defective Wipe off any foreign matter.</p> <p>No contamination, scratches, cracks, or breaks: Normal Proceed to 13 (3). Scratched, cracked or broken: Defective Replace the connector or liquid crystal panel with a new one.</p> <p>Uncontaminated: Normal Proceed to 13. Contaminated: Defective Wipe off any foreign matter.</p>

	Procedures	Result and repair
CHECK LIQUID CRYSTAL PANEL AND CIRCUIT BLOCK	<p>Check to see if the liquid crystal panel and the circuit block function correctly. (Refer to the "Relationship between the segment and the C-MOS-LSI output terminal" on page 8.)</p> <p>(1) Check liquid crystal panel.</p> <p>1. Set up the volt-ohm-meter. Range to be used: OHMS $R \times 1 \sim R \times 1k$</p> <div style="border: 1px solid black; padding: 5px; margin: 10px 0;"> <p>Note: Any range will do if more than 3V is applied to the probes of the volt-ohm-meter. If less than 3V is applied to the probes, all segments may not be lit. Change the range to the one ($R \times 10k$) which is higher in resistance than $R \times 1k$.</p> </div> <p>2. Remove the liquid crystal panel from the module and turn it upside down.</p> <p>3. Measuring (Check to see if the corresponding segment lights up.)</p>  <p>Electrode of defective segment</p> <p>Note: Either red or black probe will do.</p> <p>Common electrode (Either red or black probe must be applied to the common electrode.)</p>  <p>Probe red (+) Probe black (-) Probe black (-) Probe red (+)</p> <p>(2) Check the circuit block output voltage.</p> <p>1. Set up the volt-ohm-meter. Range to be used: DC3V</p> <p>2. Place the module on the bench. Attach the current supplier to the circuit block. Clip (+): Connecting portion of the circuit block screw shown in the illustration. Clip (-): Connecting portion of the battery connection.</p> <p>3. Measuring</p> <p>Probe Red (+): Connecting portion of the circuit block screw of the circuit block shown in the illustration. Probe Black (-): Each portion of the output terminal of the C-MOS-LSI.</p>	<p>Lights up: Normal Proceed to 13 (2). Does not light up or more than two segments light up: Defective Replace the liquid crystal panel with a new one.</p> <p>More than 0.8V: Normal Return to 13. Less than 0.8V: Defective Replace the circuit block with a new one.</p>

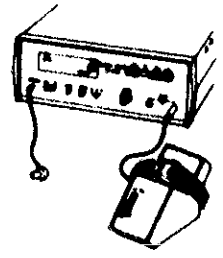
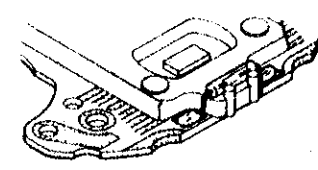
Procedures	Result and repair
<p>(1) Check to see if the current consumption is normal. (Can be checked no matter which function the watch may be performing.)</p> <ul style="list-style-type: none"> Set up the volt-ohm-meter. Range to be used: DC12μA (DC 0.03 mA)* Use the current supplier and connect as shown in the illustration below. 	<p>*Note: If the pointer of the volt-ohm-meter swings over the maximum value when DC 12μA (DC 0.03 mA) is used, change the range to a greater one where the pointer does not run over the maximum value while applying the probes to the respective portions. Then, after two or three seconds, return the range to DC 12μA (DC 0.03 mA) again for measuring.</p> <p>Less than 2.5 μA: Normal Replace the battery with a new one. More than 2.5 μA: Defective Proceed to  (2).</p>
<ul style="list-style-type: none"> Set up the Micro Test* <ol style="list-style-type: none"> Power switch... ON Polarity changeover button: + Current consumption/Voltage indication button: μA Voltage selection button: 1.55V Prove Black (-): Battery connection Clip Red (+): Switch spring 	<p>*Note: If the pointer of the Micro Test swings over the maximum value while the current consumption is measured, depress the Current consumption/Voltage indication button  so that it is released to indicate the voltage (μV) while the black probe and the red clip are applied. Then, after two or three seconds, depress the Current consumption/Voltage indication button again so that it holds in the pushed in position (μA \rightarrow) to indicate the current consumption for measuring.</p>

	Procedures	Result and repair
CHECK CURRENT CONSUMPTION	<p>(2) Disassemble the liquid crystal panel, and check to see if the current consumption is normal.</p> <p>Follow the procedures in  (1).</p>	<p>Normal: Replace the liquid crystal panel with a new one. Defective: Replace the circuit block with a new one.</p>
CHECK ACCURACY	<p>Check gain and loss of time.</p> <ol style="list-style-type: none"> Set up the Quartz Tester. Measuring 	<p>Does not lose or gain: Normal Proceed to the following procedure. Loses or gains: Defective Proceed to <u>Time accuracy adjusting.</u> Time accuracy is adjusted by turning the trimmer condenser.</p>
CHECK FUNCTIONING AND ADJUSTMENT	<p>Check to see if the watch functions correctly and can be adjusted by the button operation.</p> <ol style="list-style-type: none"> Check the stopwatch function. <ul style="list-style-type: none"> Check to see if "start", "stop", "lap release" and "reset" function correctly. Check the counter function. <ul style="list-style-type: none"> Check to see if seconds can be counted correctly or can be reset to "00" second. Check the time and calendar setting function. <ul style="list-style-type: none"> Rotate the time and calendar digits more than one cycle for each unit and check to see if each digit is advancing correctly. 	<p>Functions correctly and can be adjusted: Normal Wear the watch on the wrist to check time accuracy. Does not function correctly or cannot be adjusted: Defective Proceed to <u>Replace the circuit block.</u></p>
CHECK BULB CONDITION	<p>(1) Check to see if the bulb lead terminals touch the lead terminal of the circuit block.</p> 	<p>No exfoliation of solder: Normal Proceed to  (2). Exfoliation of solder: Defective Re-solder the foot of the bulb.</p> <p>Refer to "HOW TO REPLACE THE BULB" on page 15 for re-soldering.</p>

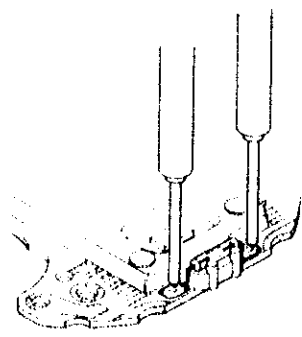
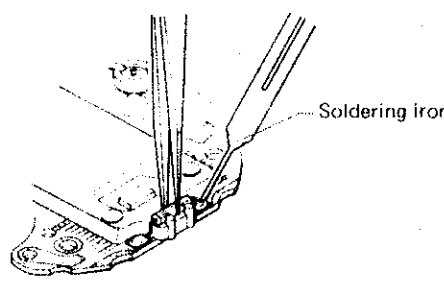
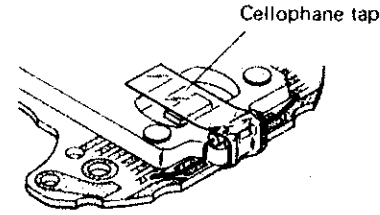
	Procedures	Result and repair
CHECK BULB CONDITION	<p>(2) Check to see if there is a broken filament in the bulb.</p> <ol style="list-style-type: none"> Set up the volt-ohm-meter. Range to be used: OHMS R × 1 Measuring Apply the two probes of the volt-ohm-meter to the bulb lead terminal as shown in the illustration.  <p><i>Note:</i> Either red or black probe will do.</p>	<p>Lights up: Normal Proceed to ■ .</p> <p>Does not light up: Defective Replace the bulb with a new one.</p> <p>Refer to "HOW TO REPLACE THE BULB" for replacing the bulb with a new one.</p>
	<p>Use the soldering iron with a thin and sharp tip, which has small heat capacity. Thickness of tip: Approx. $\phi 1.0$ mm Heat capacity: Power consumption 5W ~ 20W</p>	
HOW TO REPLACE THE BULB	<ol style="list-style-type: none"> Remove the defective bulb. Hold the defective bulb by tweezers and pull it up slightly. Then put the tip of the soldering iron on the bulb terminal and remove the bulb. Check to see if the new bulb is normal. Follow the procedures Check bulb condition for checking. Solder the feet of the bulb on the pin side of the circuit board. Be careful not to make the feet slack when soldering. Fix the bulb on the pin side of the circuit board by cellophane tape and it makes it easier to solder the bulb. As the foot of the bulb is long, cut it by nippers after it is soldered. 	 <p>Soldering iron</p>  <p>Cellophane tape</p>

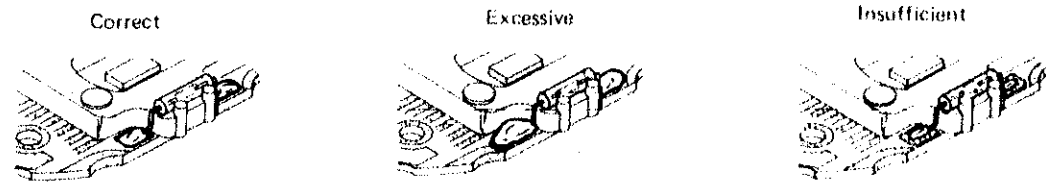
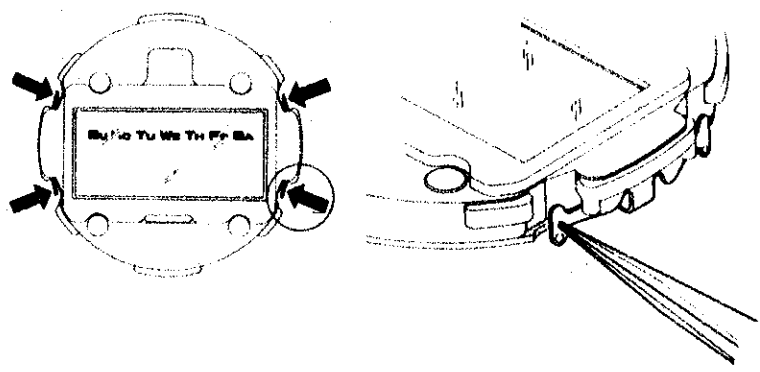
	Procedures	Result and repair
HOW TO REPLACE THE BULB	<p>Remarks:</p> <ol style="list-style-type: none"> Be careful not to hold the tip of the soldering iron on for a long time or the circuit block may be damaged. Take off the soldering iron from the connecting portion when solder becomes evenly spread on the circuit board. (Approx. 1 second.) Be careful not to touch the reflecting mirror spacer (made of plastic) with the soldering iron.  <p>Correct Excessive Insufficient</p> <p>(5) Check the bulb condition again.</p>	
CHECK CONDUCTIVITY OF SWITCH COMPONENTS	<p>Check to see if the switch spring functions correctly.</p> <ol style="list-style-type: none"> Check to see if the switch springs (four arrow-marked portions shown in the illustration below) function correctly when they are pushed in. <ol style="list-style-type: none"> Check to see if the four arrow-marked springs touch the switch terminals of the circuit block when they are pushed in with the tips of tweezers and that they do not touch the switch terminals of the circuit block when released. Check for dust, lint and other contamination on the contacting portions. 	<p>Functions correctly: Normal Does not function correctly: Defective</p> <p>If the switch springs do not function correctly after they are adjusted, replace them with new ones.</p> <p>No dust, lint or uncontaminated: Normal Proceed to ■ (2). Dust, lint or contaminated: Defective Wipe off any foreign matter.</p>

All procedures of Disassembling, Reassembling, Checking and Adjustment are completed.

IV. PARTS LIST OF MODULE

Cal. Y729A

PART NO.	PART NAME	PART NO.	PART NAME
4001 801	Circuit block		
4246 801	Switch spring		
4270 800	Battery connection		
4313 800	Connector		
4398 800	Liquid crystal panel frame		
4510 810	Liquid crystal panel		
4521 710	Reflecting mirror (Silver)		
4521 711	Reflecting mirror (Gold)		
4530 849	Bulb		
022 283	Circuit block screw		
☆ SONY EVEREADY 392	Silver oxide battery		
☆ U.C.C. 392			
☆ Maxell SR41W			

Remarks:

Battery

- ☆ SONY EVEREADY 392
- ☆ U.C.C. 392
- ☆ Maxell SR41W

Additional batteries for this calibre might be added as substitutes in the future.

☆ Please see remarks.