

SEIKO

DIGITAL QUARTZ

Cal. S1 Series

**(S101A
S111A
S119A
SP11)**

**PARTS
CATALOGUE**

Cal. S1 Series (S101A, S111A, S119A)

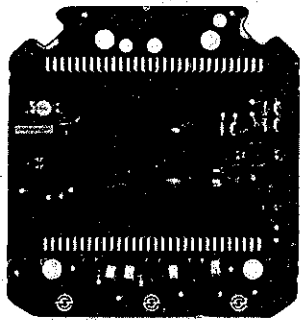
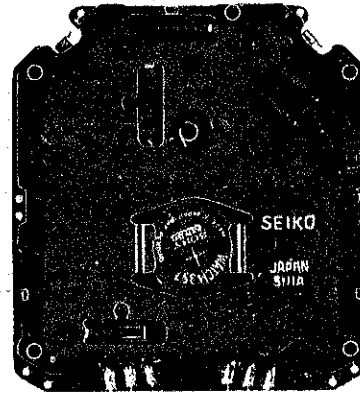
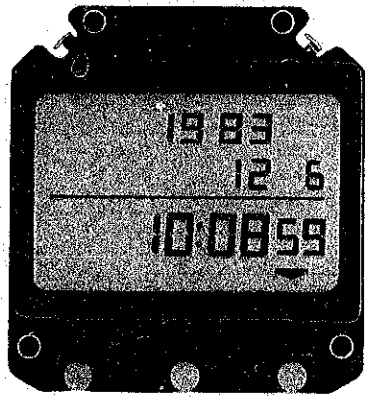

4001 825



4225 820



4246 825



4246 826



4270 825



4293 825



4313 825



4313 826

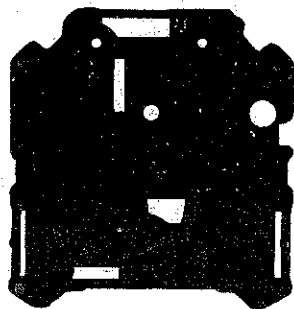

4410 825



4450 825

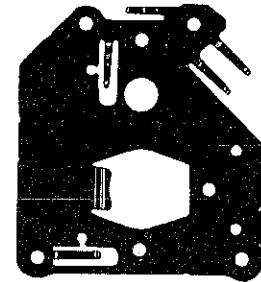

4457825

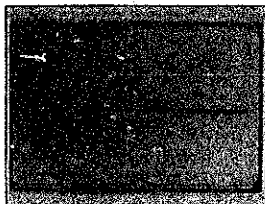

4510 852

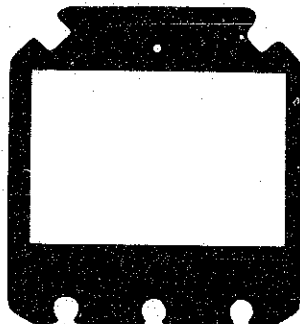

4512 825

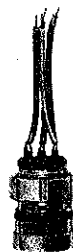

7504 505



7504 509



☆ SONY EVEREADY 357



022 904



022 905

2/1

87.5%

Cal. S1 Series (S101A, S111A, S119A)

Characteristics

	Cal.	S101A	S111A	S119A
Casing diameter		46.7 × 43.0 mm		
Maximum height		10.2 mm without battery		
Frequency of quartz crystal oscillator		32,768 Hz (Hz=Hertz Cycles per second)		
Regulation system		Trimmer condenser		
Additional mechanism		Time and calendar function		
		Stopwatch function		
		Memory function		
		—	Print out function	

PART NO.	PART NAME	PART NO.	PART NAME
4001 825	Circuit block (Cal. S111)		
4001 826	Circuit block (Cal. S101)		
4001 827	Circuit block (Cal. S119)		
4225 820	Battery clamp (Cal. S111)		
4225 822	Battery clamp (Cal. S101)		
4225 824	Battery clamp (Cal. S119)		
4246 825	Buzzer lead terminal		
4246 826	Terminal for reset connection		
4270 825	Battery connection (—)		
4293 825	Switch lever support		
4313 825	Connector		
4313 826	Switch connector		
4410 825	Circuit cover		
4450 825	Switch lever		
4457 825	Circuit block cover		
4510 852	Liquid crystal panel (Cal. S111)		
4510 853	Liquid crystal panel (Cal. S101)		
4510 854	Liquid crystal panel (Cal. S119)		
4512 825	Liquid crystal panel frame		
7504 505	Plug for stopwatch (Cal. S111, S119)		
7504 509	Plug cap (Cal. S111, S119)		
022 904	Circuit block cover screw		
022 905	Battery clamp screw		
☆SONY EVEREADY 357 ☆U.C.C. 357	Silver oxide battery		

Remarks :

Battery

☆SONY EVEREADY 357 } The substitutive battery might be added to the applied battery in the future.
 ☆U.C.C. 357 } In that case, please refer to "BATTERY LIST FOR SEIKO QUARTZ WATCHES".

TECHNICAL GUIDE

SEIKO DIGITAL QUARTZ

CAL. S101A
CAL. S111A
CAL. S119A

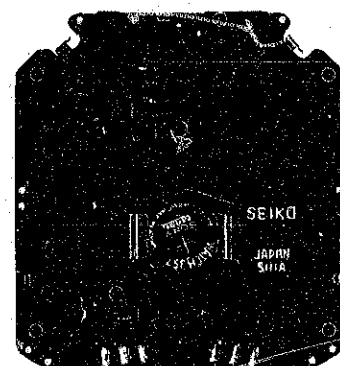
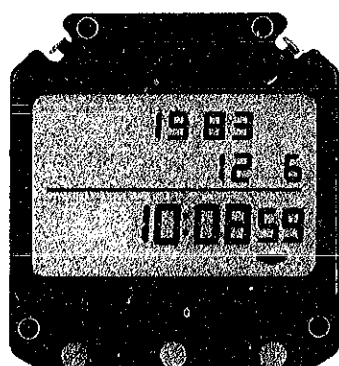

CONTENTS

STOPWATCH

I. SPECIFICATIONS	1
II. STRUCTURE OF THE CIRCUIT BLOCK	1
III. DESIGNATION AND OPERATION	2
IV. DISASSEMBLING, REASSEMBLING, AND LUBRICATING OF THE CASE	3
1. Cals. S111A and S119A	3
2. Cal. S101A	4
V. DISASSEMBLING, REASSEMBLING, AND LUBRICATING OF THE MODULE	5
VI. RELATIONSHIP BETWEEN THE SEGMENT (LIQUID CRYSTAL PANEL ELECTRODE) AND THE C-MOS-LSI OUTPUT TERMINAL	6
VII. CHECKING AND ADJUSTMENT	7
• Check battery voltage	7
• Check current consumption	8
• Check liquid crystal panel and circuit block	9
• Check functioning and adjustment	9
• Check water resistance	10
• Check all the segments lit up	10

PRINTER

VIII. SPECIFICATIONS	11
IX. STRUCTURE OF THE CIRCUIT BLOCK	11
X. LIST OF THE SCREWS USED	12
XI. DISASSEMBLING AND REASSEMBLING OF THE SYSTEM PRINTER SP11	12
1. Roll paper setting block	12
2. Battery hatch ~ Holder	13
3. Printer unit ~ Front cover	14
XII. CORD	15

I. SPECIFICATIONS

Item	Cal. No.	S111A	S119A	S101A
Display medium		Nematic Liquid Crystal, FEM (Field Effect Mode)		
Liquid crystal driving system		Multiplex driving system		
Display system				
Time and calendar function		24-hour indication		
Memory function		8 measurement data		6 measurement data
Frequency measuring function			—	10 strokes/min. ~ 180 strokes/min.
Stopwatch function		Hours, minutes, seconds, and 1/100 second up to 10 hours.	Decimal notation Up to 100,000 DM in 0.1 DM	Hours, minutes, seconds, and 1/100 second up to 10 hours.
Additional mechanism		<ul style="list-style-type: none"> • Automatic calendar display system (1980 - 2019) • Time and calendar setting function • All segment light up system • Automatic return system 		
		Memory overflow alarm sound (Only when the watch is connected to the system printer SP11.)		—
Loss/gain		Monthly rate at normal temperature range: less than 15 seconds		
Module size	Outside diameter	46.7 mm between 6 o'clock and 12 o'clock sides 43.0 mm between 3 o'clock and 9 o'clock sides		
	Height	10.2 mm		
Regulation system		Trimmer condenser		
Measuring gate by quartz tester		Any gate can be used.		
Battery		Maxell SR44W, U.C.C. 357, SONY EVEREADY 357 Battery life is approximately 3 years. Voltage: 1.55V		
Printer to be connected		SP11 - Connectable		—

II. STRUCTURE OF THE CIRCUIT BLOCK

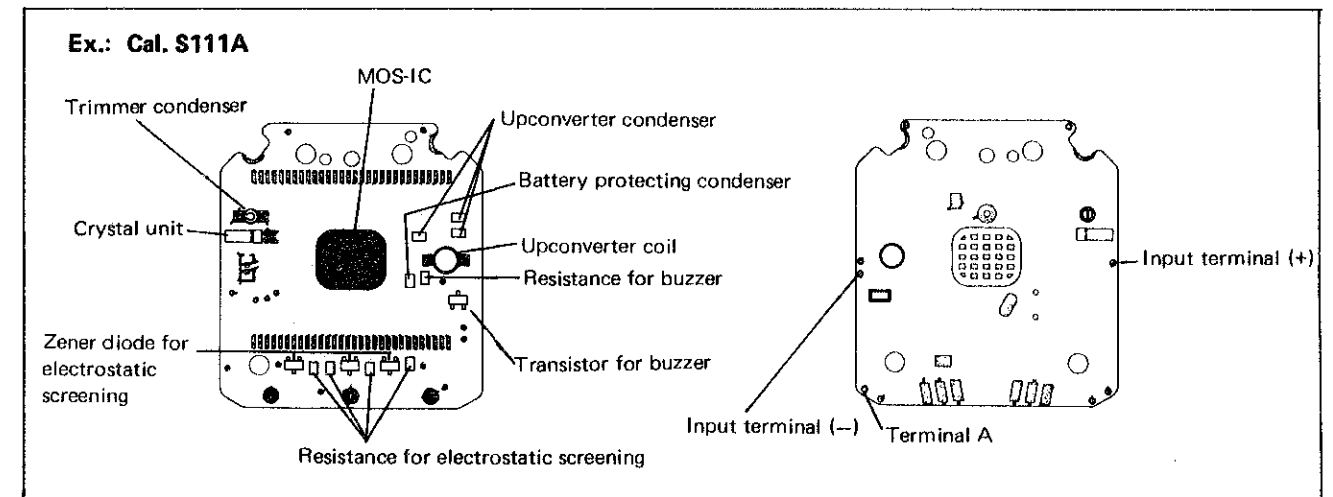

Note: The resistance for electrostatic screening and the Zener diode for electrostatic screening are not provided in Cal. S101A.

III. DESIGNATION AND OPERATION

[Cal. S111A, S119A]

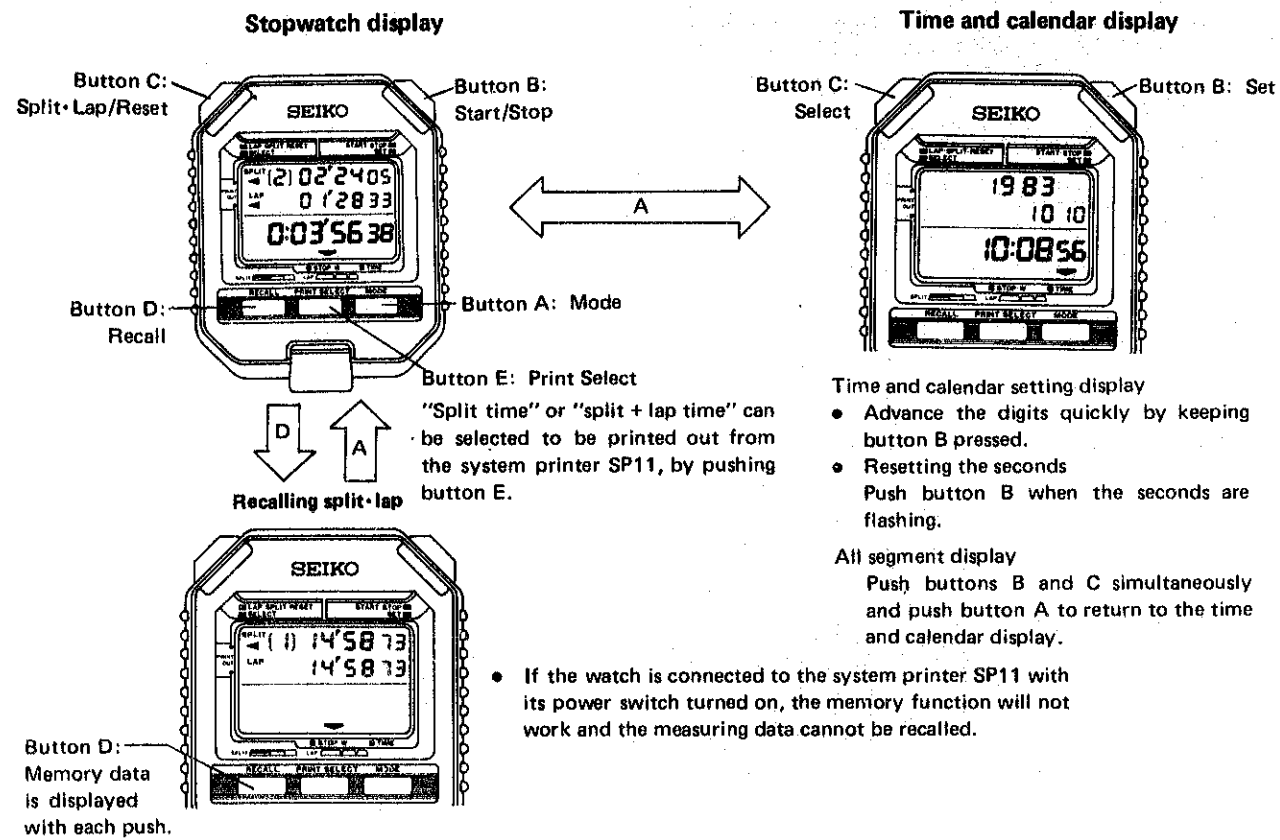

[Cal. S101A]

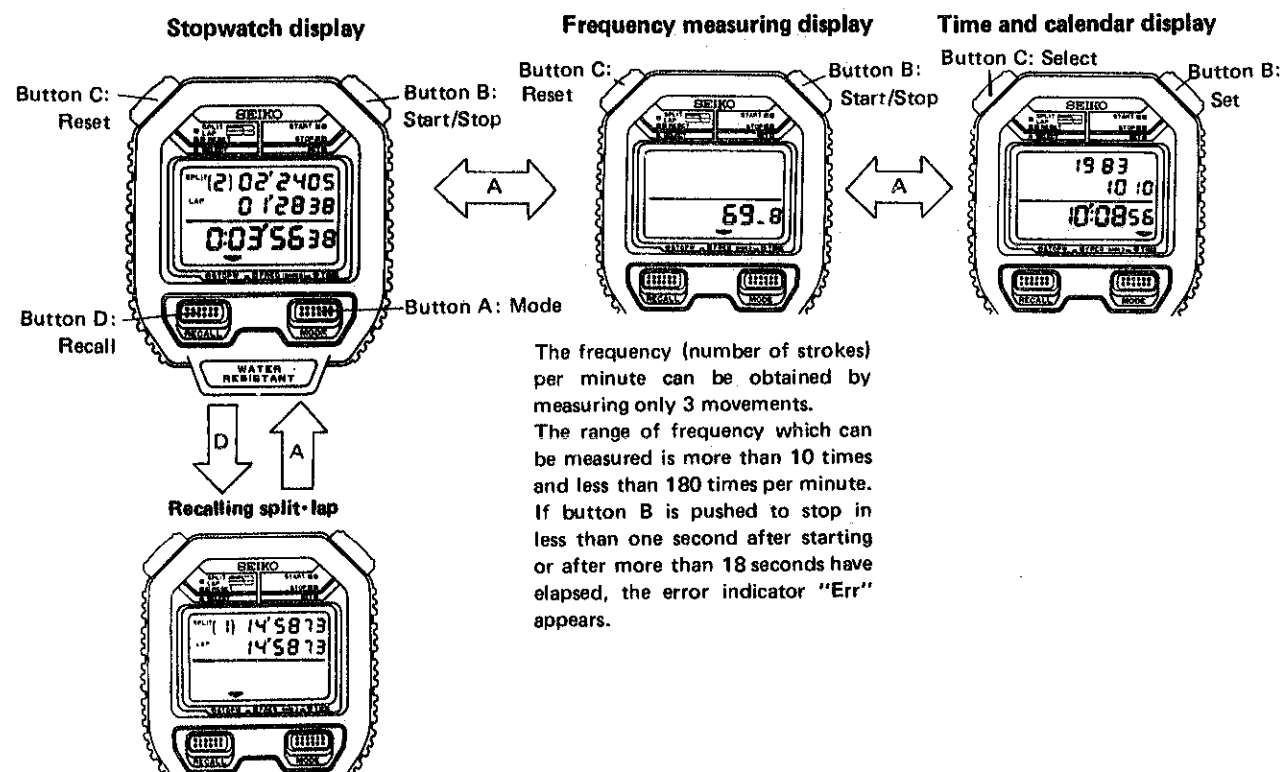

IV. DISASSEMBLING, REASSEMBLING, AND LUBRICATING OF THE CASE

1. Cals. S111A and S119A

Disassembling procedures Figs.: ① → ⑤
Reassembling procedures Figs.: ⑤ → ①

Lubricating: ● Silicone grease 500,000 c.s. Normal quantity

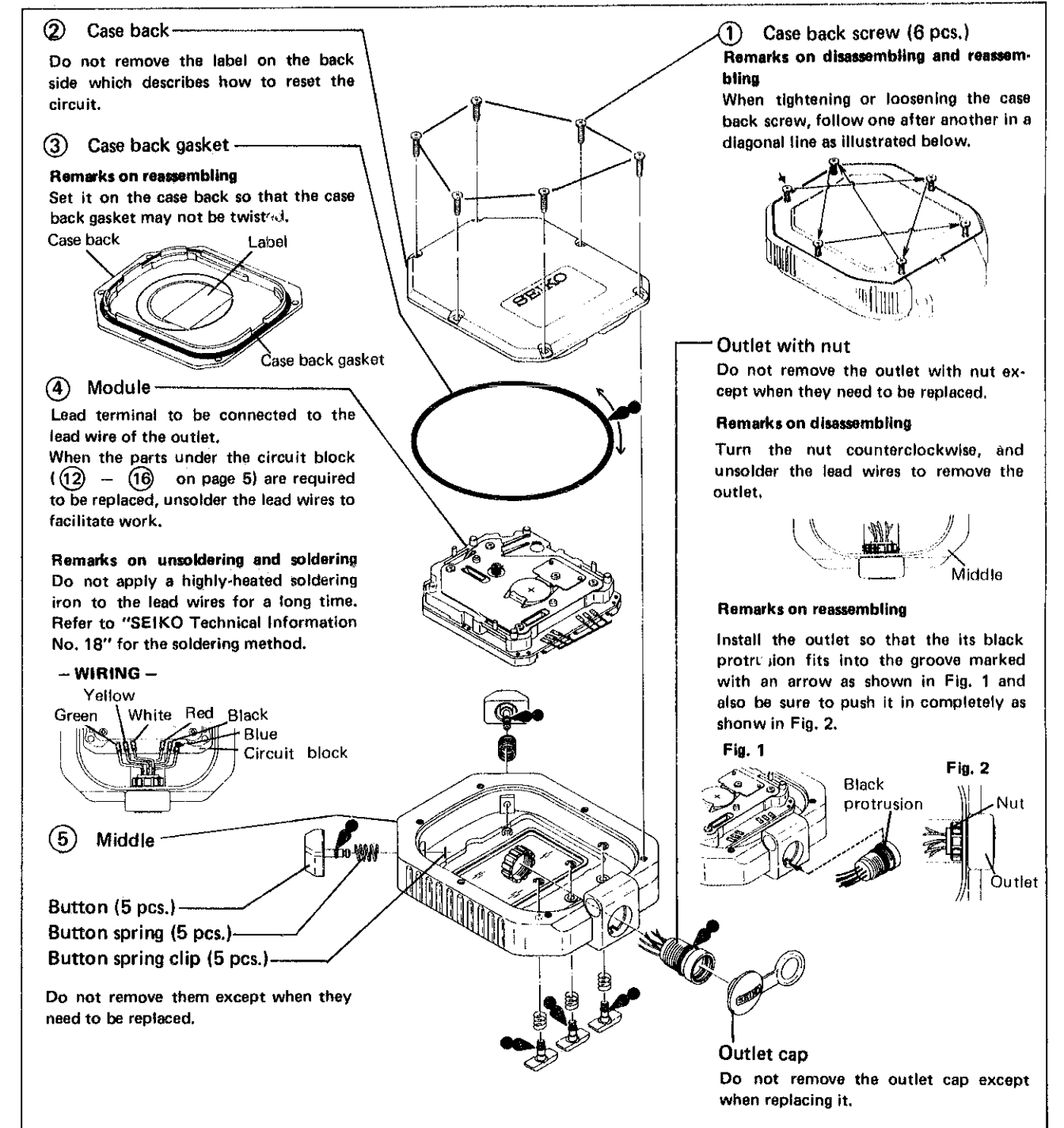

2. Cal. S101A

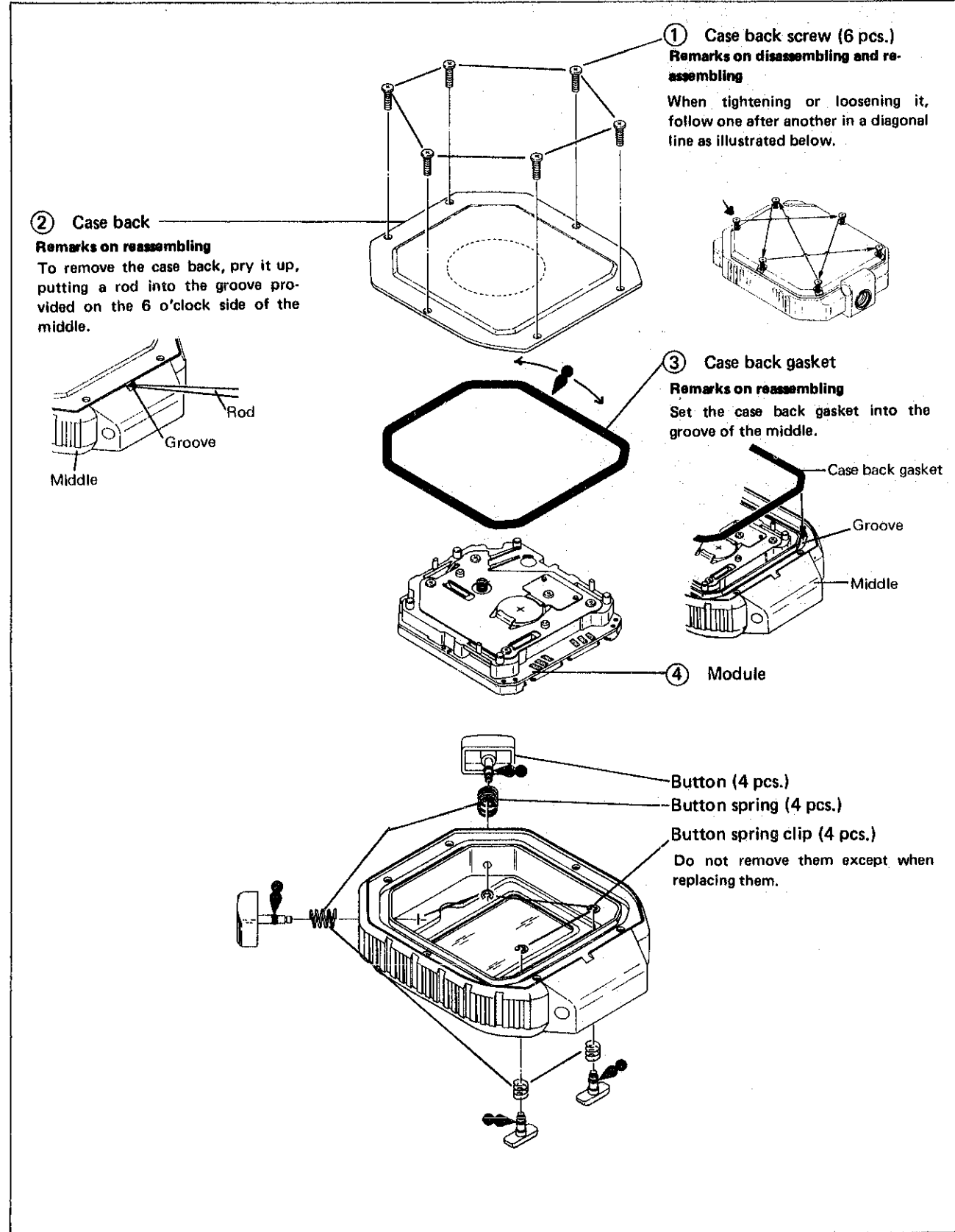

Disassembling procedures Figs.: ① → ④
 Reassembling procedures Figs.: ④ → ①

Lubricating: ● Silicone grease 500,000 c.s.
 Normal quantity

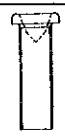

V. DISASSEMBLING, REASSEMBLING, AND LUBRICATING OF THE MODULE

• List of the screws used

Shape	Part No.	Name	Shape	Part No.	Name
	022 904	Circuit block cover screw (4 pcs.)		022 905	Battery clamp screw (1 pc.)

Disassembling procedures Figs.: ① → ⑯
 Reassembling procedres Figs.: ⑯ → ①

Lubricating: ● SEIKO Watch Oil S-6
 Normal quantity

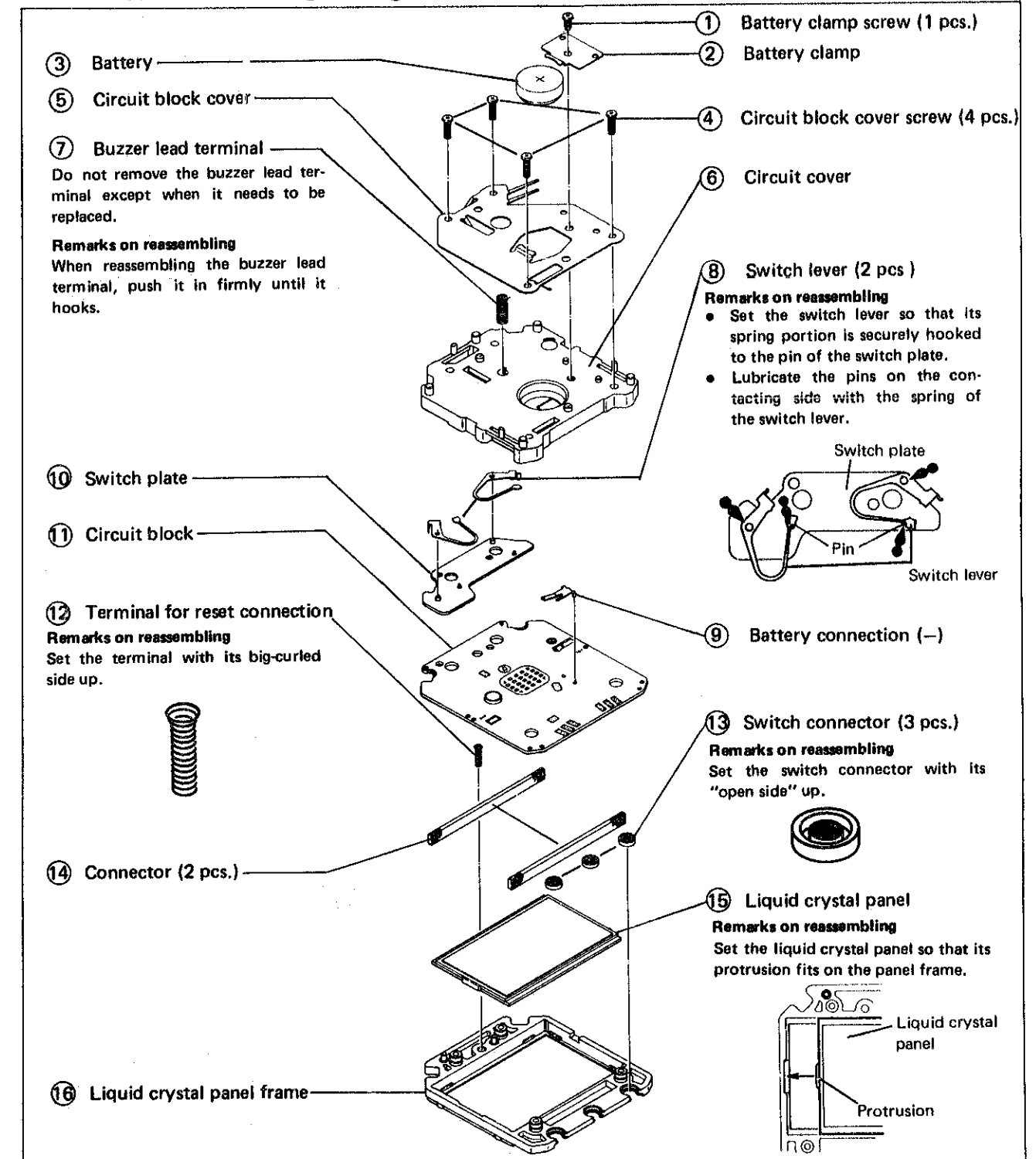

VI. RELATIONSHIP BETWEEN THE SEGMENT (LIQUID CRYSTAL PANEL ELECTRODE) AND THE C-MOS-LSI OUTPUT TERMINAL

• Designation of the segment

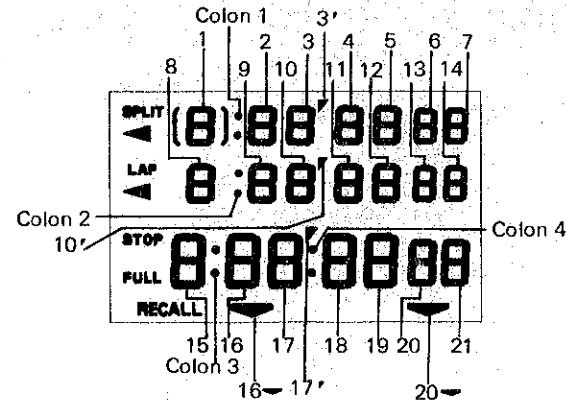
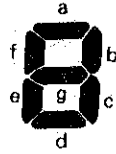

• Relationship between the segment and the C-MOS-LSI output terminal

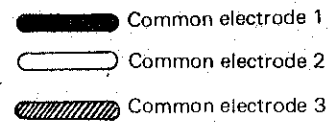
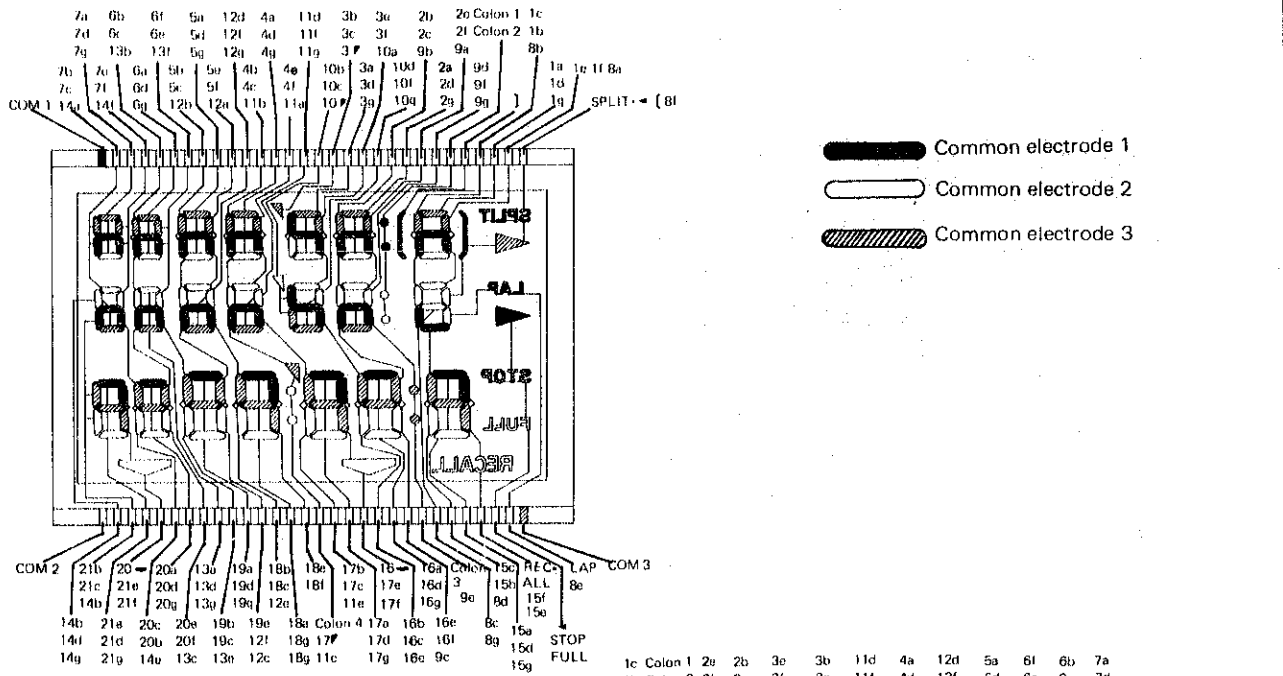

How to identify the circuit blocks for Cal. S101A, S111A, and S119A

Cal. 101A

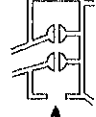

Cut

Cal. S119A

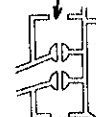

Cut

Cal. S111A

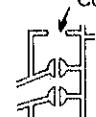

Cut

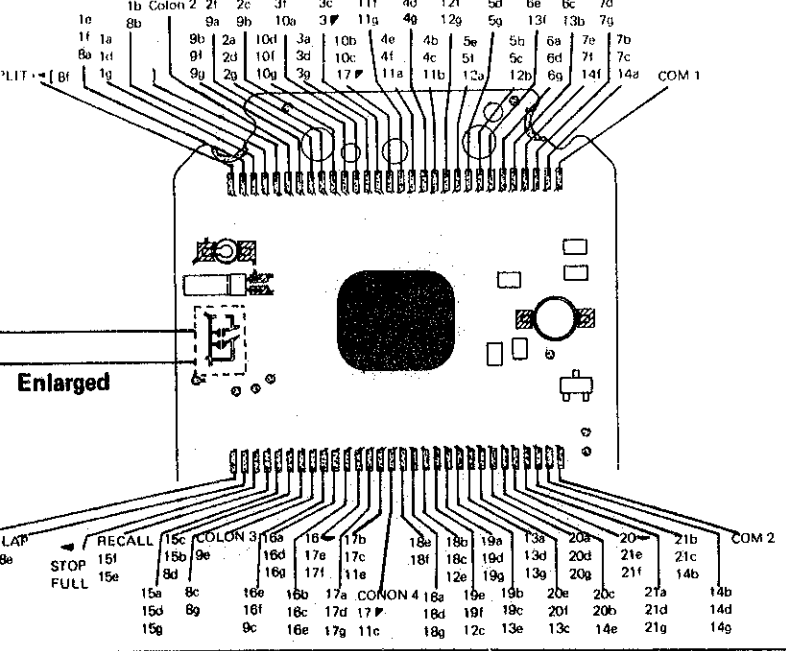

VII. CHECKING AND ADJUSTMENT

- The explanation here is only for the particular points of Cals. S101A, S111A, and S119A. Refer to the "TECHNICAL GUIDE, GENERAL INSTRUCTION" for SEIKO Digital Quartz for details.

Procedure

Remarks on replacing the battery

When installing the battery, be sure to reset the circuit to display as shown in the illustration by conducting either way as follows:

— Watch complete —

Push all the buttons at the same time continuously for 2 to 3 seconds.

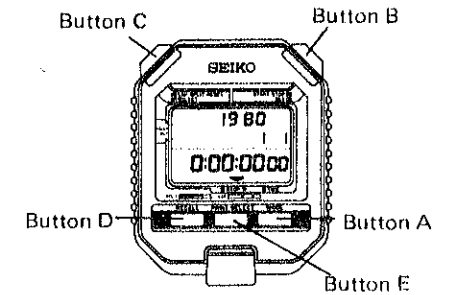

— Module —

Apply the tips of tweezers as shown in the illustration.

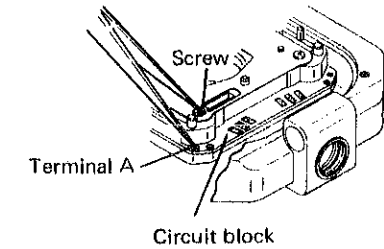

CHECK BATTERY VOLTAGE

Use the Digital Multi Tester S 841.

Range to be used: DCV

Result:

Normal: More than 1.55V

Defective: Less than 1.55V

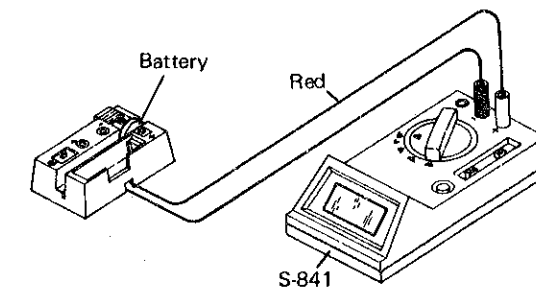

Procedure

CHECK CURRENT CONSUMPTION

1. Current consumption for the whole of the module

Range to be used: DC μ A

(S-841: DC μ mA)

After setting as shown in Fig. 1, reset the circuit as shown in Fig. 2.

Fig. 1

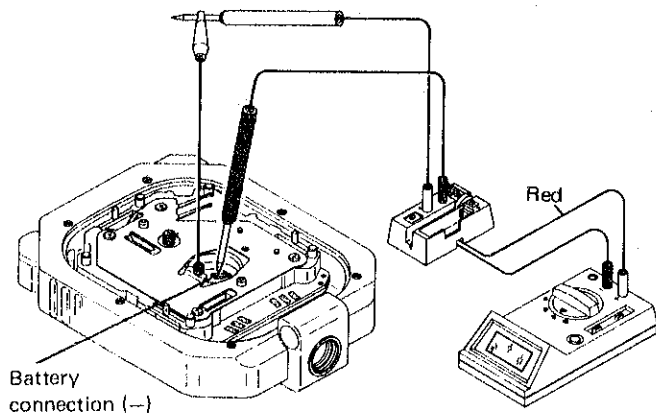
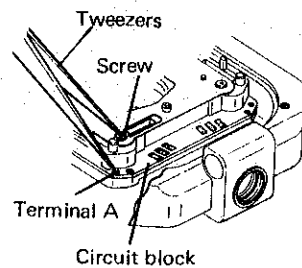

Fig. 2



Result:

Normal: Less than 6.2 μ A
Defective: More than 6.2 μ A

2. Current consumption for the circuit block alone

After setting as shown in Fig. 1, reset the circuit as shown in Fig. 2.

Fig. 1

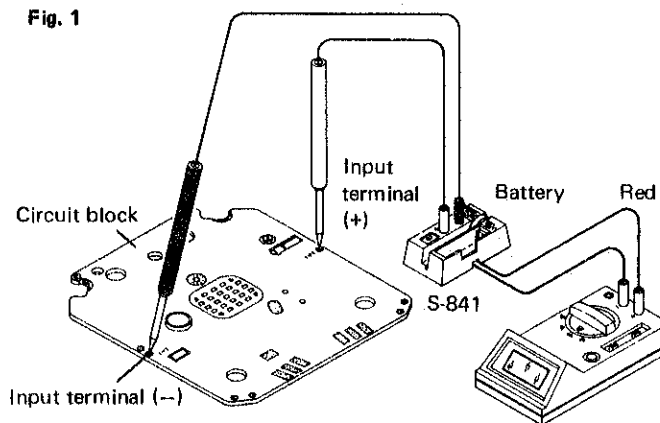
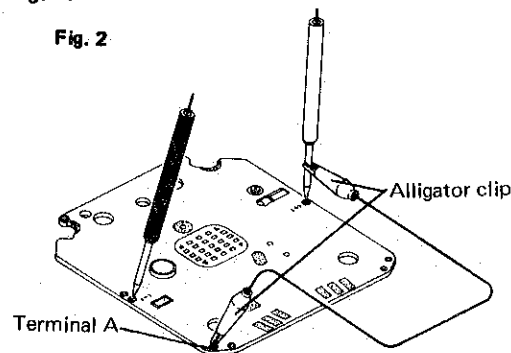

Fig. 2



Result:

Normal: Less than 5.0 μ A
Defective: More than 5.0 μ A

CHECK LIQUID CRYSTAL PANEL AND CIRCUIT BLOCK

Range to be used: DCV (S-841: DC V)

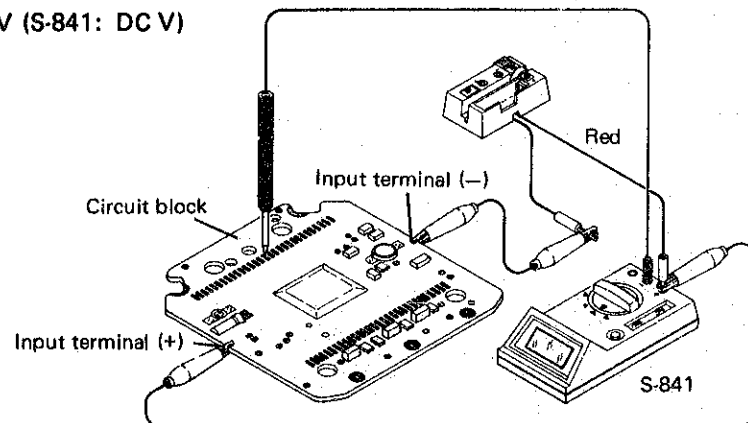

Procedure

CHECK FUNCTIONING AND ADJUSTMENT

Cal. S111A and S119A

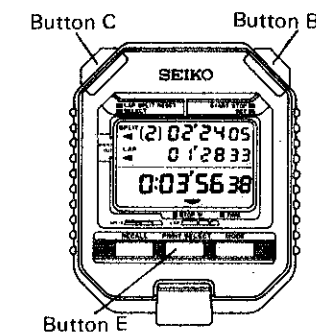

1. Check the memory function.

- ① Push button B (start) in the stopwatch function.
- ② Push button C (split-lap) 8 times in case of Cals. S111A and S119A and 6 times in case of Cal. 101A, and then push button B (stop).
- ③ Push button E (recall) to see whether the memory data can be recalled up to as many as 8 times in case of Cals. S111A and S119A and 6 times in case of Cal. S101A.

Note:

If the stopwatch is connected to the system printer SP11 with its power switch turned on, the memory function will not work. Be sure to disconnect the printer or turn off its power switch.

Result:

Normal: The memory can be recalled.

Defective: The memory cannot be recalled.

Reset the circuit by pushing all buttons simultaneously and check the memory function.

In case the memory function does not still work correctly, replace the circuit block with a new one.

2. Check the system printer functioning.

(In case the system printer SP11 is used with Cals. S111A and S119A)

If the system printer does not function normally, go through the following procedures.

Fig. 1

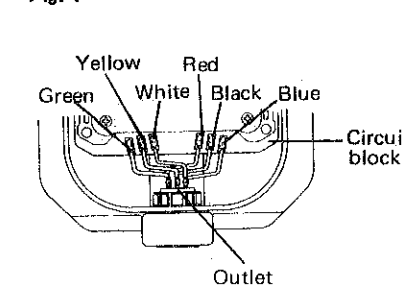

a) Watch module

- Check to see that the six lead wires are correctly soldered to the lead terminal of the circuit block in the right order as shown in Fig. 1.
- Check to see that the lead wires to be connected with the outlet are properly soldered (Fig. 1).
- Check to see that the adjoining soldered parts touch to cause a short circuit (Fig. 2).

Result:

Each lead wire is correctly soldered.

Proceed to procedure b).

A lead wire is not soldered correctly.

Solder it again.

b) System printer (SP11)

Check the system printer's battery voltage.

Fig. 2

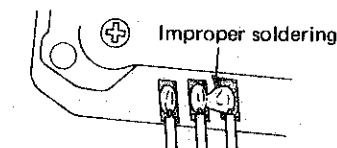

Result:

Normal: More than 1.55V for each piece

Defective: Less than 1.55V for each piece.

Replace the batteries with new ones.

Procedure

Cal. S101A

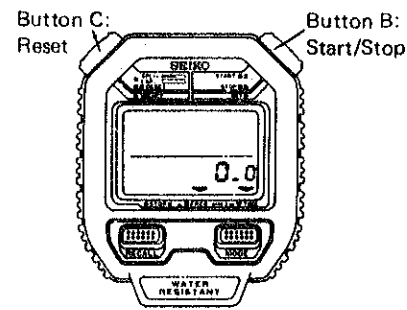

Check to see if the frequency measuring function is correctly activated.

- ① Push button B to see if the start and stop are correctly made.
- ② Check to see if "180.0" flashes for approximately 1 second just after button B is pressed to start measuring, and if "Err" is shown by pressing button B while "180.0" is still flashing.
- ③ Check to see if "Err" is shown after a lapse of 10.0 seconds from the start when no operation is made in the time.

Just after pressing button B "Err" indicator

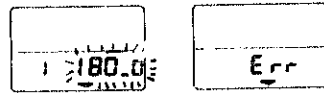

CHECK WATER RESISTANCE (only for Cal. S101A)

- Use the Air-pressure Water Resistance Tester S-451.

CHECK ALL THE SEGMENTS LIT UP

- Push buttons B and C at the same time in the time and calendar setting function.
- The display returns to the time and calendar display by pushing button A.

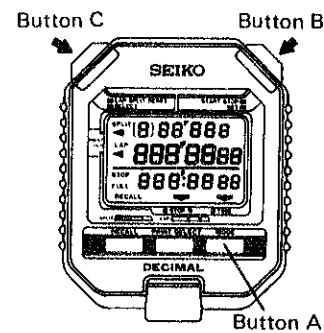

I. SPECIFICATIONS

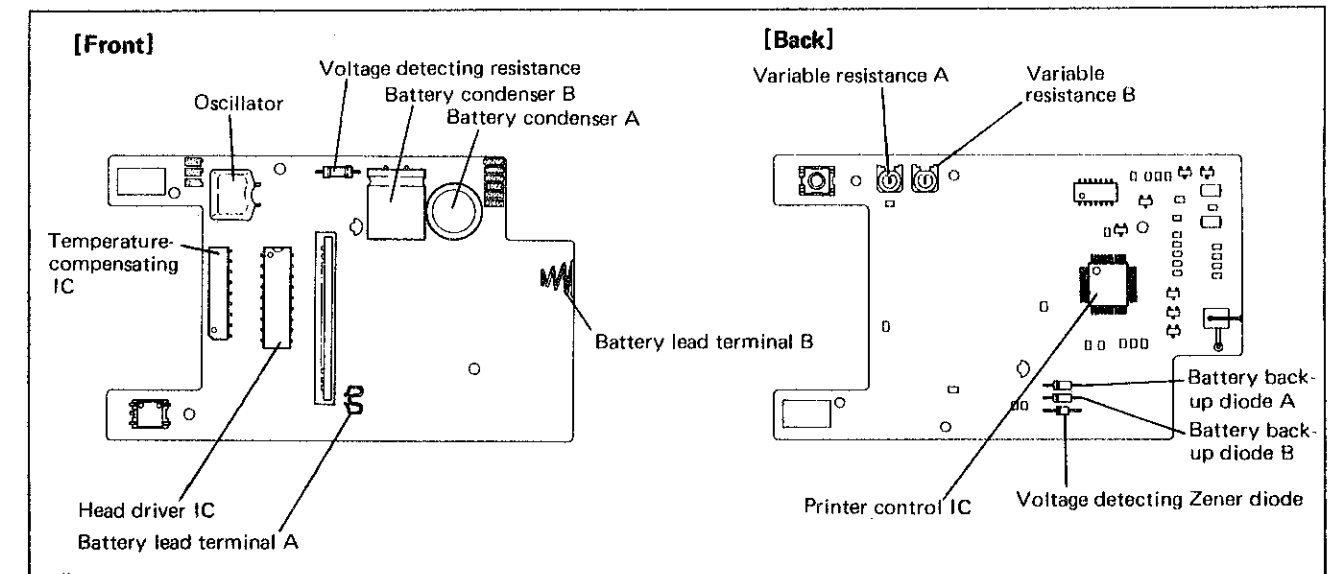

Item	Cal. No.	System printer SP11
Printing system		Thermal type serial dot
Printing function		13 digits/line (including space) Numerals, alphabets, +, -, x, ÷, =, %, !, :, ', ", / Printing speed is approximately 0.7 line/second.
Outside diameter		126.0 (H) x 75.0 (W) x 23.4 (T) mm
Battery		IEC Designation R6 or LR-6 (size AA) battery, 3 pcs.
Battery voltage		1.5V
Battery life		R-6 battery: Approx. 3,000 lines (Approx. 4 rolls) LR-6 battery: Approx. 6,000 lines (Approx. 8 rolls) (When the printer is connected with the Stopwatch Cal. S111A or S119A and used at 24°C)
Paper (roll paper)		Thermal paper Width: 38 mm, Diameter of roll: φ18 mm Max.

II. STRUCTURE OF THE CIRCUIT BLOCK

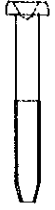

All procedures of Disassembling, Reassembling, Lubricating, Checking and Adjustment are completed.

III. LIST OF THE SCREWS USED

Shape	Part No.	Name	Shape	Part No.	Name
	8150 1983	Screw A (3 pcs.) (for back cover)		8150 2003	Screw B (1 pc.) (for battery compartment)
				8150 2022	Screw C (1 pc.) (for circuit block)

IV. DISASSEMBLING AND REASSEMBLING OF THE SYSTEM PRINTER SP11

1. Roll paper setting block

Disassembling procedures Figs.: ① → ③

Reassembling procedures Figs.: ③ → ①

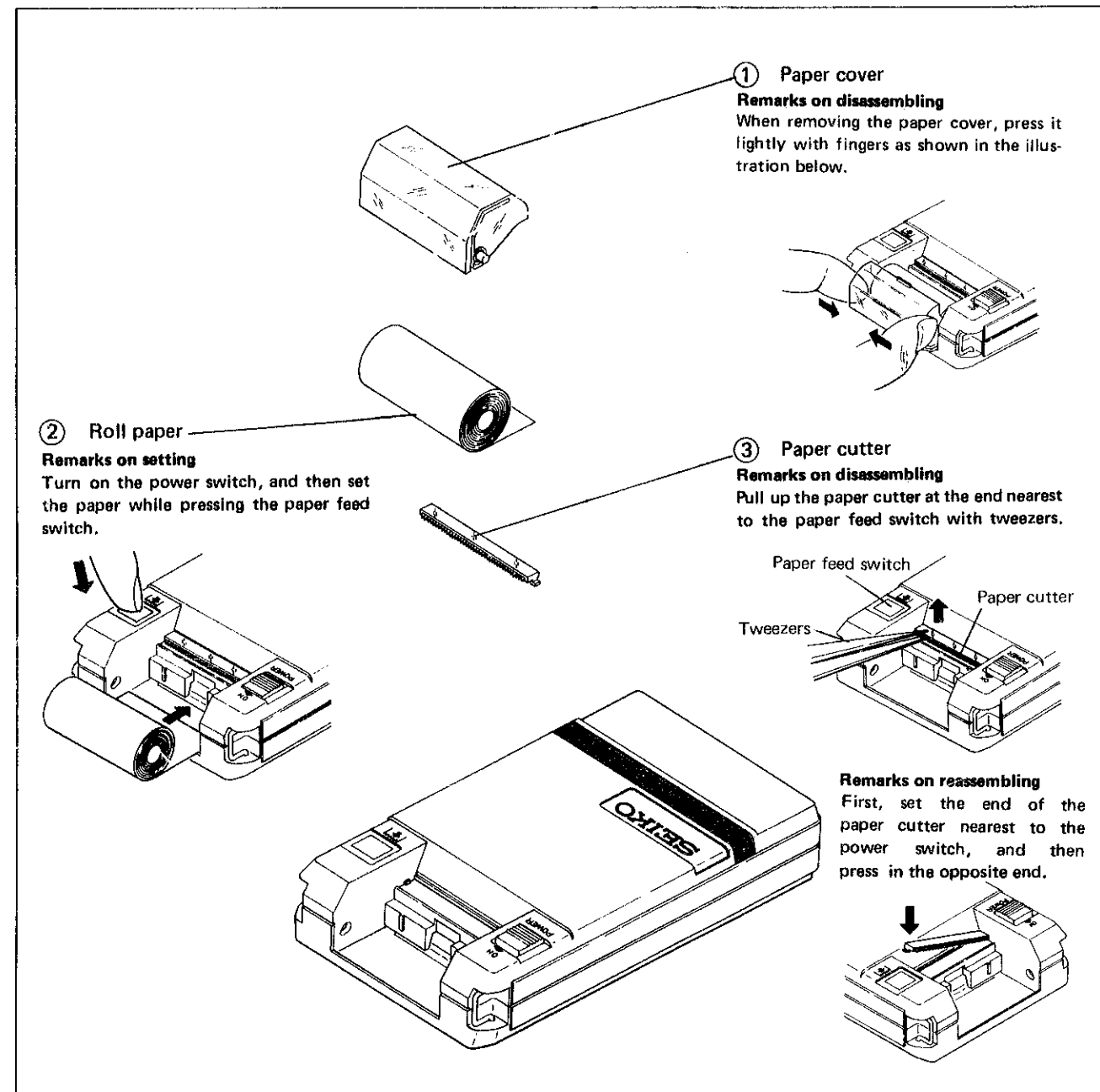

2. Battery hatch ~ Holder

Disassembling procedures Figs.: ① → ⑭

Reassembling procedures Figs.: ⑭ → ①

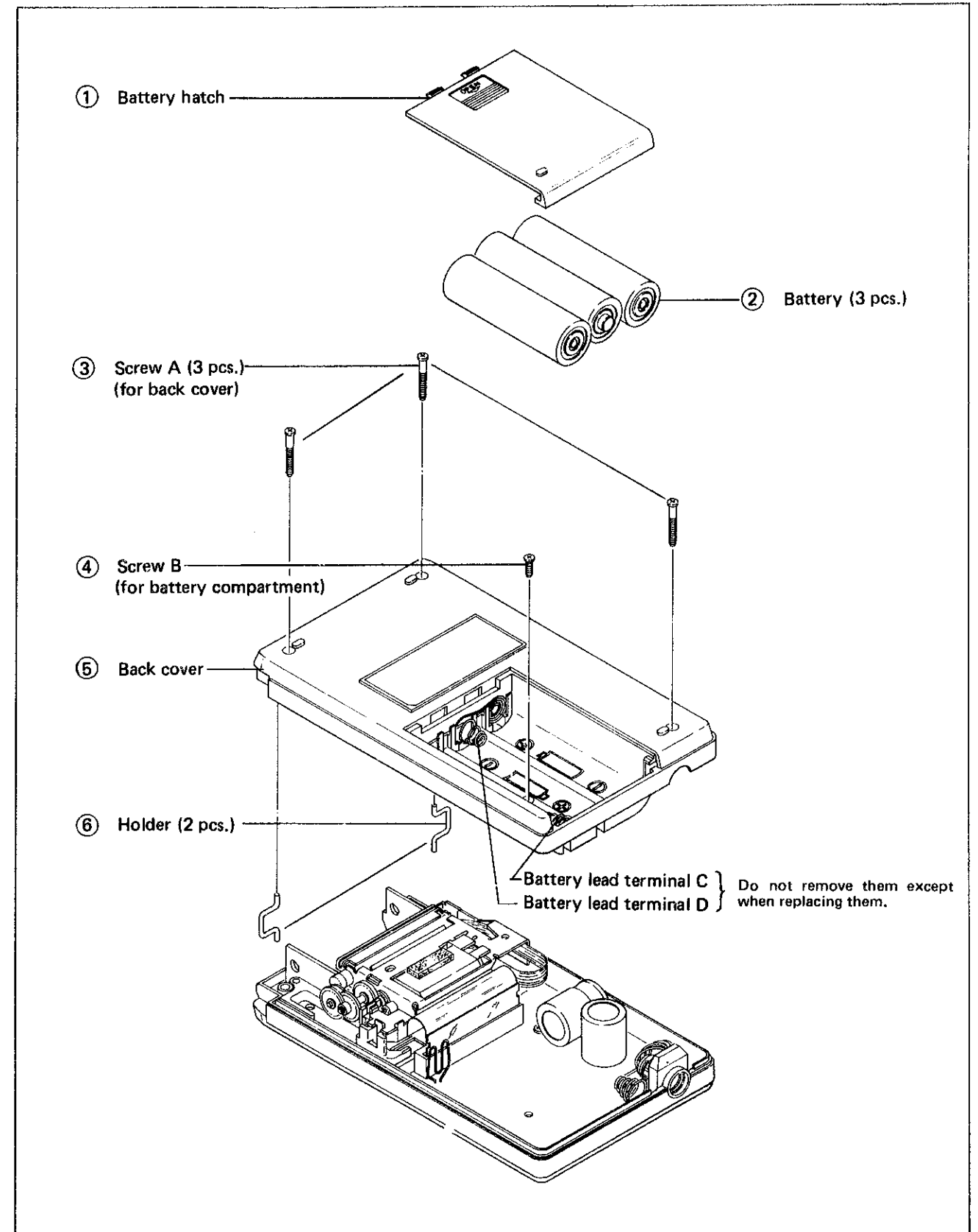

3. Printer unit ~ Front cover

⑦ Printer unit

Remarks on disassembling
When removing the printer unit from the circuit block, hold it at the "A" part with fingers and pull it up softly.

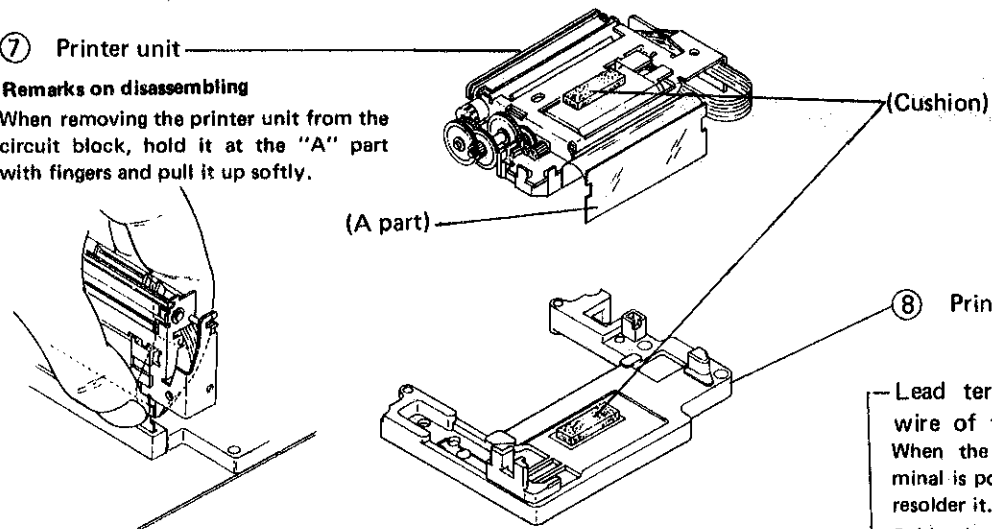

⑨ Screw C (for circuit block)

Remarks on reassembling
Power switch has lead wires to be soldered to the lead terminal on the circuit block. Solder in the order of "red, white, and blue".

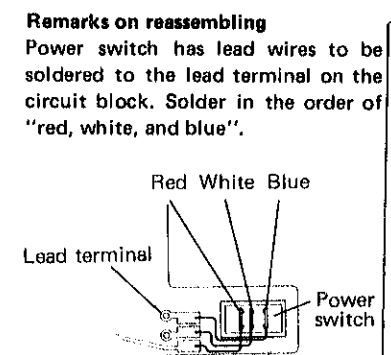

⑩ Switch cover A

Do not remove the switch cover A except when replacing it.

Remarks on reassembling
Make sure that the protrusion of the power switch is set in the square hole of the switch cover A.

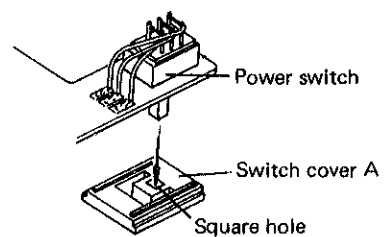

⑧ Printer guide frame

Lead terminal (where the lead wire of the outlet is soldered)
When the conductivity of lead terminal is poor, remove the solder and resolder it.

Solder in the order of "black, red, white, green, blue, and yellow."

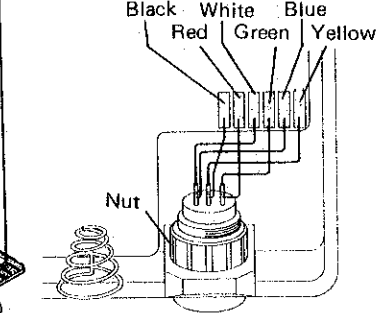

⑫ Circuit block

⑬ Switch cover B (for paper feed switch)

⑭ Front cover

Outlet
Nut
Battery terminal B
Battery terminal A

Do not remove them except when replacing them.

V. CORD

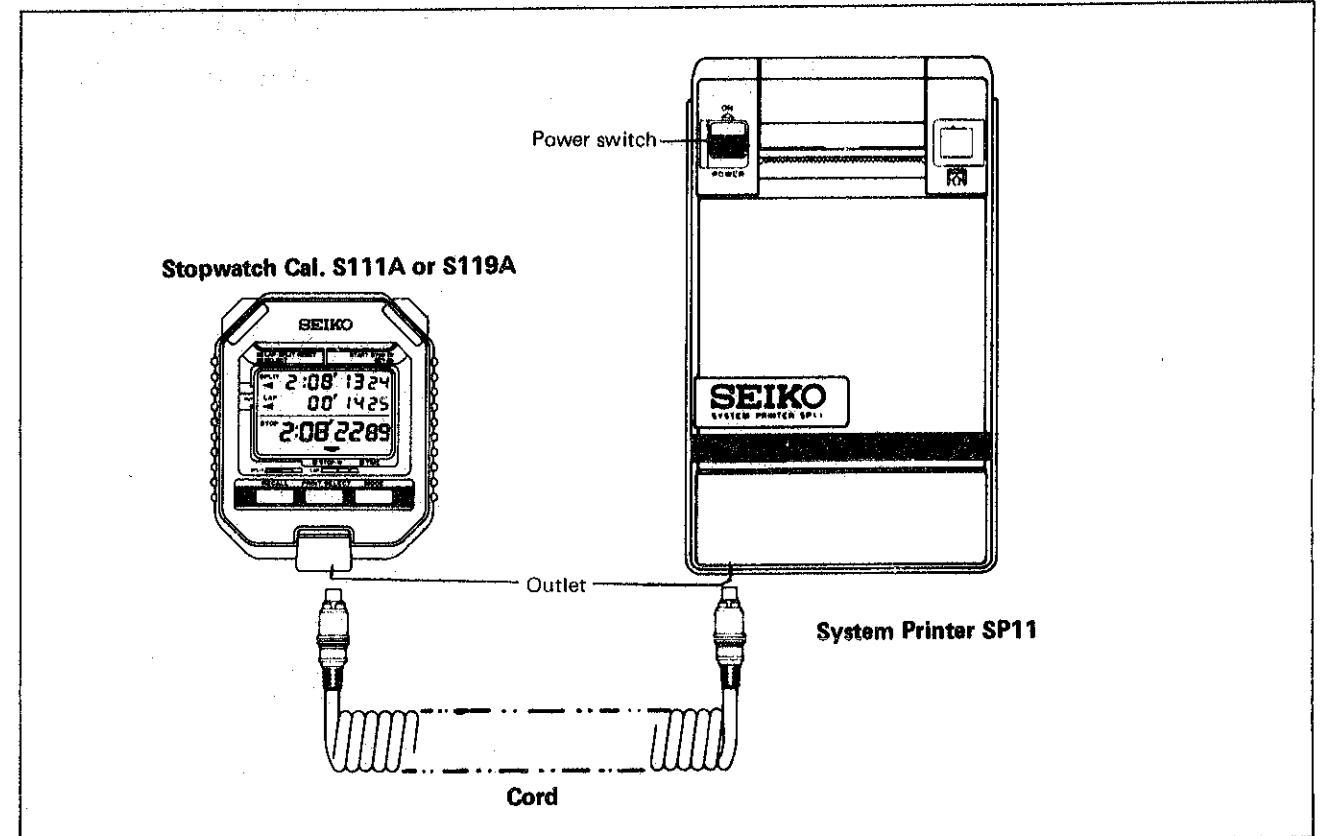

How to connect the cord

Holding the cord with fingers as designated in the illustration on the right, insert its plugs into the outlet of the stopwatch and that of the printer respectively until they click fixed. The guide groove is provided on the plugs of the cord, and it should be inserted in position.

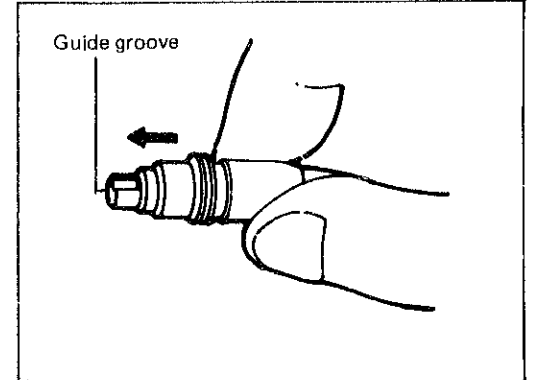

How to take off the cord

After use, turn off the printer's power switch and then unplug the cord from the watch and the printer, holding it with fingers as designated in the illustration on the right.

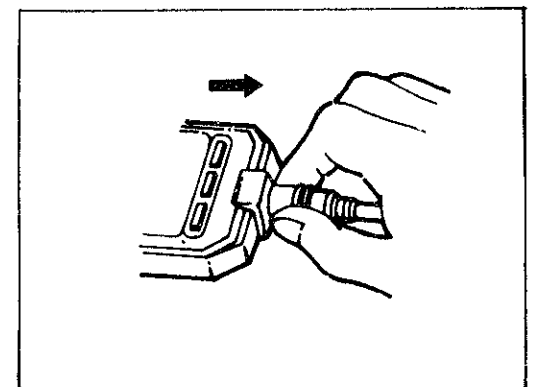

● Guide table for checking and adjustment of printer

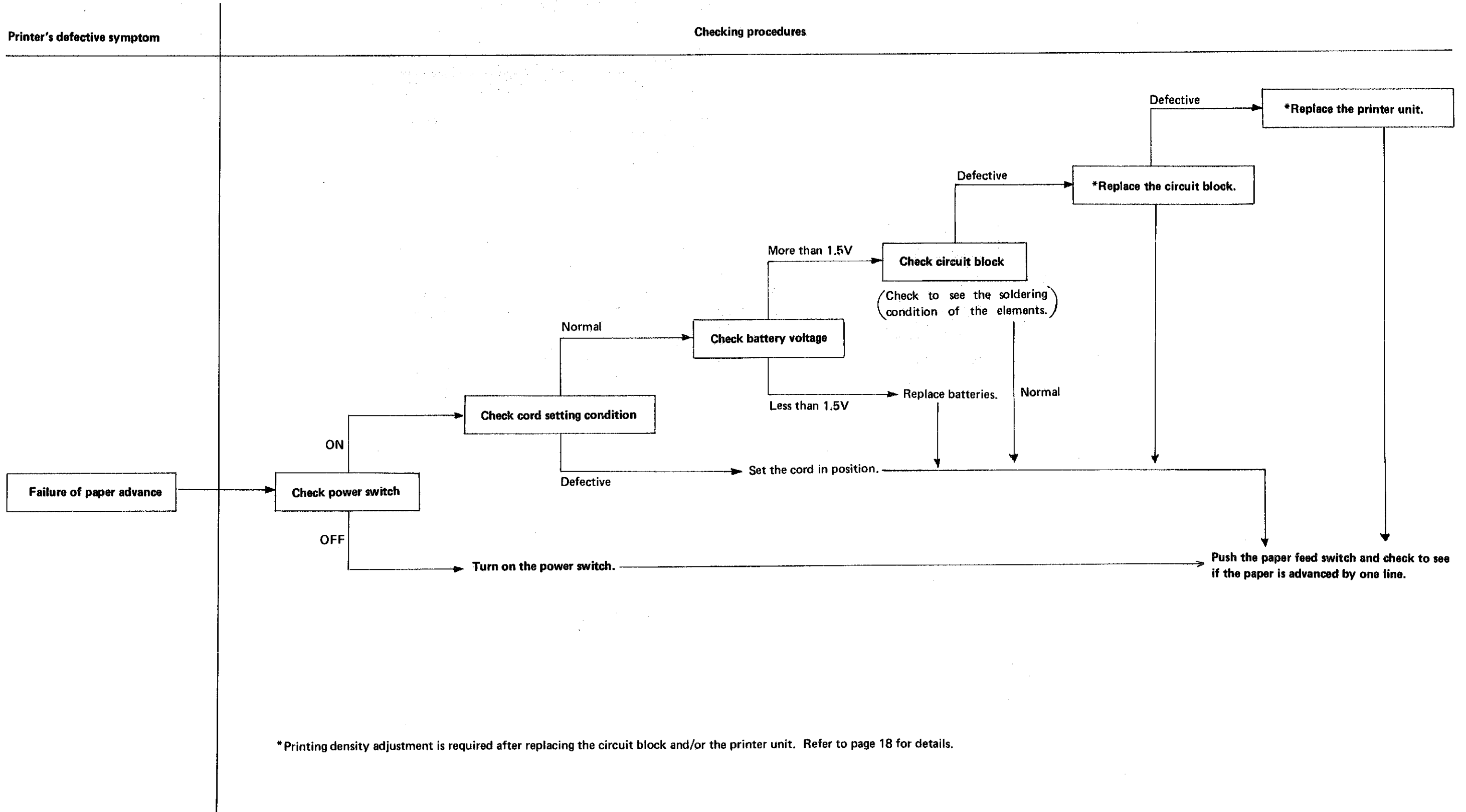

* Printing density adjustment is required after replacing the circuit block and/or the printer unit. Refer to page 18 for details.

Printer's defective symptom

Checking procedures

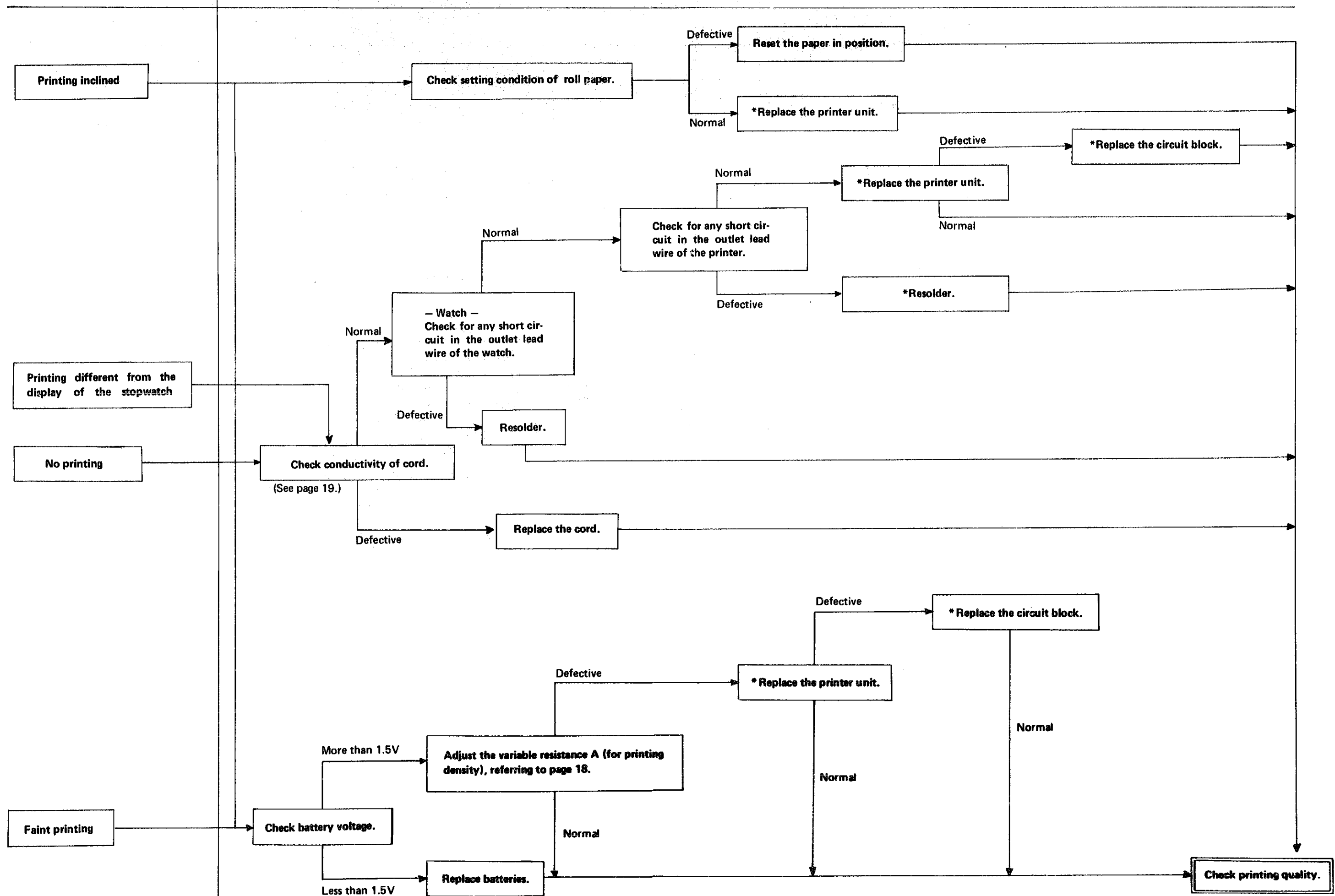

* Printing density adjustment is required after replacing the circuit block and/or the printer unit. Refer to page 18 for details.

HOW TO ADJUST THE PRINTING DENSITY

1. Turn the variable resistance A on the circuit block with a screwdriver and adjust the printing density.

To make dense: Clockwise

To make light: Counterclockwise

2. Check the printing density again after reassembling.

If the density of the letters is adjusted to too dark, it will cause the printer to consume excess current.

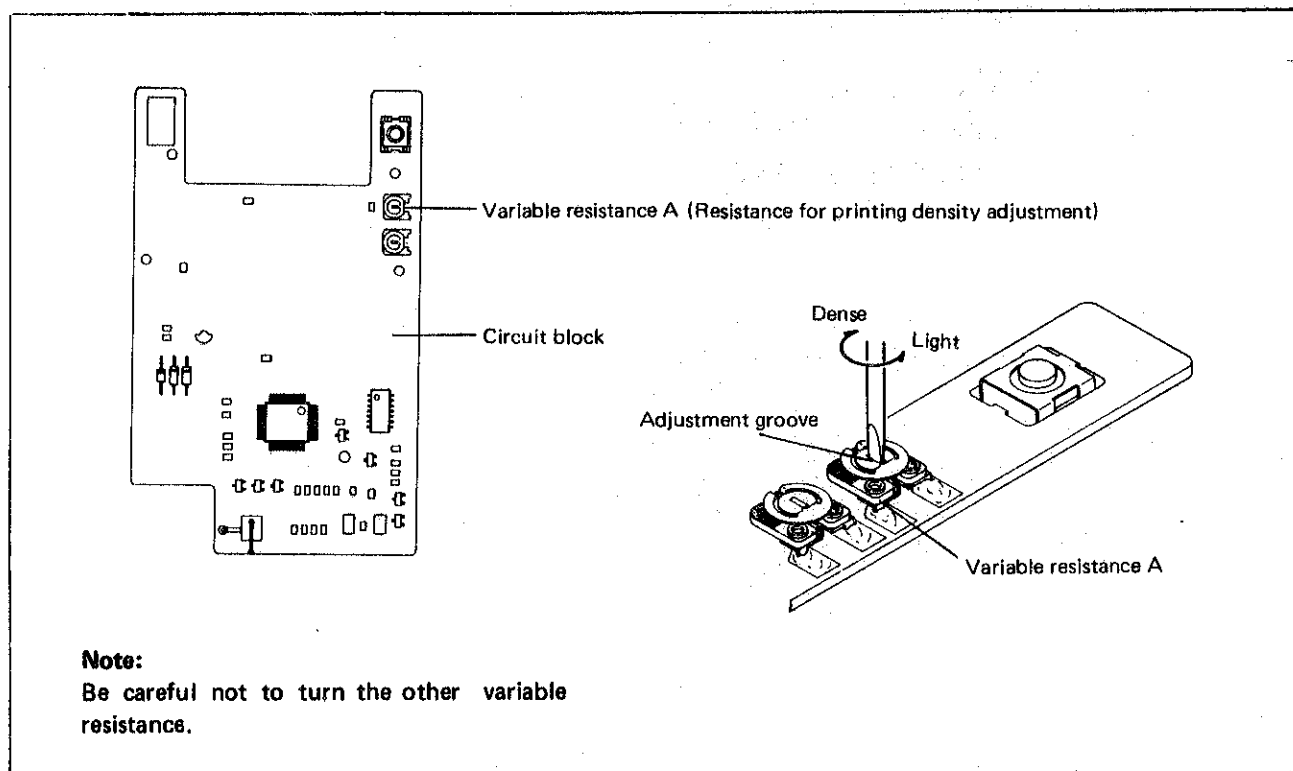

● **In case of adjustment after replacing the printer unit only.**

Printer unit shows A, B, C or D on its "A part" described in the illustration on page 14 to identify the degree of printing density. And the printing density becomes heavy in the order of A, B, C and D. Adjustment is not required when the degree of the old and the new printer units are same or near to each other.

● **In case of adjustment after replacing the circuit block only.**

Set the adjustment groove of the variable resistance A in the same position as that of the old circuit block.

HOW TO CHECK CONDUCTIVITY OF THE CORD

Insert metal rods or thick wires in the corresponding holes of the plugs at both ends of cord and apply the probes of the tester to the metal rods.

