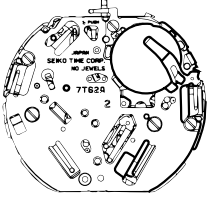
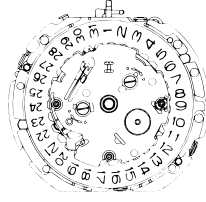

PARTS CATALOGUE/TECHNICAL GUIDE

Cal. 7T62A/7T92A/7T94A

[SPECIFICATIONS]

Cal. No.		7T62A	7T92A	7T94A
Item				
Movement				
		The illustrations refer to Cal. 7T62A.		(x 1.0)
Movement size	Outside diameter	Ø 27.6 mm		
	Casing diameter	Ø 27.0 mm		
	Height	3.3 mm		
Time indication	Main time	Hour, minute and small second hands		
	Stopwatch	Minute hand 1/5-second hand (Moves at 0.2-second intervals.)	Hour and minute hands Second hand 1/20-second hand (Moves at 0.05-second intervals.)	Minute hand 1/5-second hand (Moves at 0.2-second intervals.)
	Alarm	Hour and minute hands (Minute hand moves at 1-minute intervals.)	_____	
Driving system		Step motor (Load compensated driving pulse type)		
		4 pcs.	3 pcs.	4 pcs.
Additional mechanism		<ul style="list-style-type: none"> • Electronic circuit reset switch • Train wheel setting device • Date calendar • Instant setting device for date calendar • Battery life indicator 		
		<ul style="list-style-type: none"> • Stopwatch function • Measures up to 60 minutes in 1/5-second increments. • Accumulated elapsed time measurement • Split time measurement 	<ul style="list-style-type: none"> • Stopwatch function • Measures up to 12 hours in 1/20-second increments. • Accumulated elapsed time measurement • Split time measurement 	<ul style="list-style-type: none"> • Stopwatch function • Measures up to 60 minutes in 1/5-second increments. • Accumulated elapsed time measurement • Split time measurement
		• Single-time alarm function _____		
Loss/gain		Monthly rate at normal temperature range: less than 15 seconds		
Regulation system		Nil		
Measuring gate by quartz tester		Use 10-second gate.		
Battery	Battery No.	SEIKO SR927W, SONY SR927W, Maxell SR927W, Matsushita SR927W	SEIKO SR927SW, SONY SR927SW, Maxell SR927SW, Matsushita SR927SW	
	Voltage	1.55 V		
	Battery life	Approx. 3 years	Approx. 5 years	Approx. 3 years
Jewels		Nil		

SEIKO WATCH CORPORATION

REMARKS ON REPAIRING CAL. 7T62A/7T92A/7T94A

Unlike the other Cal. 7T Series watches, which have two crowns and three buttons, Cal. 7T62A, Cal. 7T92A and Cal. 7T94A have one crown and two buttons. But their basic movement structure is similar in other respects, and the knowledge and technique you have gained in handling the previous Cal. 7T Series watches will come in handy when you repair Cal. 7T62A, 7T92A as well as 7T94A.

When repairing, however, you are requested to have the full knowledge of the features characteristic of these watches and strictly observe the repairing and checking instructions provided in this guide so that the watches will be repaired correctly.

FEATURES

As Cal. 7T62A/7T92A/7T94A has fewer crowns and buttons, the operating procedures for alarm setting (for Cal. 7T62A only), time setting and stopwatch hand position adjustment differ from those of the other Cal. 7T Series watches.

As a result of this structure change, the battery life of Cal. 7T62A/7T92A/7T94A has increased by one year to 3 years as compared with that of the other Cal. 7T series watches.

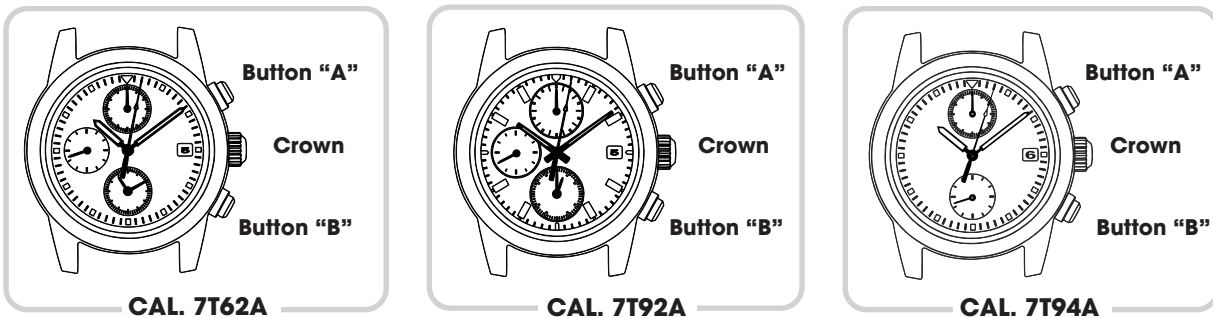

1. STOPWATCH FUNCTION

● Measurement performance

Cal. 7T62A and 7T94A: Measures up to 60 minutes in 1/5 second increments.

Displays the elapsed time with the stopwatch minute and 1/5-second hands.

Cal. 7T92A: Measures up to 12 hours in 1/20 second increments.

Displays the elapsed time with the stopwatch hour, minute, second and 1/5-second hands.

● Button operation

Standard Measurement



Accumulated Elapsed Time Measurement



Split Time Measurement





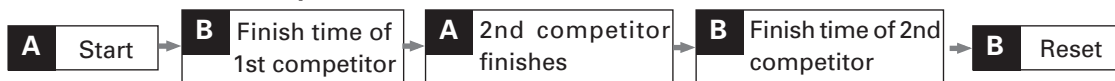



Measurement of Two Competitors

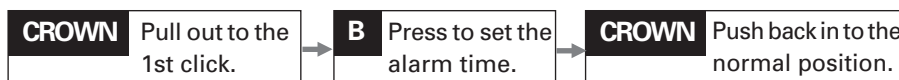

2. ALARM FUNCTION (For Cal. 7T62A only)

- The alarm sounds only once at a designated time within the coming 12 hours and it is automatically disengaged.
- Pushing the crown back into the normal position after setting the alarm will prevent the set alarm time from changing by an accidental pressing of the button.



Disassembling procedures Figs. :	① → ⑤⑤
Reassembling procedures Figs. :	⑤⑤ → ①
Lubricating: Types of oil	Oil quantity
Moebius A 	Normal quantity 
Moebius F 	Liberal quantity 
SEIKO Watch Oil S-6 	

The illustration refers to Cal. 7T62A, 7T92A and 7T94A.

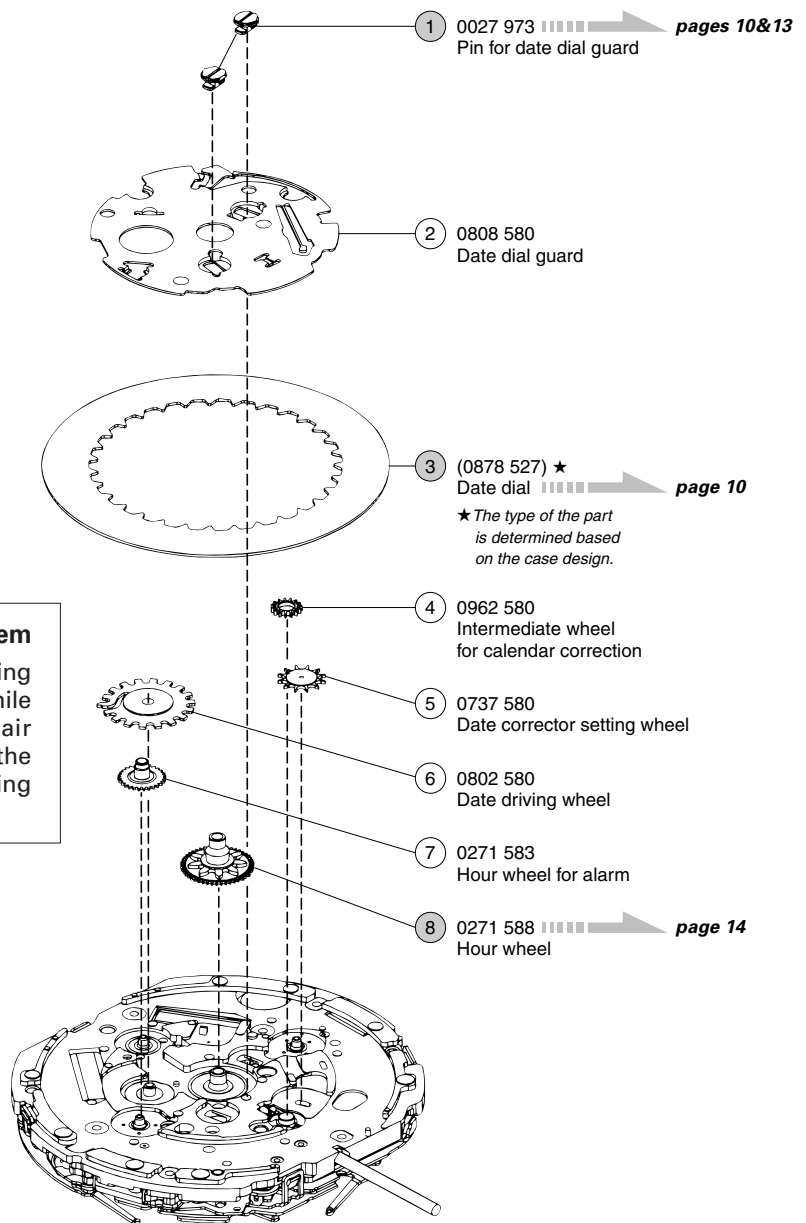

Remarks on removing the winding stem



To remove the winding stem when taking out the movement from the case or while disassembling the parts during repair work, be sure to pull out the crown to the first click, and then, remove the winding stem while pushing the setting lever.

 Please see the remarks on the following pages.

Lubricating of some parts is shown in "II. REMARKS ON DISASSEMBLING AND REASSEMBLING."

PARTS CATALOGUE

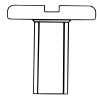
Cal. 7T62A/7T92A/7T94A

	0022 230 • Battery clamp screw (2 pcs.)
	0022 459 • Circuit block cover screw (4 pcs.)

The illustration refers only to Cal. 7T62A.

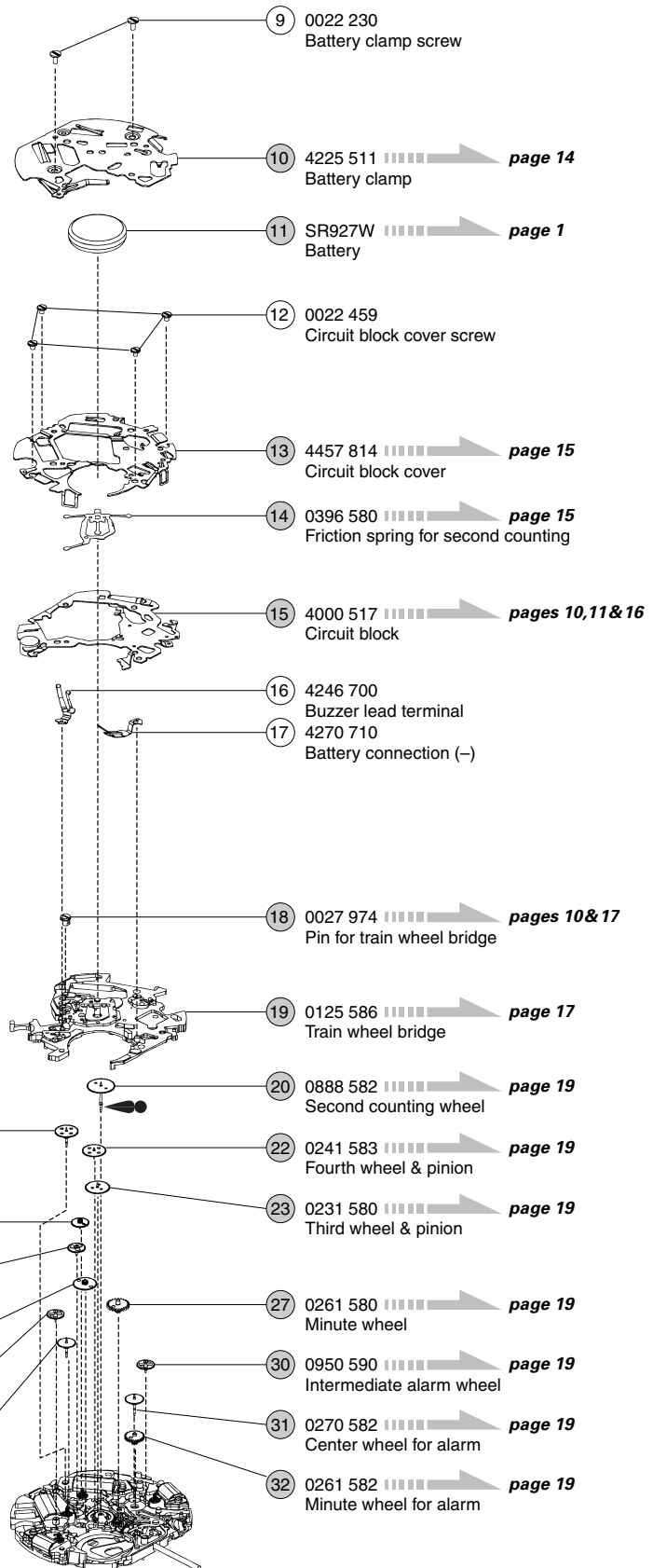
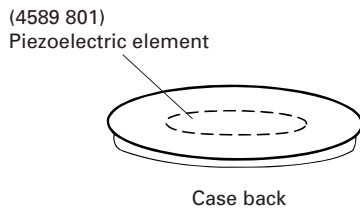

 Please see the remarks on the following pages.

Lubricating of some parts is shown in "II. REMARKS ON DISASSEMBLING AND REASSEMBLING."

The illustration refers only to Cal. 7T62A.

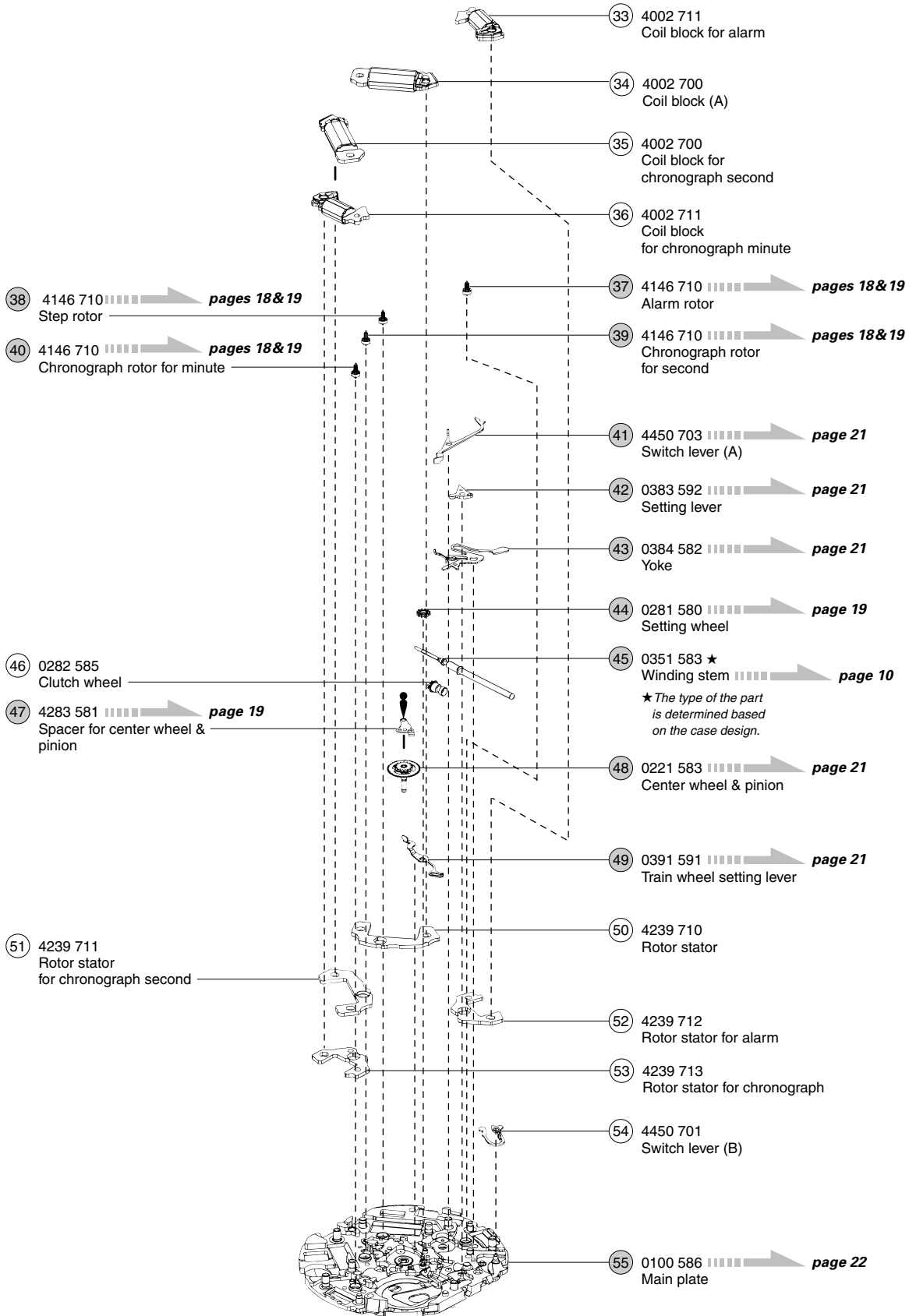

Please see the remarks on the following pages.

Lubricating of some parts is shown in "II. REMARKS ON DISASSEMBLING AND REASSEMBLING."

PARTS CATALOGUE

Cal. 7T62A/7T92A/7T94A

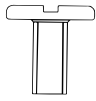
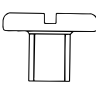
	0022 230 • Battery clamp screw (2 pcs.)
	0022 459 • Circuit block cover screw (4 pcs.)

The illustration refers only to Cal. 7T92A.

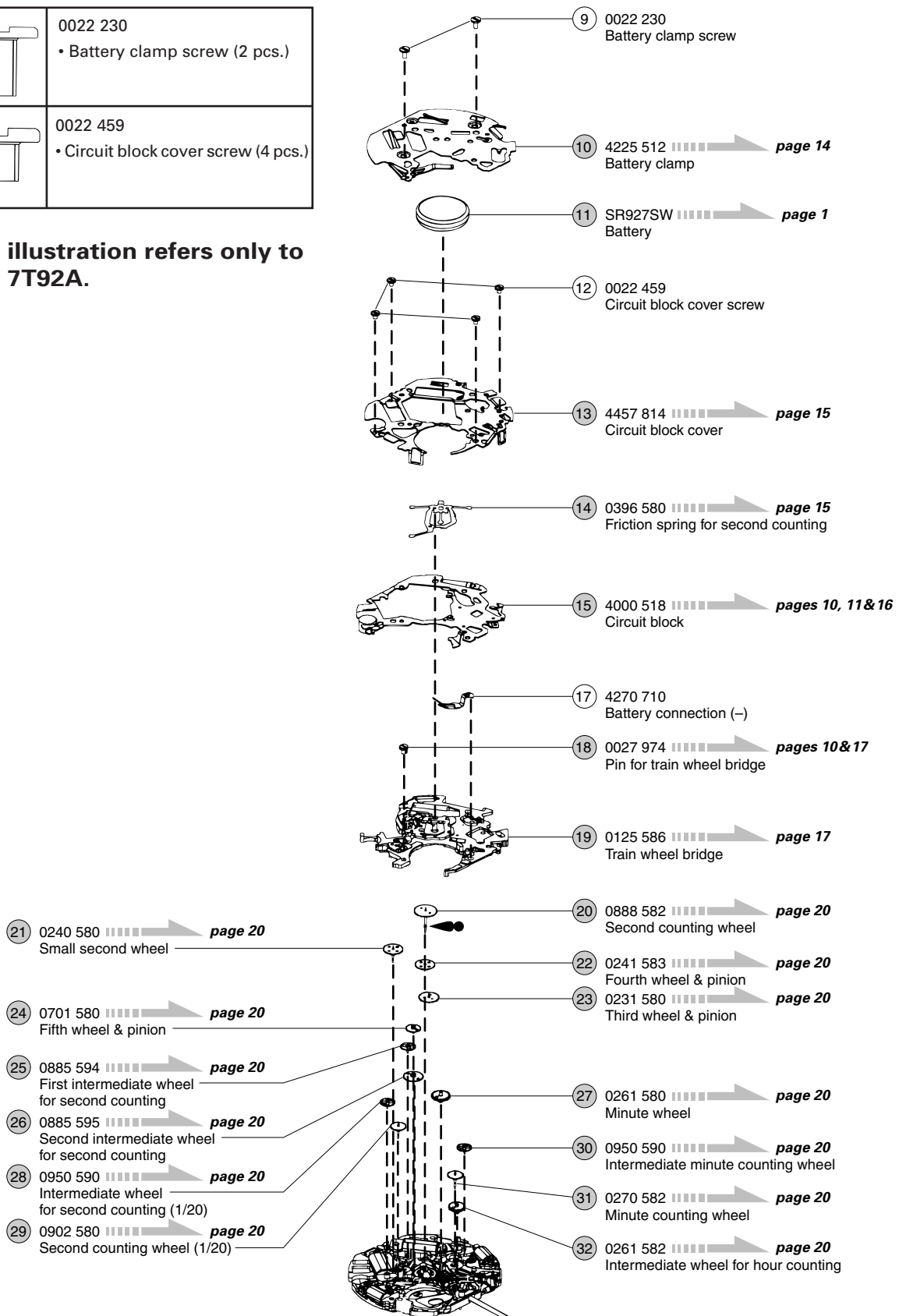

 Please see the remarks on the following pages.

Lubricating of some parts is shown in "II. REMARKS ON DISASSEMBLING AND REASSEMBLING."

The illustration refers only to Cal. 7T92A.

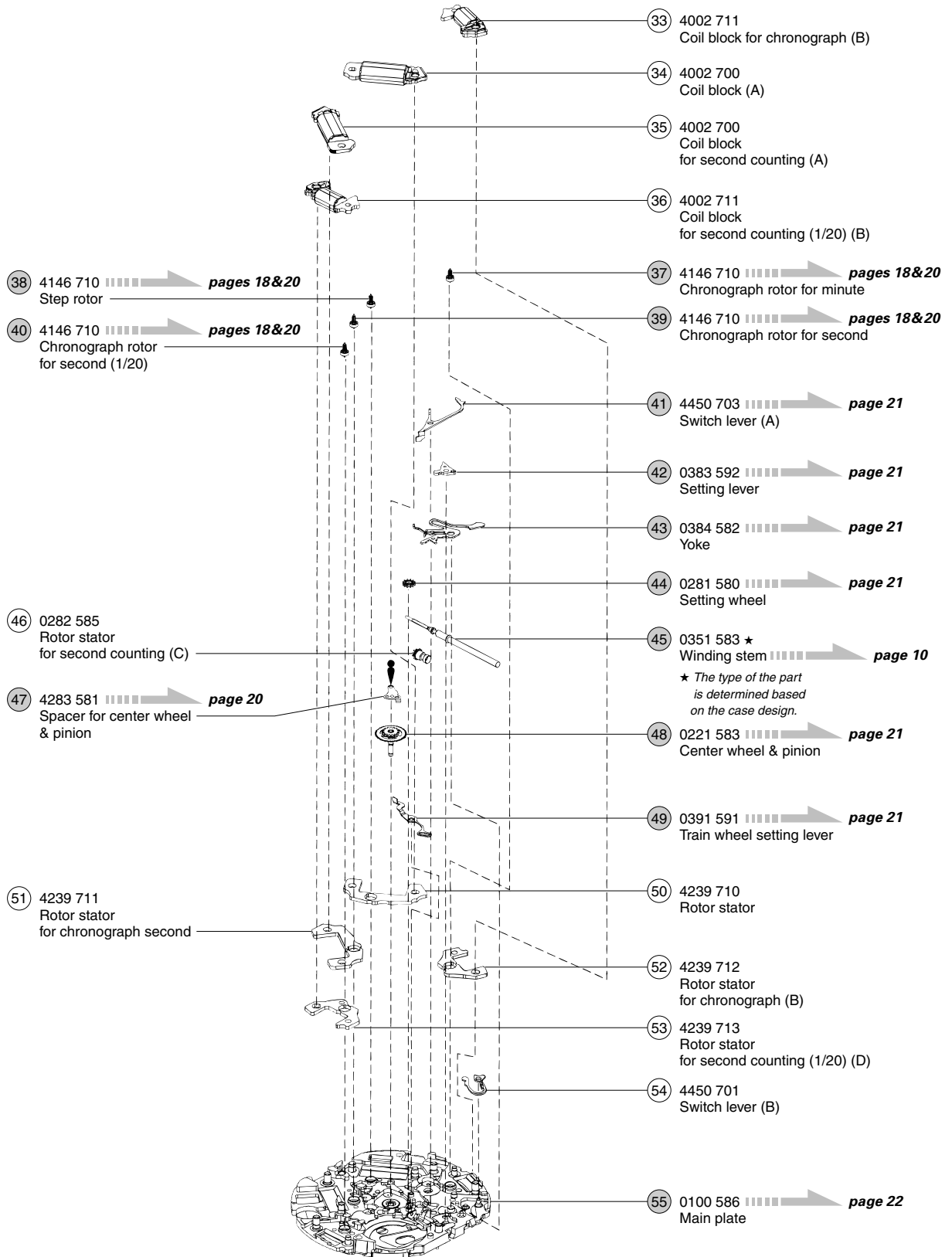



☉ ⇨ Please see the remarks on the following pages.

Lubricating of some parts is shown in "II. REMARKS ON DISASSEMBLING AND REASSEMBLING."

PARTS CATALOGUE

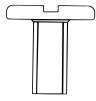
Cal. 7T62A/7T92A/7T94A

	0022 230 • Battery clamp screw (2 pcs.)
	0022 459 • Circuit block cover screw (4 pcs.)

The illustration refers only to Cal. 7T94A.

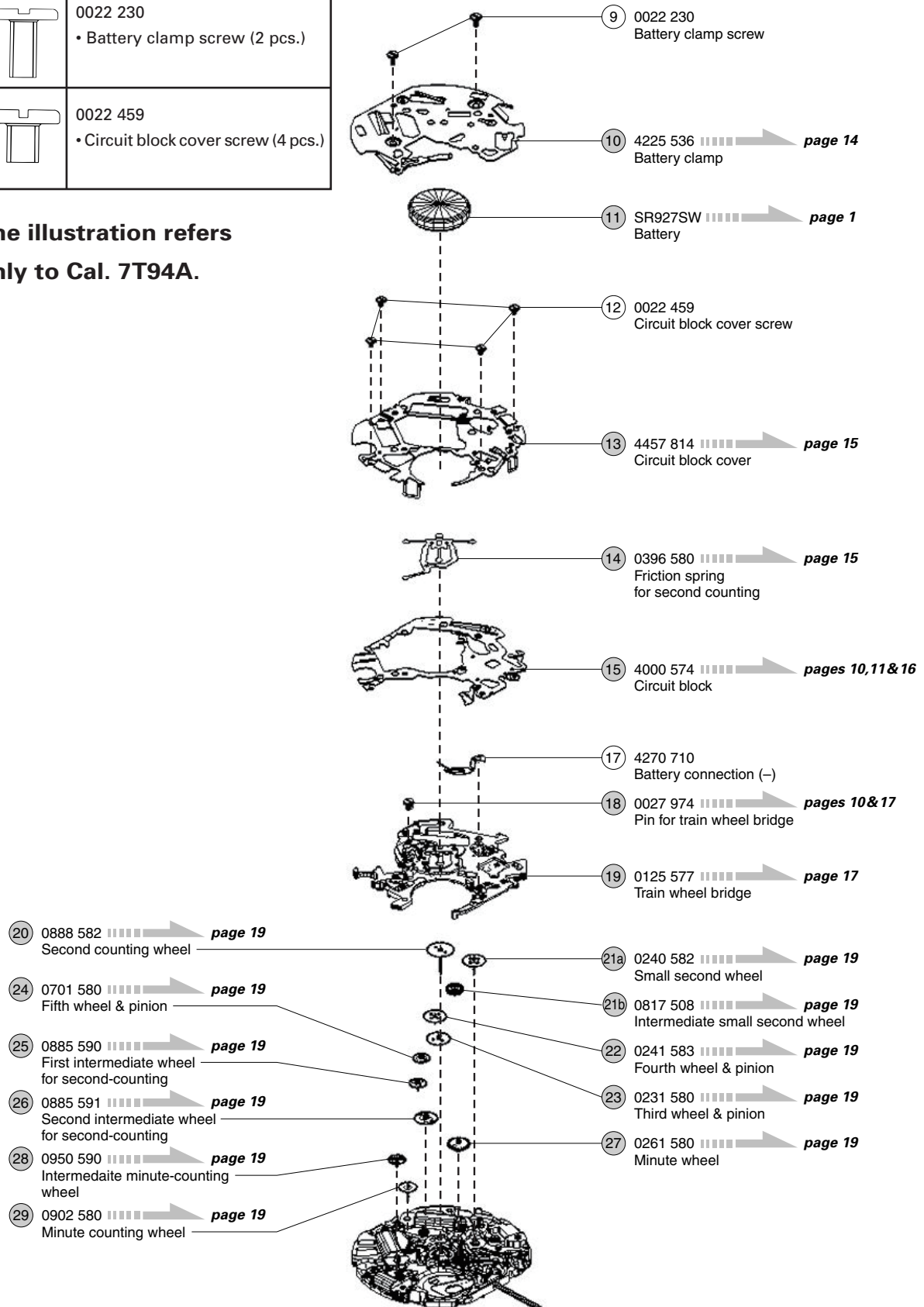

☉ ⇨ Please see the remarks on the following pages.
 Lubricating of some parts is shown in "II. REMARKS ON DISASSEMBLING AND REASSEMBLING."

The illustration refers only to Cal. 7T94A.

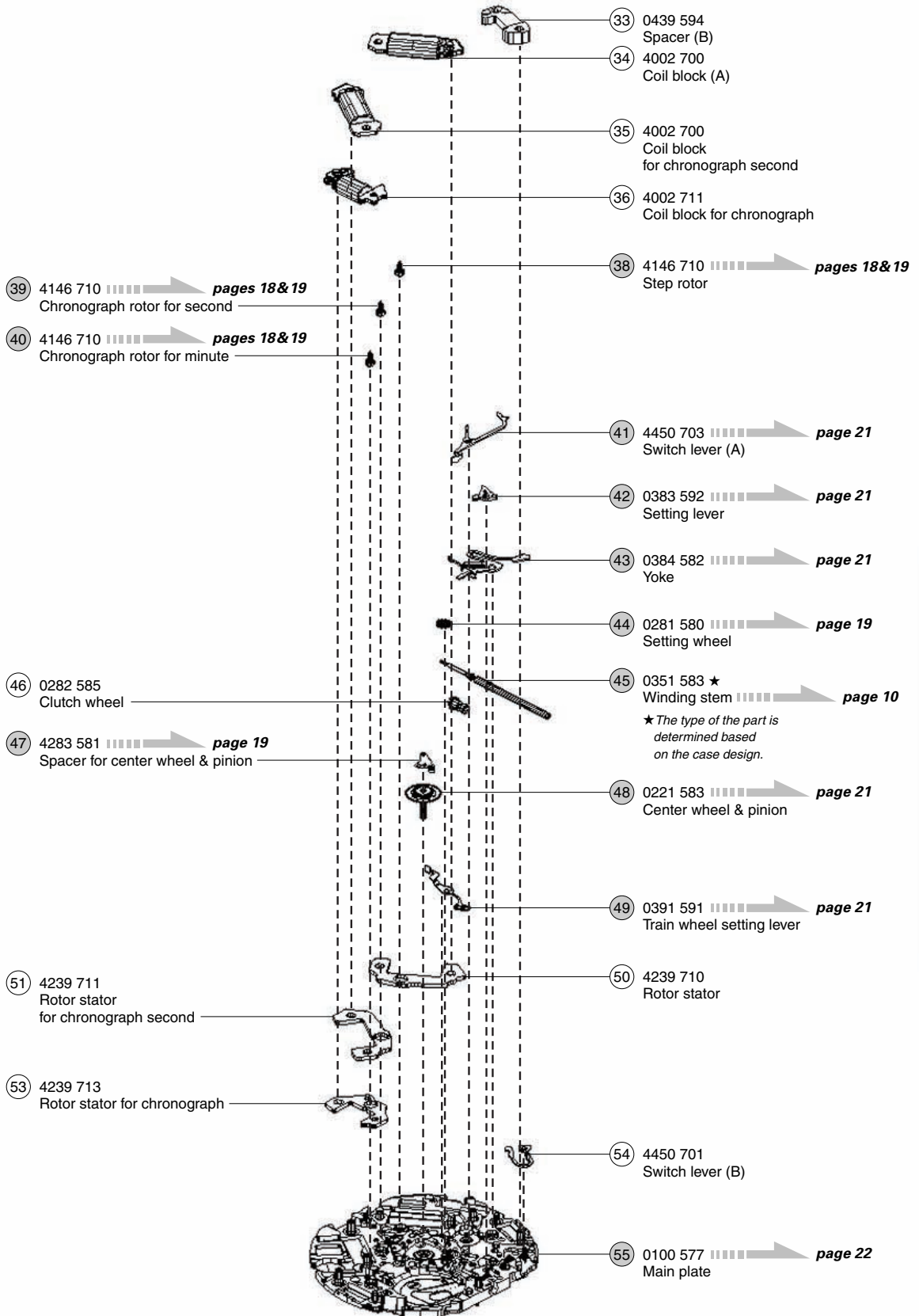

Please see the remarks on the following pages.

Lubricating of some parts is shown in "II. REMARKS ON DISASSEMBLING AND REASSEMBLING."

Remarks

* Holding ring for dial 0866 650

③ Date dial 0878 527

④⑤ Winding stem 0351 583

The types of the above parts are determined based on the design of cases. Check the case number, and refer to "Casing Parts Catalogue" to choose corresponding parts.

① Pin for date dial guard 0027 973

⑧ Pin for train wheel bridge 0027 974

• **Point of distinction**

[Pin for date dial guard]

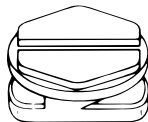

[Pin for train wheel bridge]

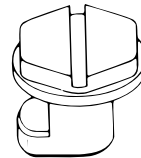

⑮ Circuit block

The circuit blocks have a hole for discrimination as shown in the illustrations below.

* The holes for discrimination are intended to discriminate among the circuit blocks for Cal. 7T62A, Cal. 7T92A and Cal.7T94.

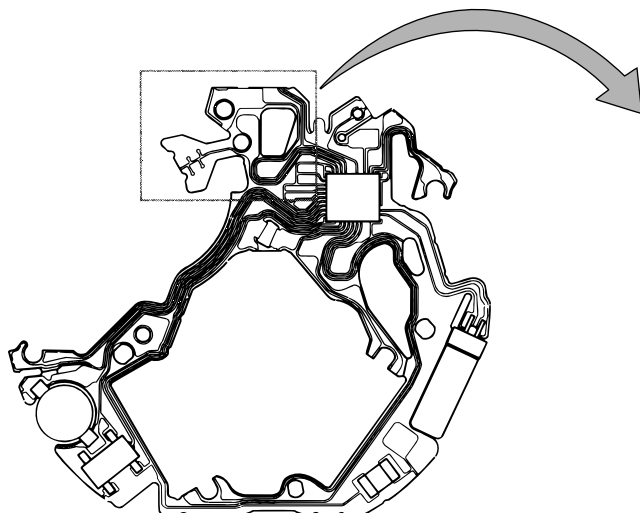

CAL. 7T62A
No hole
CAL. 7T92A
Hole
CAL. 7T94A
Hole

- The explanation here is only for the particular points of Cal. 7T62A, 7T92A and 7T94A.
- For the repairing, checking and measuring procedures, refer to the "TECHNICAL GUIDE, GENERAL INSTRUCTIONS."

I. STRUCTURE OF THE CIRCUIT BLOCK

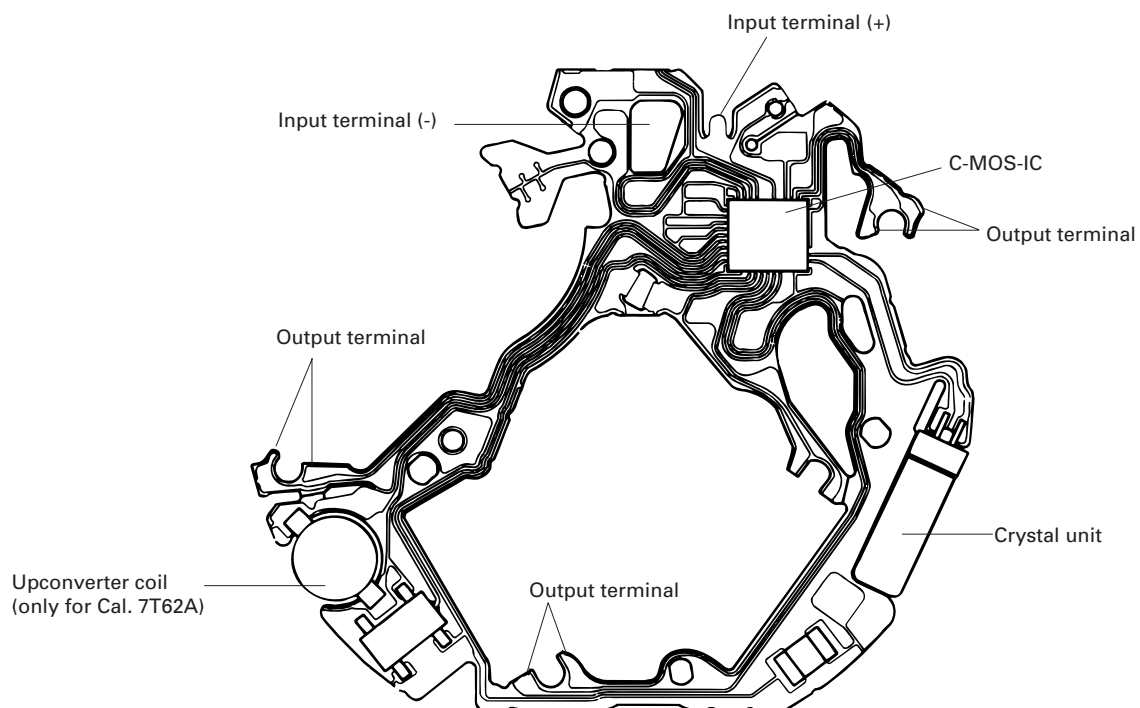

II. NECESSARY PROCEDURE AFTER BATTERY CHANGE

After installing the battery, set the time and reset the stopwatch hands to the "0" position following the procedure below.



CROWN Pull out to the 2nd click when the small second hand is at the 12 o'clock position.

CROWN Turn to set the time hands to the current time.
* Check that AM/PM is correctly set.

B Press to set the alarm hands to the current time.

A Press for 2 seconds.
* The stopwatch minute hand turns a full circle.

B Press to set the stopwatch minute hand to the "0" position.

A Press for 2 seconds.
* The stopwatch second hand turns a full circle.

B Press to set the stopwatch 1/5-second hand to the "0" position.

A Press for 2 seconds.
* The stopwatch 1/20-second hand turns a full circle.

B Press to set the stopwatch 1/20-second hand to the "0" position.

A Press for 2 seconds.
* The stopwatch second hand turns a full circle.

B Press to set the stopwatch second hand to the "0" position.

A Press for 2 seconds.
* The stopwatch hour and minute hands turn a full circle.

B Press to set the stopwatch hour and minute hands to the "0" position.

A Press for 2 seconds.
* The stopwatch minute hand turns a full circle.

B Press to set the stopwatch minute hand to the "0" position.

A Press for 2 seconds.
* The stopwatch second hand turns a full circle.

B Press to set the stopwatch 1/5-second hand to the "0" position.

CROWN Push back in to the normal position in accordance with a time signal.

* Pressing Button "A" for 2 seconds can resume the procedure again as indicated by the arrow if necessary.

III. REMARKS ON DISASSEMBLING AND REASSEMBLING

● Hands

• Caution for disassembling

The hour wheel is made of engineering plastics. When pulling out the hour hand, take care not to damage the hour wheel.

• How to install

- 1) Pull out the crown with winding stem to the second click. Then, turn the crown clockwise to turn the time hands also clockwise.
- 2) Stop turning the hands when the date changes to the next.
- 3) 7T62: Install the stopwatch minute hand, alarm hour and minute hands so that they point exactly to the 12 o'clock position.
7T92: Install the stopwatch 1/20-second hand, stopwatch hour and minute hands so that they point exactly to the 12 o'clock position.
7T94: Install the stopwatch 1/5-second hand and stopwatch minute hand so that they point exactly to the 12 o'clock position.
- 4) Install the small second, hour and minute hands so that they point exactly to the 12 o'clock position.
- 5) Install the stopwatch hands so that they point exactly to the "0" position of the stopwatch scale.
* After installing the hands, be sure to check that they move smoothly without interfering with one another.

● Dial

• Caution for disassembling

When disassembling the dial, take care not to bend the dial leg. Raise the portions around the dial leg by turns gradually to remove the dial.

① Pin for date dial guard

• How to remove

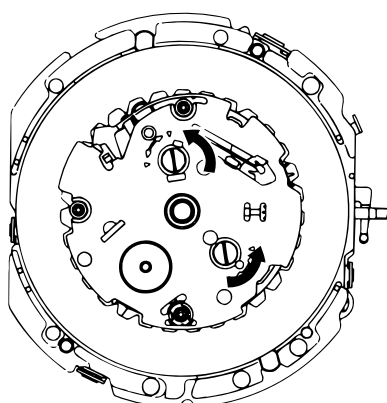

1. Turn the pin 90-degree counterclockwise to loosen the pin using a screwdriver.
2. Pick up the pin using rodico.

• How to install

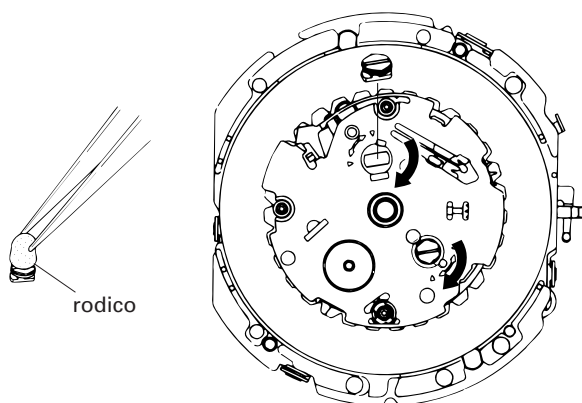

1. Set the pin securely into the groove.
2. Turn the pin 90-degree clockwise to fix the pin using a screwdriver.

Notes:

- * Do not turn the pin more than 90-degree in either direction. Take care so as not to break the plastic parts.
- * Do not turn the pin forcibly.
- * Use a screwdriver of an appropriate size .

- **Lubricating**

After installing the pins for date dial guard, lubricate the wheel edge of both the date driving wheel and date dial.

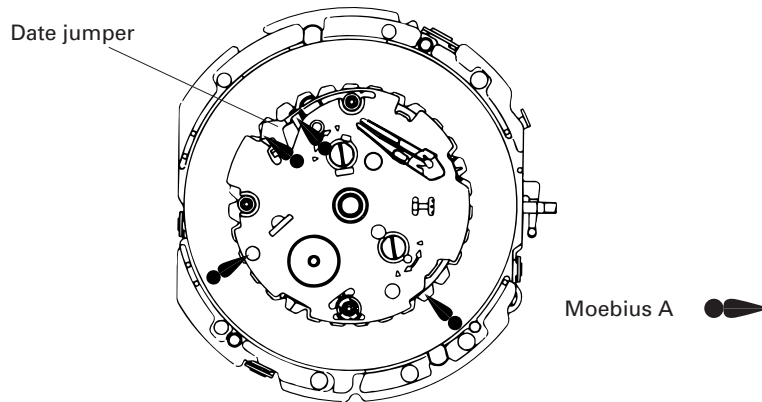

⑧ Hour wheel

When installing the hour wheel, check that it engages with the pinion of the minute wheel.

⑩ Battery clamp

When installing the battery clamp, set it securely to the two hooking portions of the movement.

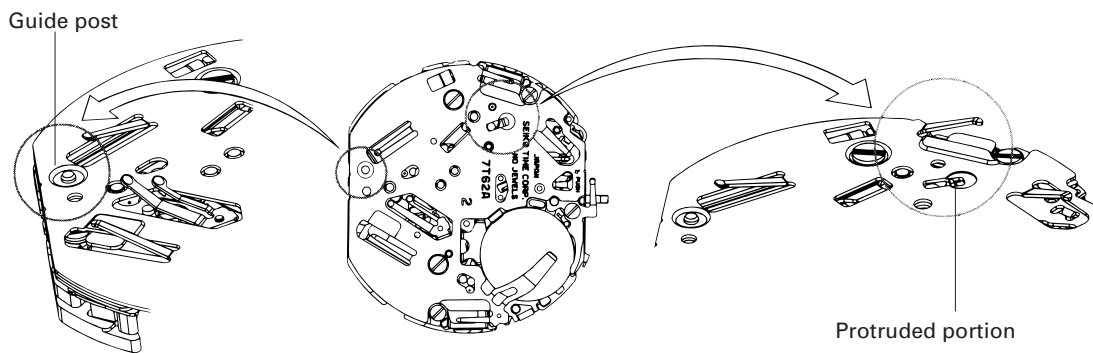

⑬ Circuit block cover

• **How to remove**

- 1) Loosen the four circuit block cover screws.
- 2) Release the four hooking portions of the circuit block cover. (Indicated by the arrows in the illustration below)

• **How to install**

- 1) Have the four hooking portions of the circuit block cover (indicated by the arrows in the illustration below) catch the movement securely. In doing so, check if the circuit block is set properly to guide posts "a" and "b", and reset it in position if necessary.
- 2) Tighten the four circuit block cover screws. When tightening the screws, take care not to cut the coil.

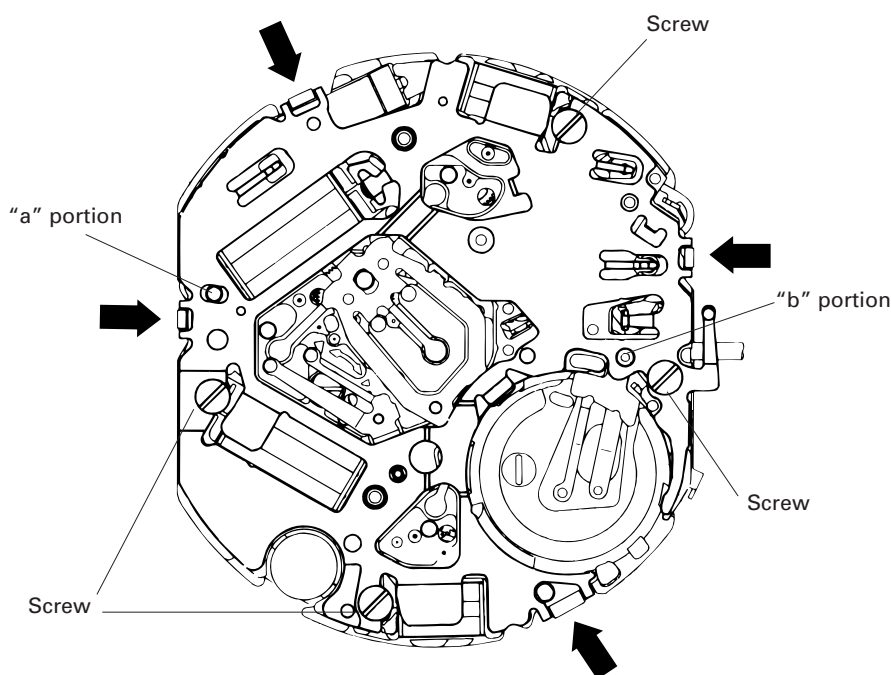

⑭ Friction spring for second counting

• **Setting position**

To set the friction spring for second counting, slip it into the gap under the train wheel bridge.

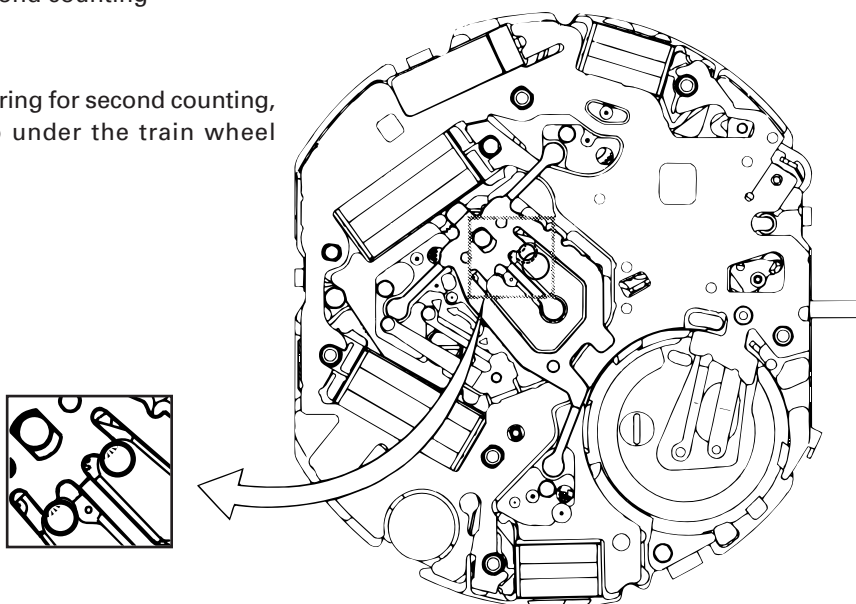

⑮ Circuit block

- **Caution for disassembling**

The circuit block is fixed to the train wheel bridge with the guide pins ("a", "b", "c", "d" and "e" in the illustration shown below). When removing the circuit block from the guide pins, take care not to damage the circuit block.

- **How to install**

Have the guide holes of the circuit block ("a", "b", "c", "d" and "e" portions in the illustration) securely caught by the guide pins of the train wheel bridge and the guide tubes of the main plate.

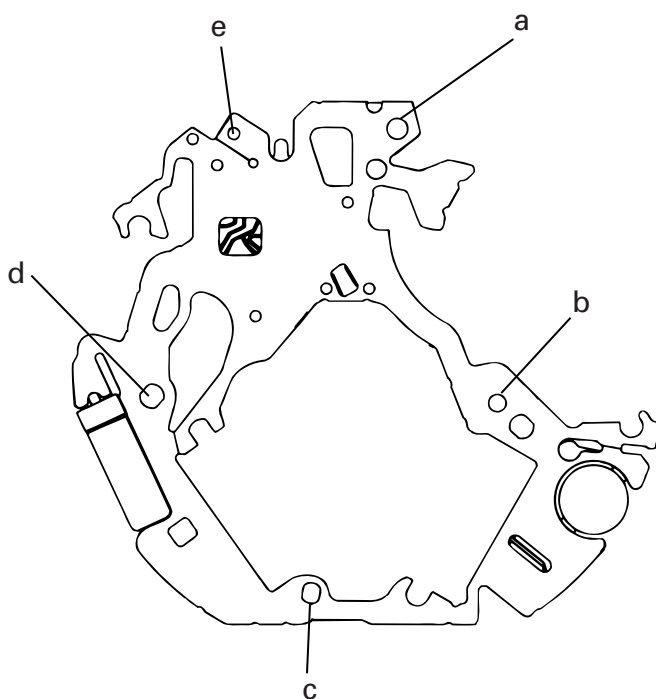

⑱ Pin for train wheel bridge

• **How to remove**



Turn the pin 90-degree counterclockwise with a screwdriver to loosen the pin.

• **How to install**

Set the pin in the direction as shown below. Then, turn it 90-degree clockwise with a screwdriver to fix the pin.

• **Lubricating**

After installing the pin, lubricate the upper pivot of the parts as indicated in the table below.

	Moebius A 	Moebius F 
CAL. 7T62A	Minute wheel Small second wheel Minute counting wheel Center wheel for alarm Second counting wheel	Chronograph rotor for second Chronograph rotor for minute Alarm rotor Step rotor
CAL. 7T92A	Minute wheel Small second wheel Second counting wheel (1/20) Second counting wheel	Chronograph rotor for second (1/20) Chronograph rotor for second Chronograph rotor for minute Step rotor
CAL. 7T94A	Minute wheel Small second wheel Minute counting wheel	Chronograph rotor for second Chronograph rotor for minute Step rotor

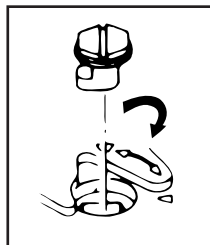

Pin for train wheel bridge

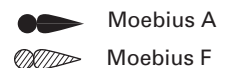
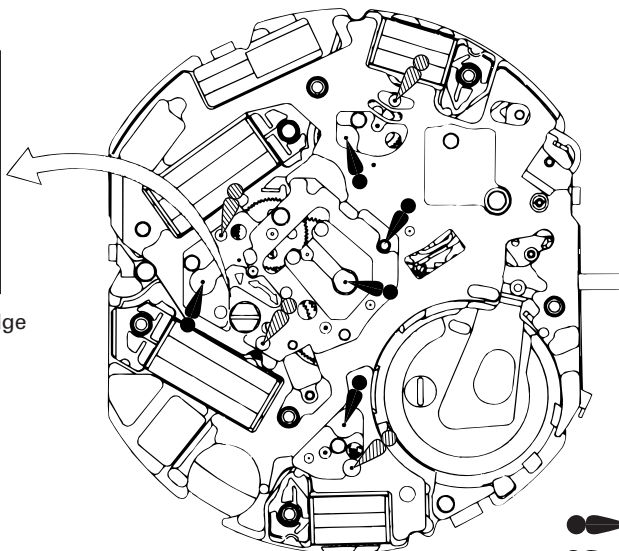

⑲ Train wheel bridge

• **How to install**

Before installing the train wheel bridge, carefully check the setting positions of the wheels and rotors. Be sure to check that each rotor has a lower pivot attached securely.

If the wheels and rotors are all set in position with the winding stem with crown at the first click, the train wheel bridge can be installed smoothly. There is no need to press down the train wheel bridge.

If the train wheel bridge will not be seated in position smoothly, the other parts must be set in the wrong position. Check their setting positions.

● Wheels and pinions

Notes:

1.

CAL. 7T62A:

Intermediate minute counting wheel and intermediate alarm wheel can be used interchangeably.

CAL. 7T92A:

Intermediate wheel for second counting (1/20) and intermediate minute counting wheel can be used interchangeably.

2. The following rotors for each caliber can be used interchangeably:

CAL. 7T62A

- Chronograph rotor for second (1/5)
- Chronograph rotor for minute
- Alarm rotor
- Step rotor

CAL. 7T92A

- Chronograph rotor for second (1/20)
- Chronograph rotor for second
- Chronograph rotor for minute
- Step rotor

CAL. 7T94A

- Chronograph rotor for second (1/5)
- Chronograph rotor for minute
- Step rotor







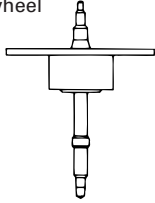
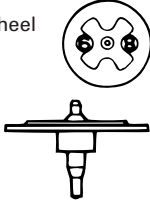

• Setting position

See the illustration on the next page.

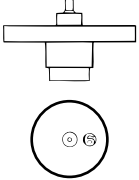
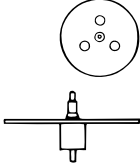
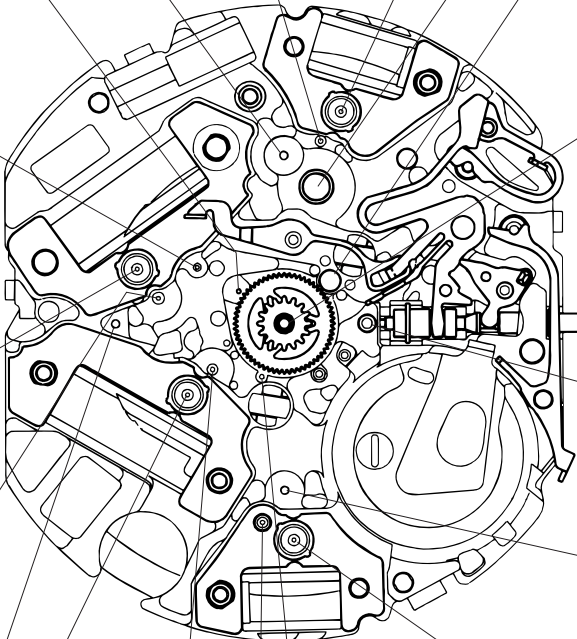
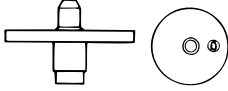
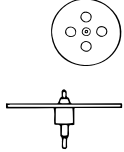
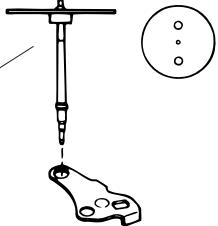
TECHNICAL GUIDE

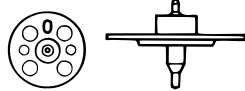
Cal. 7T62A/7T92A/7T94A

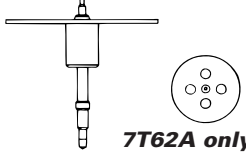
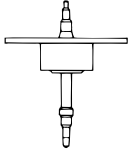

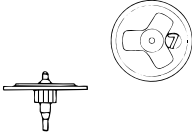
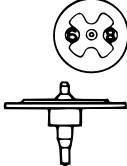
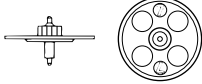



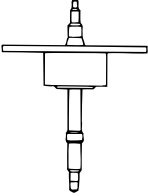
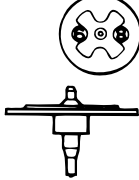

The illustrations refer only to Cal. 7T62A & 7T94A.

<p>③1 0270 582 <7T62A> Center wheel for alarm</p> <p>②1a 0240 582 <7T94A> Small second wheel</p> 	<p>③0 0950 590 <7T62A> Intermediate alarm wheel</p> <p>②1b 0950 590 <7T94A> Intermediate small second wheel</p> 	<p>③7 4146 710 Alarm rotor</p>  <p>7T62A only</p>	<p>③2 0261 582 Minute wheel for alarm</p>  <p>7T62A only</p>		
<p>②3 0231 580 Third wheel & pinion</p> 			<p>②7 0261 580 Minute wheel</p> 		
<p>②2 0241 583 Fourth wheel & pinion</p> 			<p>②0 0888 582 Second counting wheel</p> 		
<p>③8 4146 710 Step rotor</p> 			<p>④7 4283 581 Spacer for center wheel & pinion</p> 		
<p>②4 0701 580 Fifth wheel & pinion</p> 			<p>④4 0281 580 Setting wheel</p> 		
<p>②1 0240 580 Small second wheel</p>  <p>7T62A only</p>			<p>②9 0902 580 Minute counting wheel</p> 		
<p>②5 0885 590 First intermediate wheel for second counting</p> 			<p>③9 4146 710 Chronograph rotor for second</p> 	<p>②8 0950 590 Intermediate minute counting wheel</p> 	<p>②6 0885 591 Second intermediate wheel for second counting</p> 

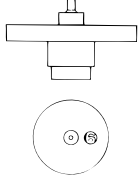
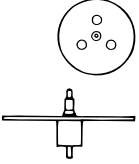
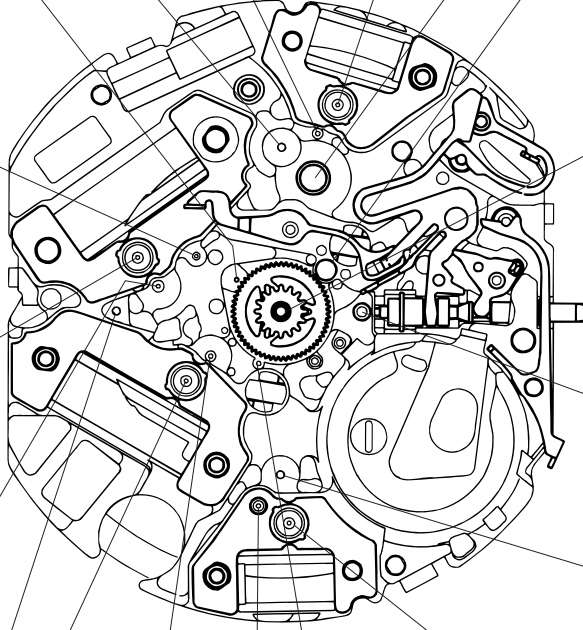
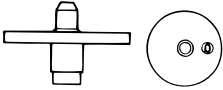
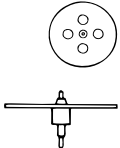
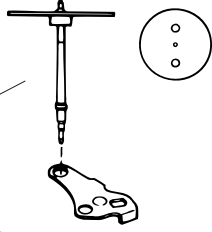
TECHNICAL GUIDE

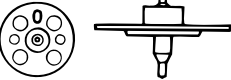
Cal. 7T62A/7T92A/7T94A

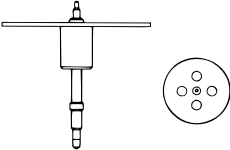
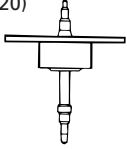
The illustrations refer only to Cal. 7T92A.

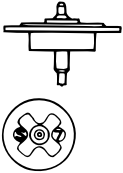
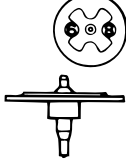
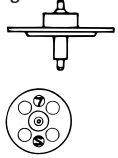
<p>③① 0270 582 Minute counting wheel</p> 	<p>③⑩ 0950 590 Intermediate minute counting wheel</p> 	<p>③⑦ 4146 710 Chronograph rotor for minute</p> 	<p>③② 0261 582 Intermediate wheel for hour counting</p> 		
<p>②③ 0231 580 Third wheel & pinion</p> 			<p>②⑦ 0261 580 Minute wheel</p> 		
<p>②② 0241 583 Fourth wheel & pinion</p> 			<p>②⑩ 0888 582 Second counting wheel</p> 		
<p>③⑧ 4146 710 Step rotor</p> 			<p>④⑦ 4283 581 Spacer for center wheel & pinion</p> 		
<p>②④ 0701 580 Fifth wheel & pinion</p> 			<p>④④ 0281 580 Setting wheel</p> 		
<p>②① 0240 580 Small second wheel</p> 			<p>②⑨ 0902 580 Second counting wheel (1/20)</p> 		
<p>②⑤ 0885 594 First intermediate wheel for second counting</p> 			<p>③⑨ 4146 710 Chronograph rotor for second</p> 	<p>②⑧ 0950 590 Intermediate wheel for second counting (1/20)</p> 	<p>②⑥ 0885 595 Second intermediate wheel for second counting</p> 

- ④1 Switch lever (A)
- ④2 Setting lever
- ④3 Yoke
- ④9 Train wheel setting lever

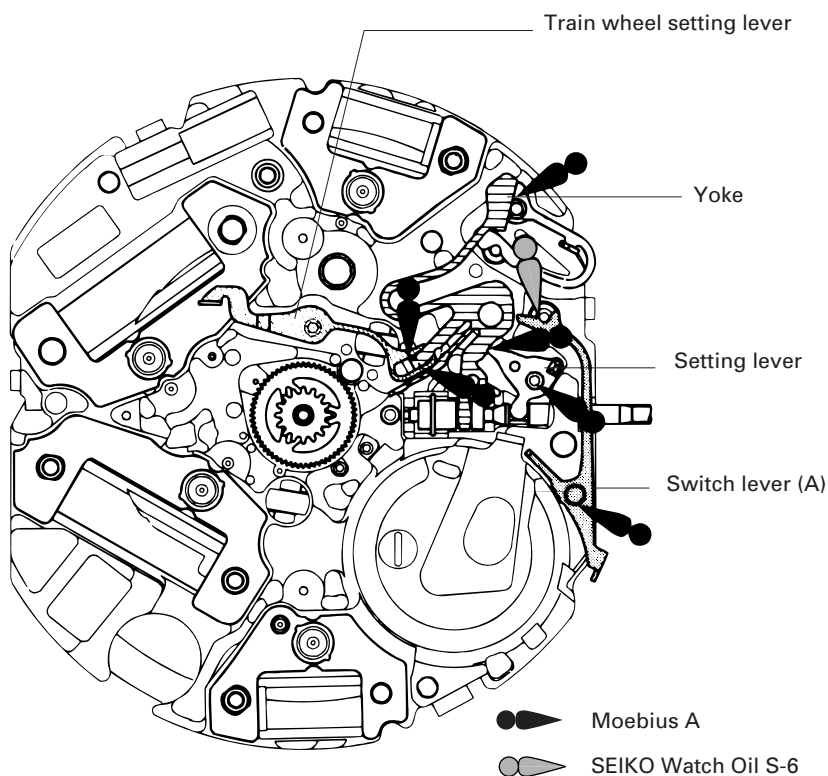

• **Setting position and lubricating**

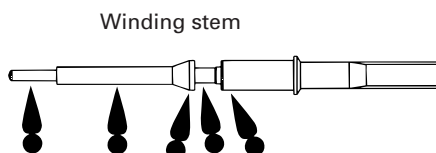

- ④8 Center wheel and pinion

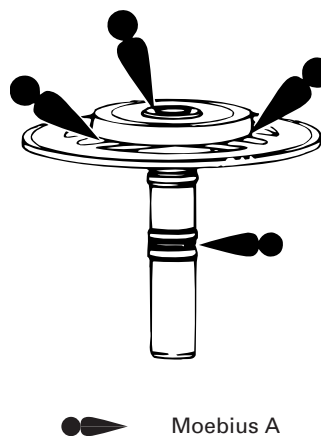

• **Lubricating**

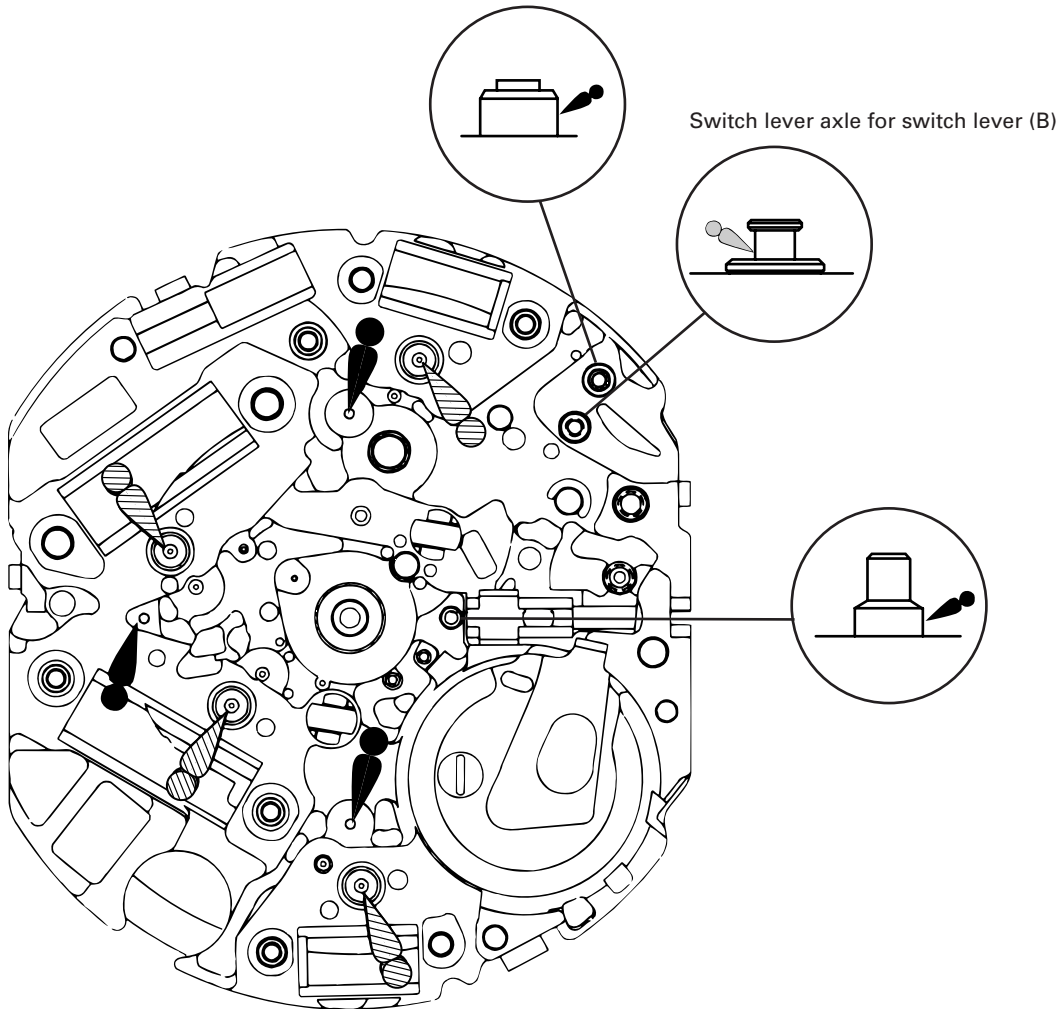

55 Main plate

• Lubricating



-  Moebius A
-  Moebius F
-  SEIKO Watch Oil S-6

IV. VALUE CHECKING

● Coil block resistance

Coil block (A)	1.70 K Ω ~ 2.60 K Ω
Coil block for chronograph second	1.70 K Ω ~ 2.60 K Ω
Coil block for chronograph minute (Cal. 7T62A) Coil block for second counting (1/20) (Cal. 7T92A)	1.80 K Ω ~ 2.40 K Ω
Coil block for alarm (Cal. 7T62A) Coil block for chronograph (Cal. 7T92A)	1.80 K Ω ~ 2.40 K Ω

● Upconverter coil resistance : 150 Ω ~ 180 Ω

● Current consumption

For the whole movement	Less than 1.10 μ A (with 1.55 V supplied from a battery) (when the stopwatch is not used)
For the circuit block alone	Less than 0.20 μ A (with 1.55 V supplied from a battery)

When measuring the current consumption with SEIKO Multi-Tester S-860, select the measurement range as follows:

For the whole movement	Use the range of 40 μ A of SUPPLY V (= 1.55 V) & GATE TIME (2 S)
For the circuit block alone	Use the range of 4 μ A of SUPPLY V (= 1.55 V) & GATE TIME (2 S)

V. FUNCTION CHECKING

● TIME SETTING AND STOPWATCH HAND POSITION ADJUSTMENT

Follow the procedure in "II. NECESSARY PROCEDURE AFTER BATTERY CHANGE" to set the time hands and reset the stopwatch hands to the "0" position.

● STOPWATCH FUNCTION

- * Before checking the stopwatch function, reset the stopwatch hands to the "0" position following the procedure in "II. NECESSARY PROCEDURE AFTER BATTERY CHANGE."
- * Check that the crown is at the normal position. Otherwise, the stopwatch operation cannot be made.

1. Checking for Standard Measurement / Accumulated Elapsed Time Measurement

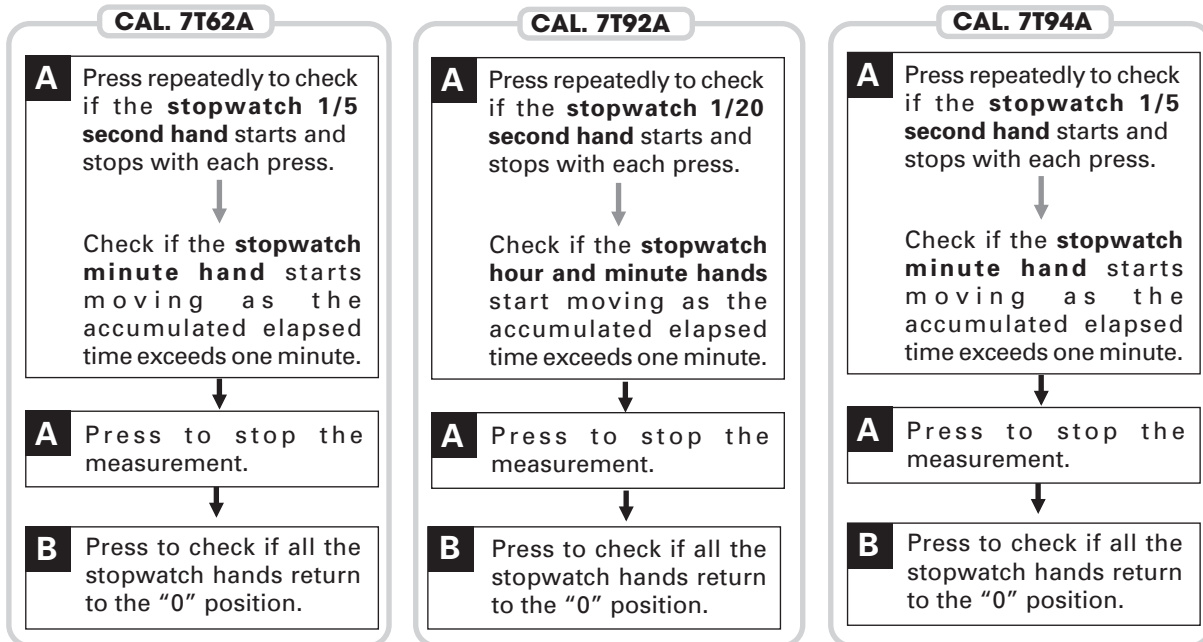

2. Checking for Split Time Measurement

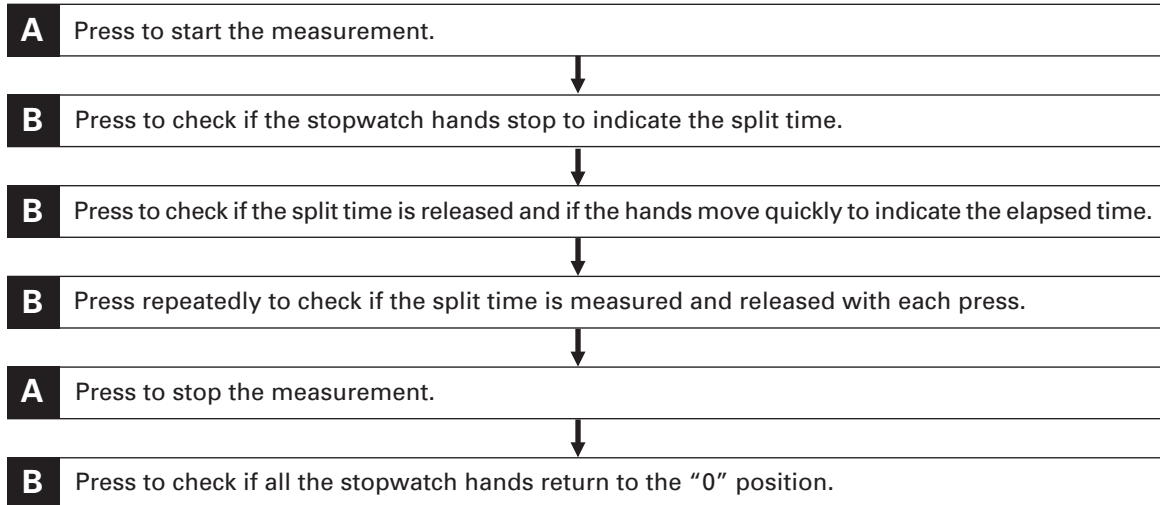

Note for the stopwatch 1/20 second hand for Cal. 7T92A:

* After the stopwatch is started, the stopwatch 1/20-second hand automatically stops and stays at the "0" position if the measurement exceeds 10 minutes. When the measurement is stopped or split time is measured, it moves to indicate the elapsed 1/20 seconds.

Also, after the stopwatch is restarted or split time is released, the stopwatch 1/20-second hand automatically stops and stays at the "0" position if the measurement exceeds 10 minutes.

● **ALARM FUNCTION (Only for Cal. 7T62A)**

- Before checking the alarm function, set the time and alarm hands to the current time following the procedure in "II. NECESSARY PROCEDURE AFTER BATTERY CHANGE."

1. Alarm Time Setting

CROWN Pull out to the 1st click.



B Press repeatedly to set the alarm hands.
* With each press, they move one minute. They move quickly if the button is kept pressed. They stop as they reach the current time. Release and press the button, and the hands will start moving again.



2. Alarm Engagement

CROWN Crown Push back in to the normal position.
* At the designated alarm time the alarm rings for 20 seconds and stops. To stop it manually, press button "A" or "B."
* After the alarm rings, the alarm minute hand starts moving at one-minute intervals as the alarm hands indicate the current time.



3. To Cancel or Readjust the Designated Alarm Time

CROWN Pull out to the 1st click.



B To cancel: Press repeatedly to set the alarm hands to the desired alarm time.
To readjust: Press repeatedly to set the alarm hands to the desired alarm time.



CROWN Push back in to the normal position.

VI. TROUBLESHOOTING

	Symptom	Possible causes	Solutions
Movement	The watch stops operating.	The battery has been depleted.	Measure the battery voltage. Replace the battery with a new one if necessary.
		The hour wheel and the pinion of the minute wheel are not properly engaged. (Or the teeth of the hour wheel and/or minute wheel has been broken.)	Check the relevant parts, and replace the damaged parts with new ones.
		The hooking portions of the circuit block cover are not properly engaged, resulting in poor conductivity.	Securely attach the hooks of the circuit block cover to the main plate.
		The coil has been burned out.	Measure the coil block resistance. Replace the coil with new one if necessary.
		Any of the wheels has been contaminated with dirt, dust or other particles. An excessive amount of oil in the movement caused adhesive forces among the parts. (wringing)	Remove dirt or dust and clean the contaminated wheels. Be careful so as not to damage the teeth of the plastic parts while cleaning.
	The current consumption for the whole movement exceeds the standard value.	Dirt, dust or foreign particles are adhered to the movement.	Remove dirt, dust or foreign particles and clean the movement.
		The driving pulse is generated in order to compensate the excessive load applied to the wheels. (The oil is deteriorated, leaked or ran out.)	If the current consumption for the circuit block alone is within the standard value range, overhaul and clean the movement parts, and then make the measurement again.
	The current consumption for the circuit block alone exceeds the standard value.	The light from outside the movement is affecting the measurement.	Shut out the light, and make the measurement again.
		There is a defect in the IC (integral circuit).	Replace the circuit block with a new one.
		The date dial shows an abnormal movement.	Check the rotation of the date dial. Bend the date dial downward to adjust the clearance. Or replace the date dial with a new one.
The date dial does not move.			
The date does not change.			
Stopwatch/ Alarm	Any of the hands of the stopwatch or alarm has stopped moving or shows an abnormal movement.	The relevant coil has been burned out.	Measure the coil block resistance. Replace the coil with new one if necessary.
		The excessive load is being applied to the chronograph wheels due to dust or foreign particles adhered to them or oil starvation.	Clean the relevant parts and lubricate with an adequate amount of oil.

	Symptom	Possible causes	Solutions
	Step motor shows an abnormal movement.	There is a crack on the circuit block switch pattern.	Replace the circuit block with a new one.
		The step motor has been deformed.	Replace the stator with a new one.
	The buttons do not operate normally.	The amount of oil around the buttons is insufficient.	Clean the buttons and lubricate appropriately.
		The circuit block pattern has been broken or bended.	Adjust the circuit block pattern or replace the circuit block with a new one.
	The alarm does not sound. (For 7T62A only)	The Piezoelectric element has been broken or out of alignment.	Replace the piezoelectric element with a new one.
		The upconverter coil is broken.	Replace the circuit block with a new one.
	The alarm sound is too small. (For 7T62A only)	The Piezoelectric element is not securely installed.	Remount the piezoelectric element with a new one.
Exterior parts	The crown falls off.	The winding stem is not securely installed. (The setting lever and yoke are disengaged.)	Check the main plate, winding stem, setting lever and yoke. Replace the defective parts with new ones.
	The current consumption exceeds the standard value.	The excessive load is being applied due to frictions among the hour, minute and chronograph hands.	Adjust or remount the relevant hands.
	Small amount of water/blur on the dial glass persists.	Water resistance is deteriorated. The watch has been subjected to water pressure that exceeds the guaranteed degree.	Investigate the causes. Check, adjust and clean inside of the watch.